

DAFTAR PUSTAKA

- Afiah, N. N. dan Rahmatika, D. N. 2014. Factors Influencing The Quality of Financial Reporting and Its Implications on Good Government Governance (Research on Local Government Indonesia). *International Journal of Business, Economics and Law*, 5(1), pp 111–121.
- Ajzen, Icek. 1991. *The Theory of Planned Behavior. Organizational Behavior and Human Decision Processes*. 50, pp 179-211. Penerbit Academic Press. Inc
- Al-Zwyalif, I. M. 2015. The Role of Internal Control in Enhancing Corporate Governance: Evidence from Jordan. *International Journal of Business and Management*, 10(7), pp 57–66.
- Aramide, S. F., Mustapha, dan Bashir, M. 2015. The Effectiveness of Internal Control System and Financial Accountability at Local Government Level in Nigeria. *International Journal of Research in Business Management*, 3(8), pp 1-6.
- Ashbaugh-Skaife, H., Collins, D. W., dan Kinney, W. R. 2007. The Discovery and Reporting of Internal Control Deficiencies Prior to SOX-Mandated Audits. *Journal of Accounting and Economics*, 44(1–2), pp 166–192.
- Astrina, F. 2016. Pengaruh Budaya Organisasi, Komitmen Organisasi dan Penerapan Prinsip-Prinsip Good Corporate Governance GCG terhadap Kinerja Perguruan Tinggi dengan Pendekatan Balanced Scorecard (BSC). *Jurnal Ilmiah Ekonomi Global Masa Kini*, 7(1), pp 61–78.
- Baron dan Kenny. 1986. The Moderator-Mediator Variable Distinction in Social Psychological Research: Conceptual, Strategic, and Statistical Considerations. *Journal of Personality and Social Psychology*, 51(6), pp 1173-1182.
- Bashir, M., Jianqiao, L., Abrar, M., dan Ghazanfar, F. 2012. The Organization's Cultural Values: A Study of Public Sector Universities in Pakistan. *African Journal of Business Management*, 6(10), pp 3686–3693.
- Berry, A. J., Broadbent, J., dan David Otley. 1995. *Management Control: Theories, Issues and Practices*. London: Macmillan Press Ltd.
- Berry, A. J., Coad, A. F., Harris, E. P., Otley, D. T., dan Stringer, C. 2009. Emerging Themes in Management Control: A review of Recent Literature. *British Accounting Review*, 41(1), pp 2–20.
- Birnberg, Jacob G., Luft, Joan., dan Shields, Michael D. 2006. Psychology Theory in Management Accounting Research. *Handbook of Management Accounting Research*, 1. pp 115-137.
- Bosetti, L. 2009. Corporate Governance and Internal Control: Evidence from Local Public Utilities. *2nd European Risk Conference: Risk and Governance*, pp 1–37.



Bois, Cindy Du., Jegers, Marc., Gieter, Sara De., Schepers, Catherine.,
ans, Roland. 2006. Principal-Agent Relationships on the Stewardship-
Axis. *Nonprofit Management and Leadership* 17(1), pp 25–47.

ag, Sunhwa Choi, Chris E. Hogan, dan Joonil Lee. 2013. The Effect of
Resource Investment in Internal Control on The Disclosure of Internal
Weaknesses. *Auditing: A Journal of Practice & Theory* 32(4), pp 169–99.

Fong. 1986. Radical Developments in Accounting Thought, *The*

accounting review 61 (4), pp 601-632.

Clarke, T. dan Branson, D. 2014. *The SAGE Handbook of Corporate Governance*. London: SAGE Publications Ltd.

Cribb, J. 2006. Agents or Stewards? Contracting with. *Policy Quarterly*, 2(2), pp 11-17.

Darwanis dan Mahyani, D. D. 2009. Pengaruh Kapasitas Sumber Daya Manusia, Pemanfaatan Tehnologi Informasi dan Pengendalian Intern Akuntansi terhadap Keterandalan Pelaporan Keuangan Pemerintah Daerah. *Jurnal Telaah dan Riset Akuntansi*, 2(2), pp 133–151.

Davis, J. H., Schoorman, F. Davi., dan Donaldson, Lex. 1997. Towards a Stewardship Ttheory of Management. *Academy of Management Review*, 22(1), pp 20–47.

Denison, D. R., Haaland, S., Goelzer, P., Denison, D. R., Haaland, S., dan Goelzer, P. 2003. Advances in Global Leadership Corporate Culture and Organizational Effectiveness: Is There A Similar Pattern Around The World? *Advances in Global Leadership, March*, pp 205–227.

Denison, Daniel R.Mishra, A. K. 1995. Toward a Theory of Organizational Culture and Effectiveness. *Organization Science.*, 6(2), pp 204–223. 20p. 3 Diagrams.

Dineshkumar, Sabina dan Priya Kogulacumar. 2011. Internal Control System and Its Impact on The Performance of the Sri Lanka Telecom Limited in Jaffna District. *International Journal of Advance Computer Technology* 2(6), pp 56–64.

Donaldson, L. 1996. *For Positivist Organization Theory*. London: SAGE Publication.

Donaldson, L. dan Davis, J. H. 1991. Stewardship Theory or Agency Theory: CEO Governance and Shareholder Returns. *Australian Journal of Management*, 16 June 1991, pp 49–66.

Doyle, J., Ge, W., dan Mcvay, S. 2007. Determinants of Weaknesses in Internal Control Over Financial Reporting. *Jurnal of Accounting dan Economics*, 44, pp 193–223.

Duke II, J. dan Edet, G. H. 2012. Organizational Culture as A Determinant of Non-governmental Organization Performance: Primer Evidence from Nigeria. *International Business and Management*, 4(1), pp 66–75.

Dzomira, S. 2014. Internal Controls and Fraud Schemes in Not-for-profit Organisations : A Guide for Good Practice. *Research Journal of Finance and Accounting*, 5(2), pp 118–126.

Effendi, A. 2009. *The Effects of The Regional Functional Supervision and The Internal Control on The Good Governance Application and Its Impact on The Department Performance*. Bandung: Universitas Pajajaran.



Korupsi di Perguruan Tinggi. (<https://antikorupsi.org/news/korupsi-di-tan-tinggi>, diakses 11 November 2017).

C. M. 1989. Agency Theory: An Assessment and Review. *The Academy gement Review*, 14(1), pp 57–74.

Optimization Software:
www.balesio.com

A. 2009. Quality of Internal Control Over Financial Reporting, Corporate nce and Credit Ratings. *International Journal of Disclosure and*

Governance, 6 November 2008, pp 127–149.

Eysink, W. dan Paape, L. 2016. *Good Governance Driving Corporate Performance? A Meta-analysis of Academic Research dan Invitation to Engage in The Dialogue*. Netherland: Deloitte.

Fadilah, S. 2013. The Influence of Good Governance Implementation to Organization Performance: Study on Institution Amil Zakat Indonesia. *International Journal of Social Sciences*, 7(1), pp 15–33.

Faerman, L. B. 2009. *The Relationship between Organizational Culture and Effectiveness in University Residence Hall Associations: A Competing Values Study*. Disertasi. Florida: Florida Atlantic University.

Fekete, H. dan Bocskei, E. 2011. Cultural Waves in Company Performance. *Research Journal of Economics, Business and ICT*, 3, pp 38–42.

Feng, M., Li, C., dan McVay, S. 2009. Internal Control and Management Guidance. *Journal of Accounting and Economics*, 48(2–3), pp 190–209.

Fox, M. dan Hamilton, Robert T. 1994. Ownership and Diversification: Agency Theory or Stewardship Theory. *Journal of Management Studies*, 31(1), pp 69–81.

Fu, Weihui dan Satish P. Deshpande. 2014. The Impact of Caring Climate, Job Satisfaction, and Organizational Commitment on Job Performance of Employees in a China's Insurance Company. *Journal of Business Ethics* 124(2), pp 339–49.

Gina, O., Adeghe, R., dan Kingsley, O. O. 2014. Internal Control as A Potential Instrument for Corporate Governance. *IOSR Journal of Economics and Finance IOSR-JEF*, 26, pp 66–70.

Ginting, S. 2013. *Characteristic Organizational Culture on The Department of The Education Youth and Sports at Cimahi City*. Disertasi. Bandung: Universitas Padjadjaran.

Glaser, S. R., Zamanou, S., dan Hacker, K. 1987. Measuring and Interpreting Organizational Culture. *Management Communication Quarterly*, 1(2), pp 173–198.

Gudono. 2016. *Analisis Data Multivariat*. Yogyakarta: Badan Penerbit Fakultas Ekonomi UGM.

Gozali, I. 2008. *Model Persamaan Stuktural: Konsep Aplikasi dengan Program Amos 16.0 SPSS*. Semarang: Badan Penerbit Universitas Diponegoro.

Hair, J. F., Black, W. C., Babin, B.J., dan Anderson, R. E. 2010. *Multivariate Data Analysis 7th ed*. New Jersey: Person Prentice Hall.

Haliah. 2013. *Kualitas Infomasi Laporan Keuangan Pemerintah Daerah dan Faktor yang Mempengaruhinya*. Disertasi. Makassar: Universitas Hasanuddin.



Quality of Report, is there A Management, and Information Technology Empirical Evidence from West Sulawesi Province, Indonesia. *International of Economic Research (IJER)*, 12(1), pp 177–193.

u, P., Chao, M., dan Wright, P. M. 2006. The HR Competencies-HR Business Link: A studi in Taiwanese High-Tech Companies. *Human Resource Management*, 45(3), pp 391–406.

- Harris, L. C. dan Ogbonna, E. 2002. The Unintended Consequences of Culture Interventions: A Study of Unexpected Outcomes. *British Journal of Management*, 13(1), pp 31–49.
- Henri, J. F. 2006. Organizational Culture and Performance Measurement Systems. *Accounting, Organizations and Society*, (31)1, pp 77–103.
- Hernandez, M. 2008. Promoting Stewardship Behavior in Organizations: A Leadership Model. *Journal of Business Ethics*, (80)1, pp 121–128.
- Hernandez, M. 2012. Toward an Understanding of The Psychology of Stewardship. *Academy of Management Review*, (37)2, pp 172–193.
- Hoesada, J. 2002. Akuntansi-Organisasi-Nirlaba. Seminar *Transparency International Indonesia*. Jakarta.
- Hoffmann, T. 1999. The Meanings of Competency. *Journal of European Industrial Training*, 236, pp 275–286.
- Hofstede, G. 2001. Cultures and Organizations: Software of The Mind. *Journal of International Business Studies*, 23(2), pp 362–365.
- Hofstede, G. 2011. Dimensionalizing Cultures: The Hofstede Model in Context. *Online Readings in Psychology and Culture*, 2(1), pp 1–26.
- Hofstede, G., Neuijen, B., Daval Ohayv, D., dan Sanders, G. 1990. Measuring Organizational Cultures; A Qualitative and Quantitative Study Across Twenty Cases. *Administrative Science Quarterly*, 35(2), pp 286–316.
- Hoitash, U., Hoitash, R., dan Bedard, J. C. 2009. Corporate Governance and Internal Control Over Financial Reporting: A Comparison of Regulatory Regimes. *Accounting Review*, 84(3), pp 839–867.
- Hooghiemstra, R., Hermes, N., dan Emanuels, J. 2015. National Culture and Internal Control Disclosures: A Cross-country Analysis. *Corporate Governance Oxford*, 234, pp 357–377.
- Ibrahim, Sahabi, Gordon Diibuzie, dan Mohammed Abubakari. 2017. The Impact of Internal Control Systems on Financial Performance: The Case of Health Institutions in Upper West Region of Ghana. *International Journal of Academic Research in Business and Social Sciences* 7(4), pp 684–696.
- Indriasih, D. 2014. The Effect of Government Apparatus Competence and The Effectiveness of Government Internal Control Toward The Quality of Financial Reporting in Local Government. *Research Journal of Finance and Accounting*, 520, pp 38–47.
- Inskpetorat Jendral, Kementrian Riset Teknologi dan Pendidikan Tinggi. 2016. *Laporan Hasil Pemeriksaan Badan Pemeriksa Keuangan RI atas Laporan Keuangan Tahun 2016*. Jakarta: Kementrian Riset Teknologi dan Pendidikan



dan Meckling, W. H. 1976. Theory of The Firm: Managerial Behavior, Costs and Ownership Structure. *Journal of Financial Economics*, 3(4), pp 305–360.

Li, C., dan Rupley, K. H. 2011. Changes in Corporate Governance Related with The Revelation of Internal Control Material Weaknesses and Subsequent Remediation. *Contemporary Accounting Research*, 28(1), pp

331–383.

Kaifi, Belal A., Noori, Selaiman A. 2010. Organizational Mangement: A Study on Middle Managers, Gender, and Emotional Intelligence Levels. *Journal of Business Studies Quarterly*, 1 (3), pp 13-23.

Kaifi, Belal A., Noori, Selaiman A. 2011. Organizational Behavior: A Study on Managers, Employees, and Teams. *Journal of Management Policy and Practice*, 12(1)

Kalumata, Merlyn C. T., Ventje Ilat, dan Jessy D. L. Warongan. 2016. Pengaruh Kompetensi Sumber Daya Manusia, Teknologi Informasi, Reviu Laporan Keuangan Dan Sistem Pengendalian Internal Terhadap Kualitas Laporan Keuangan Pada Pemerintah Provinsi Sulawesi Utara. *Jurnal Accountability* 5(2), pp 152–67.

Kementerian Pendayagunaan Aparatur Negara dan Reformasi Birokrasi. 2010. Perpres No 81 Tahun 2010 *Grand Design Reformasi Birokrasi*. Jakarta: Kementerian Pendayagunaan Aparatur Negara dan Reformasi Birokrasi.

Kinicki, A., Kreitner, R., Cole, N., Digby, V., dan Koziol, N. 2010. *Organizational Behaviour, Third CDN Edition. McGraw-Hill Ryerson Higher Education 2010*.

Konzelmann, S. J., Conway, N., Wilkinson, F., dan Trenberth, L. 2006. Corporate Governance and Human Resource Management. *British Journal of Industrial Relations*, (44)September, pp 541–567.

Kooiman, J. 1994. *Modern Governance*. London: SAGE Publication.

Kooiman, J. 2003. *Governing as Governance*. London: SAGE Publication.

Kreitner, Robert. dan Kinicki, Angelo. 2014. *Perilaku Organisasi* Edisi 9. Jakarta: Penerbit Salemba Empat.

Lagat, Cornelius Kipkembol, Caroline Ayuma Okelo, dan Edwin Terer. 2016. Effect of Internal Control Systems on Financial Management in Baringo County Government, Kenya. *Journal of Economics Finance and Accounting* 3(1), pp 1–16.

Lakis, V. dan Giriunas, L. 2012. The Concept of Internal Control System: Theoretical Aspect. *Ekonomika* 2012, 91(2), pp 142-152.

LAN. 2000. *Akuntabilitas dan Good Governance*. Jakarta: Penerbit LAN.

Limbulan, S. dan Tarigan, J. 2016. Budaya Organisasi terhadap Kinerja Keuangan dengan menggunakan Perilaku Pemilik atas Isu Manajemen Lingkungan sebagai Variabel Intervening. *Business Accounting Review*, 4(1), pp 157–168.

Luthans, F. 2011. *Organizational Behavior Organizational Behavior Edisi 12*. New York: McGraw-Hill Companies, Inc.



Optimization Software:
www.balesio.com

2009. *Akuntansi Sektor Publik*. Yogyakarta: Penerbit ANDI.

dan Kibati, P. 2016. Influence of Internal Control Systems on Financial Performance of Kenya Farmers' Association Limited. *International Journal of Economics, Commerce and Management United Kingdom*, IV(4), pp 783–800.

2003. *Using Competencies to Identify High Performers: An Overview of Statistics*. Philadelphia, USA: Hay Group.

- Meyer, J. P. dan Allen, N. J. 1991. A Three Component Model Conceptualization of Organizational Commitment. *Human Resource Management Review*, 1(1), pp 61–89.
- Meyer, J. P. dan Lynne Herscovitch. 2001. Commitment in the Workplace: Toward a General Model. *Human Resource Management Review* 11(3), pp 299–326.
- Michelon, G., Beretta, S., dan Bozzolan, S. 2009. *Disclosure on Internal Control Systems as a Substitute of Alternative Governance Mechanisms*, February 2009, pp 1–40.
- Mihaela, D. dan Iulian, S. 2012. Internal Control and The Impact on Corporate Governance, in Romanian Listed Companies. *Journal of Eastern Europe Research in Business dan Economics*, pp 1–10.
- Moeller, R. R. 2009. *Brink's Modern Internal Auditing 7 Th Edition*. USA: John Wiley dan Sons, Inc.
- Momot, V. E. dan Litvinenko, O. M. 2012. Relationship between Corporate Culture and Effectiveness of an Organization. *Zeszyty Naukowe Wyższej Szkoły Zarządzania Ochroną Pracy W Katowicach Nr 18/2012, S. 5-20*, 1(1), pp 5–20.
- Murhaban. 2010. *The Influence of Internal Control, Internal Audit and Organizational Commitment to Good Government Governance and It's Implication to Local Governance Performance*. Disertasi. Bandung: Universitas Pajajaran.
- Muth, M. M. dan Donaldson, L. 1998. Stewardship Theory and Board Structure: a Contingency Approach. *Corporate Governance: An International Review*, 6(1), pp 5–28.
- Nadirsyah. 2008. Pengaruh Hasil Audit Ekstern dan Komitmen Manajemen terhadap Keefektifan Pengendalian Intern dan Kinerja Keuangan Perusahaan. *Jurnal MAKSI* 81, pp 59-73.
- Napitupulu, I. H. 2015. Impact of Organizational Culture on The Quality of Management Accounting Information System : A Theoretical Approach. *IISTE*, 6(4), pp 74–84.
- Naz'aina. 2015. The Effect of Internal Control System and Amil Competence on The Financial Reporting Quality at Zakat Management Institution Active Member of Zakat Forum in Special Capital City Region Jakarta and West Java Provinces. *Procedia - Social and Behavioral Sciences*, 211, pp 753–760.
- Njanike, K., Mutengezanwa, M., dan Gombarume, F. B. 2011. Internal Controls in Ensuring Good Corporate Governance in Financial Institutions. *Annals of the University of Petroşani Economics*, 11(1), pp 187–196.
- Nuryanto, M. dan Afiah, N. N. 2013. The Impact of Apparatus Competence, Information Technology Utilization and Internal Control on Financial Statement Quality Study on Local Government of Jakarta Province - Indonesia. *World of Business Research*, 3(4), pp 157–171.
10. Organisational Culture and Corporate Performance: Empirical e from Nigeria. *Journal of Business Systems, Governance and Ethics*, 1–12.
- n, K.Praveen Parboteeah, dan Shim, Wonshul. 2007. The Relationship n Perceived Compensation, Organizational Commitment and Job tion: The Case of Mexican Workers in The Korean Maquiladoras.



International Journal of Human Resource Management 18(10), pp 1768–1781.

Palmer, Kristine N., Douglas E. Ziegenfuss, dan Robert E. Pinsker. 2004. International Knowledge, Skills, and Abilities of Auditors/accountants. *Managerial Auditing Journal* 19(7), pp 889–896.

Pangewa, M. 2015. The Influence of The Organizational Culture Toward The Performance of Local Governance. *Mediterranean Journal of Social Sciences*, 6(6), pp 307–314.

PDDIKTI. 2017. *Pangkalan Data Pendidikan Tinggi* (ONLINE) (<https://forlap.ristekdikti.go.id>, diakses 1 Oktober 2017).

Perka-BKN-N0-7-Tahun. 2013. *Pedoman Penyusunan Standar Kompetensi Manajerial Pegawai Negeri Sipil*. Jakarta: Badan Kepegawaian Negara.

Peraturan Pemerintah No. 60. 2008. *Sistem Pengendalian Intern Pemerintah*. Jakarta: Presiden Republik Indonesia.

Petrovits, C., Shakespeare, C., dan Shih, A. 2011. The causes and Consequences of Internal Control Problems in Nonprofit Organizations. *The Accounting Review*, 86(1), pp 325–357.

Pfister, J. 2009. *Managing Organizational Culture for Effective Internal Control*. Zurich: Physica-Verlag A Springer Company.

Pinho, C., Rodrigues, A. P., dan Dibb, S. 2014. The Role of Corporate Culture, Market Orientation and Organisational Commitment in Organisational Performance The Case of Non-profit Organisations. *Journal of Management Development*, 33(4), pp 374–398.

Podrug, N. 2011. The Strategic Role of Managerial Stewardship Behaviour for Achieving Corporate Citizenship. *Ekonomski Pregled*, 62(7–8), pp 404–420.

Pondeville, Sophie M. 2001. The Control Systems in The Environmental Management Framework. *January, Public Trust Conference, Ninth International Bangkok, Industry Network*, 1, pp 8–9.

Pratolo, S. 2008. Pengaruh Audit Manajemen, Komitmen Organisasional Manajer, Pengendalian Intern terhadap Penerapan Prinsip-Prinsip Good Corporate Governance dan Kinerja Badan Usaha Milik Negara di Indonesia. *Jurnal Akuntansi dan Investasi*, 9(1), pp 22–47.

Puspitarini, N. D. 2012. Peran Satuan Pengawasan Intern dalam Pencapaian Good University Governance pada Perguruan Tinggi Berstatus PK-BLU. *Accounting Analysis Journal*, 1(2), pp 1–8.

Rashid, M. Z. A., Sambasivan, M., dan Johari, J. 2003. The Influence of Corporate Culture and Organisational Commitment on Performance. *The Journal of Management Development*, 22(8), pp 708–728.

., Sri, F., dan Nurhayati. 2014. Pengaruh Budaya Organisasi dan Pengendalian Internal terhadap Good University Governance serta Implikasinya terhadap Kinerja Organisasi. *Prosiding Akuntansi*, 2, pp 125-132.

P. 2015. *Organizational Theory*. Prentice-Hall International.

P. dan Judge, T. 2013. *Organizational Behavior*. London: Pearson Education, Inc.



- Romney, M. B. dan Steinbart, P. J. 2015. *Accounting Information Systems*. London: Pearson Education, Inc.
- Rusnindita, K., Rosidi, dan Baridwan, Z. 2017. Determinan Kualitas Sistem Pengendalian Internal Pemerintah. *Journal of Research and Applications: Accounting and Management*, 2(2), pp 141–157.
- Sari, D. 2012a. Pengaruh Sistem Pengendalian Internal Pemerintah, Implementasi Standar Akuntansi Pemerintahan, Penyelesaian Temuan Audit terhadap Kualitas Laporan Keuangan Pemerintah Daerah dan Implikasinya Terhadap Penerapan Prinsip-prinsip Tata Kelola Pemerintahan yang B. *IJEB Indonesia Journal of Economics and Business*, pp 116–124.
- Sari, D. 2012b. *The Effect of Government Internal Control System, Implementasi of Government Accounting Standard, Completion of Audits Findings and The Quality of Local Government Financial Statement on The Good Governance Application*. Disertasi. Bandung: Universitas Pajajaran.
- Sekaran, Uma. dan Bougie, Roger. 2016. *Research Methods for Business 7th Edition*. West Sussex: John Wiley & Sons Ltd.
- Setiyawati, H. 2013. The effect of Internal Accountants' Competence, Managers' Commitment to Organizations and The Implementation of The Internal Control System on The Quality of Financial Reporting. *International Journal of Business and Management Invention*, 2(11), pp 19–27.
- Shahzad, F., Xiu, G., dan Shahbaz, M. 2017. Organizational Culture and Innovation Performance in Pakistan's Software Industry. *Technology in Society*, 51, pp 66–73.
- Shanmugam, Jaya Kumar, Mohd Hassan Che Haat, dan Azwadi Ali. 2012. The Impact of Internal Control on the Performance of Small and Medium Enterprise: Malaysian Evidence. *Conference on Interdisciplinary (JUNE)*, pp 1-12.
- Silviana dan Zahara, G. 2015. The Influence of Competence Local Government Agencies and The Implementation Government of Internal Control System Toward The Quality of Local Government Financial Statement. *Research Journal of Finance and Accounting Online*, 6(11), pp 138-148.
- Simon, Y., Mahfudnurnajamuddin, Mas'ud, M., dan Su'un, M. 2016. The Role of Apparatus Competence, Internal Control System on Good Governance and The Quality of Financial Statement Information. *Researchers World Journal of Arts, Science dan Commerce*, VII(4), pp 123–133.
- Suyono, E. dan Hariyanto, E. 2012. Relationship between Internal Control, Internal Audit, and Organization Commitment with Good Governance: Indonesian Case. *China-USA Business Review, ISSN 1537-1514 September 2012*, 11(9), pp 1237–1245.
- Syaiful H., Afnan Troena, E., & Setiawan, M. 2012. The Influence of Organizational Culture, Organizational Commitment to Job Satisfaction and Performance (Study at Municipal Waterworks of Jayapura, Papua). *International Journal of Business and Management Invention ISSN* 1(1), 69-76.
- Syaiful H., Afnan Troena, E., & Setiawan, M. 2010. The Correlation between Organizational Culture and Knowledge Management on Corporate Performance. *Journal of Knowledge Management*, pp 269–284.



- Uzkurt, C., Kumar, R., Semih Kimzan, H., dan Eminoğlu, G. 2013. Role of Innovation in The Relationship Between Organizational Culture and Firm Performance. *European Journal of Innovation Management*, 16(1), pp 92–117.
- Vallejo, M. C. 2009. The Effects of Commitment of Non-family Employees of Family Firms from The Perspective of Stewardship Theory. *Journal of Business Ethics*, 87(3), pp 379–390.
- Van Slyke, D. M. 2006. Agents or Stewards: Using Theory to Understand The Government-Nonprofit Social Service Contracting Relationship. *Journal of Public Administration Research and Theory*, 17(2), pp 157–187.
- Vlad, M. 2012. The Corporative Governance and Internal Audit. Case Study: Romanian Credit Institutions. *The USV Annals of Economics and Public Administration*, 12(2), pp 164–169.
- Volonté, C. 2015. Culture and Corporate Governance: The Influence of Language and Religion in Switzerland. *Management International Review*, 55(1), pp 77–118.
- Warongan, J. D. L., Pagalung, G., Uppun, P., dan Habbe, A. H. 2014. The Effects of Effectiveness Mediation of Internal Control System on Competency of Human Resources and Audit Opinion in Previous Year Toward Quality of Financial Statement. *Journal of Research in Business and Management*, 211, pp 9–16.
- Warongan, J. D. L., Pagalung, G., Uppun, P., dan Habbe, A. H. 2015. *Determinan Efektivitas Pengendalian Internal dan Pengaruhnya terhadap Kualitas Laporan Keuangan Pemerintah Daerah di Sulawesi Utara*. Disertasi. Makassar: Univeristas Hasanuddin
- West, Robert dan Charles Zech. 2006. Internal Financial Controls in the U.S. Catholic Church. *Louisville Institute*, pp 1–14.
- Weygandt, J., Kimmel, P., dan Kieso, D. 2014. *Financial Accounting*. Hoboken: John Wiley dan Sons, Inc.
- Widuri, R. dan Paramita, A. 2007. Analisis Hubungan Peranan Budaya Perusahaan terhadap Penerapan Good Corporate Governance pada PT Aneka Tambang Tbk. *Journal The WINNERS*, 8(2), pp 126–138.
- Wijatno, Serian. 2009. *Pengelolaan Perguruan Tinggi secara Efisien, Efektif, dan Ekonomis*. Jakarta: Penerbit Salemba Empat.
- Wiratno, Adi, Umi Pratiwi, dan Nurhikmah. 2013. Pengaruh Budaya Organisasi, Gaya Kepemimpinan, Komitmen Organisasi Dan Pengendalian Intern Terhadap Penerapan Good Governance Serta Implikasinya Pada Kinerja. *Proceeding Seminar Nasional & Call For Papers (SCA-3)*. Universitas Jenderal Soedirman. 1(1), pp 1–8.
- Yesil, S. dan Kaya, A. 2013. The Effect of Organizational Culture on Firm Financial Performance: Evidence from a Developing Country. *Procedia - Social and Behavioral Sciences*, 81, pp 428–437.
- Yilmaz, M. dan Ergun, E. 2008. Organizational Culture and Firm Effectiveness: An Examination of Relative Effects of Culture Traits and The Balanced Culture Analysis in an Emerging Economy. *Journal of World Business*, 43(3), pp 290–300.
- Yuliani, N. dan Suryandari, I. H. 2015. Internal Control and Risk Management in



Ensuring Good University Governance. *Journal of Education and Vocational Research*, 6(2), pp 6–12.

Zamzami, Faiz dan Ihda Arifin Faiz. 2015. Evaluasi Implementasi Sistem Pengendalian Internal: Studi Kasus Pada Sebuah Perguruan Tinggi Negeri. *Jurnal Akuntansi Multiparadigma* 6(1), pp 20–27.

Zelmiyanti, R. dan Anita, L. 2015. Pengaruh Budaya Organisasi dan Peran Auditor Internal terhadap Pencegahan Kecurangan dengan Pelaksanaan Sistem Pengendalian Internal sebagai Variabel Intervening. *Jurnal Politeknik Caltex Riau*, 8(10), pp 67–76.

Zhang, Yali, Xia Li, dan Feng Pan. 2009. The Relationship between Organizational Culture and Government Performance-Based on Denison Model. *Asian Social Science* 5(11), pp 131–37.

Zheng, W., Yang, B., dan McLean, G. N. 2010. Linking Organizational Culture, Structure, Strategy, and Organizational Effectiveness: Mediating Role of Knowledge Management. *Journal of Business Research*, 6(37), pp 763–771.

































































KUESIONER PENELITIAN DISERTASI



**PERAN PENGENDALIAN INTERNAL TERHADAP
GOOD GOVERNANCE PADA PERGURUAN
TINGGI NEGERI**

PROGRAM ILMU EKONOMI PASCASARJANA

UNIVERSITAS HASANUDDIN

MAKASSAR

2018



Optimization Software:
www.balesio.com

KUESIONER PENELITIAN DISERTASI

Peran Pengendalian Internal Terhadap *Good Governance* Pada Perguruan Tinggi Negeri.

Kepada Yth:

Bapak/Ibu/Sdr(i)....

Dengan hormat,

Sehubungan dengan penelitian yang saya lakukan mengenai persepsi orang mengenai peran pengendalian internal terhadap *good governance* pada perguruan tinggi negeri, dengan ini saya mohon kesediaan Bapak/Ibu/Sdr(i) untuk mengisi kuesioner terlampir.

Penelitian ini semata-mata dilakukan untuk kegiatan ilmiah dalam rangka penyusunan disertasi untuk memperoleh gelar Doktor (S3) pada Program Ilmu Ekonomi Pascasarjana Universitas Hasanuddin Makassar.

Data-data yang Bapak/Ibu/Sdr(i) berikan dijamin kerahasiaannya dan digunakan semata-mata untuk kepentingan ilmiah. Atas kesediaan Bapak/Ibu/Sdr(i) yang telah meluangkan waktunya untuk mengisi kuesioner ini, saya ucapkan terimakasih.

Hormat saya,

Riny Jefri

Mahasiswi Program Doktor

Pascasarjana UNHAS



PETUNJUK PENGISIAN

1. **Pernyataan kuesioner ini mengenai Presepsi anda mengenai Perguruan Tinggi Negeri (PTN) tempat anda beraktivitas, yang kemudian disebut sebagai organisasi dalam tiap pernyataan.**
2. Mohon memberi tanda silang (X) pada jawaban yang Bapak/Ibu/Sdr(i) anggap paling sesuai
3. Keterangan alternatif jawaban:
 - SS : apabila anda merasa Sangat Setuju
 - S : apabila anda merasa Setuju
 - KS : apabila anda merasa Kurang Setuju
 - TS : apabila anda merasa Tidak Setuju
 - STS : apabila anda merasa Sangat Tidak Setuju

IDENTITAS RESPONDEN

1. Nama:.....(Boleh tidak di isi)
2. Umur: < 30 tahun 31-39 tahun 40-49 tahun >50 tahun
3. Pendidikan Terakhir: SMU/SMA/SMK S1 S2 S3
4. Jenis Kelamin: Pria Wanita
5. Lama Bekerja/Studi: < 2 tahun 2-5 tahun 5-10 tahun >10 tahun
6. Unit Kerja/Progam Studi:.....
7. Jenis Pekerjaan:
 - Dosen:
 1. Status Pegawai: PNS Non PNS
 2. Menjabat di Struktural: Ya Tidak
 - Staff:
 1. Status Pegawai: PNS Non PNS
 2. Posisi:.....
 - Mahasiswa

No	PERNYATAAN	RESPON				
		SS	S	KS	TS	STS
Komitmen Organisasi						
1	Kesuksesan organisasi itu penting.	<input type="checkbox"/>	<input type="checkbox"/>	<input type="checkbox"/>	<input type="checkbox"/>	<input type="checkbox"/>
2	Setiap orang dalam organisasi bersedia melakukan tupoksi (tugas pokok) masing-masing	<input type="checkbox"/>	<input type="checkbox"/>	<input type="checkbox"/>	<input type="checkbox"/>	<input type="checkbox"/>
3	Setiap orang dalam organisasi tidak akan resign dari organisasinya.	<input type="checkbox"/>	<input type="checkbox"/>	<input type="checkbox"/>	<input type="checkbox"/>	<input type="checkbox"/>
4	Setiap orang dalam organisasi melaksanakan tupoksinya dengan maksimal.	<input type="checkbox"/>	<input type="checkbox"/>	<input type="checkbox"/>	<input type="checkbox"/>	<input type="checkbox"/>
5	Setiap orang dalam organisasi berkewajiban mendukung pencapaian tujuan organisasi.	<input type="checkbox"/>	<input type="checkbox"/>	<input type="checkbox"/>	<input type="checkbox"/>	<input type="checkbox"/>
6	Setiap orang dalam organisasi berkewajiban melakukan yang terbaik.	<input type="checkbox"/>	<input type="checkbox"/>	<input type="checkbox"/>	<input type="checkbox"/>	<input type="checkbox"/>
Budaya Organisasi						
	Organisasi beradaptasi dengan cepat terhadap perubahan yang terjadi.	<input type="checkbox"/>	<input type="checkbox"/>	<input type="checkbox"/>	<input type="checkbox"/>	<input type="checkbox"/>
	Organisasi terus-menerus mengadopsi cara baru yang lebih baik untuk melakukan kegiatannya.	<input type="checkbox"/>	<input type="checkbox"/>	<input type="checkbox"/>	<input type="checkbox"/>	<input type="checkbox"/>



No	PERNYATAAN	SS	S	KS	TS	STS
9	Saran <i>stakeholder</i> sering kali membuat perubahan dalam Organisasi.	<input type="checkbox"/>	<input type="checkbox"/>	<input type="checkbox"/>	<input type="checkbox"/>	<input type="checkbox"/>
10	Organisasi memandang kegagalan sebagai proses pembelajaran.	<input type="checkbox"/>	<input type="checkbox"/>	<input type="checkbox"/>	<input type="checkbox"/>	<input type="checkbox"/>
11	Belajar adalah tujuan penting dalam kehidupan organisasi.	<input type="checkbox"/>	<input type="checkbox"/>	<input type="checkbox"/>	<input type="checkbox"/>	<input type="checkbox"/>
12	Sebagian besar orang dalam organisasi terlibat dalam pekerjaan mereka.	<input type="checkbox"/>	<input type="checkbox"/>	<input type="checkbox"/>	<input type="checkbox"/>	<input type="checkbox"/>
13	Setiap orang dalam organisasi memberikan dampak positif.	<input type="checkbox"/>	<input type="checkbox"/>	<input type="checkbox"/>	<input type="checkbox"/>	<input type="checkbox"/>
14	Organisasi mempertimbangkan koordinasi dan kontrol horizontal untuk menyelesaikan pekerjaan.	<input type="checkbox"/>	<input type="checkbox"/>	<input type="checkbox"/>	<input type="checkbox"/>	<input type="checkbox"/>
15	Kerjasama lintas bagian dalam organisasi didorong secara aktif.	<input type="checkbox"/>	<input type="checkbox"/>	<input type="checkbox"/>	<input type="checkbox"/>	<input type="checkbox"/>
16	Organisasi selalu mendelegasikan wewenang agar dapat bertindak mandiri.	<input type="checkbox"/>	<input type="checkbox"/>	<input type="checkbox"/>	<input type="checkbox"/>	<input type="checkbox"/>
17	Organisasi terus berinovasi dalam pengembangan keterampilan.	<input type="checkbox"/>	<input type="checkbox"/>	<input type="checkbox"/>	<input type="checkbox"/>	<input type="checkbox"/>
18	Kebijakan organisasi untuk melakukan pengembangan sangat konsisten.	<input type="checkbox"/>	<input type="checkbox"/>	<input type="checkbox"/>	<input type="checkbox"/>	<input type="checkbox"/>
19	Kebijakan organisasi untuk melakukan pengembangan dapat diprediksi.	<input type="checkbox"/>	<input type="checkbox"/>	<input type="checkbox"/>	<input type="checkbox"/>	<input type="checkbox"/>
20	Setiap unit dalam organisasi memiliki perspektif yang sama.	<input type="checkbox"/>	<input type="checkbox"/>	<input type="checkbox"/>	<input type="checkbox"/>	<input type="checkbox"/>
21	Mencari solusi yang terbaik ketika terjadi perselisihan.	<input type="checkbox"/>	<input type="checkbox"/>	<input type="checkbox"/>	<input type="checkbox"/>	<input type="checkbox"/>
22	Organisasi melaksanakan sesuatu berdasarkan Standard Operating Procedure (SOP).	<input type="checkbox"/>	<input type="checkbox"/>	<input type="checkbox"/>	<input type="checkbox"/>	<input type="checkbox"/>
23	Organisasi memiliki tujuan dan arah strategis jangka panjang.	<input type="checkbox"/>	<input type="checkbox"/>	<input type="checkbox"/>	<input type="checkbox"/>	<input type="checkbox"/>
24	Pemimpin organisasi menetapkan tujuan yang secara realistis.	<input type="checkbox"/>	<input type="checkbox"/>	<input type="checkbox"/>	<input type="checkbox"/>	<input type="checkbox"/>
25	Setiap orang memiliki visi yang sama dalam organisasi.	<input type="checkbox"/>	<input type="checkbox"/>	<input type="checkbox"/>	<input type="checkbox"/>	<input type="checkbox"/>
26	Semua orang memahami cara menyukseskan organisasi dalam jangka panjang.	<input type="checkbox"/>	<input type="checkbox"/>	<input type="checkbox"/>	<input type="checkbox"/>	<input type="checkbox"/>
Kompetensi Sumber Daya Manusia						
27	Setiap orang dalam organisasi memiliki pengetahuan yang memadai untuk bertanggung jawabnya.	<input type="checkbox"/>	<input type="checkbox"/>	<input type="checkbox"/>	<input type="checkbox"/>	<input type="checkbox"/>
	Setiap orang mengetahui kegiatan organisasi yang berkaitan dengan tanggung jawabnya.	<input type="checkbox"/>	<input type="checkbox"/>	<input type="checkbox"/>	<input type="checkbox"/>	<input type="checkbox"/>
	Setiap orang dalam organisasi memiliki kemampuan teknologi organisasi dengan baik.	<input type="checkbox"/>	<input type="checkbox"/>	<input type="checkbox"/>	<input type="checkbox"/>	<input type="checkbox"/>



No	PERNYATAAN	SS	S	KS	TS	STS
30	Organisasi menyelesaikan setiap masalah dengan bijaksana.	<input type="checkbox"/>	<input type="checkbox"/>	<input type="checkbox"/>	<input type="checkbox"/>	<input type="checkbox"/>
31	Organisasi sering melakukan pelatihan untuk meningkatkan keahlian.	<input type="checkbox"/>	<input type="checkbox"/>	<input type="checkbox"/>	<input type="checkbox"/>	<input type="checkbox"/>
32	Organisasi selalu menjaga komunikasi antar unit.	<input type="checkbox"/>	<input type="checkbox"/>	<input type="checkbox"/>	<input type="checkbox"/>	<input type="checkbox"/>
33	Organisasi melaksanakan aktivitas yang bertanggung jawab kepada publik.	<input type="checkbox"/>	<input type="checkbox"/>	<input type="checkbox"/>	<input type="checkbox"/>	<input type="checkbox"/>
34	Aturan yang berlaku di organisasi selalu dipatuhi.	<input type="checkbox"/>	<input type="checkbox"/>	<input type="checkbox"/>	<input type="checkbox"/>	<input type="checkbox"/>
Pengendalian Internal						
35	Pimpinan organisasi mendorong terciptanya budaya nilai-nilai integritas.	<input type="checkbox"/>	<input type="checkbox"/>	<input type="checkbox"/>	<input type="checkbox"/>	<input type="checkbox"/>
36	Pimpinan organisasi memiliki sikap yang responsif terhadap pencapaian good governance.	<input type="checkbox"/>	<input type="checkbox"/>	<input type="checkbox"/>	<input type="checkbox"/>	<input type="checkbox"/>
37	Evaluasi kinerja merujuk pada pengendalian internal terkait.	<input type="checkbox"/>	<input type="checkbox"/>	<input type="checkbox"/>	<input type="checkbox"/>	<input type="checkbox"/>
38	Identifikasi risiko dilakukan dengan mempertimbangkan hasil sebelumnya.	<input type="checkbox"/>	<input type="checkbox"/>	<input type="checkbox"/>	<input type="checkbox"/>	<input type="checkbox"/>
39	Penentuan tingkat risiko organisasi menggunakan prinsip kehati-hatian.	<input type="checkbox"/>	<input type="checkbox"/>	<input type="checkbox"/>	<input type="checkbox"/>	<input type="checkbox"/>
40	Penentuan tingkat risiko organisasi menggunakan prinsip kewajaran.	<input type="checkbox"/>	<input type="checkbox"/>	<input type="checkbox"/>	<input type="checkbox"/>	<input type="checkbox"/>
41	Penentuan tingkat risiko organisasi menggunakan prinsip dapat dipertanggungjawabkan.	<input type="checkbox"/>	<input type="checkbox"/>	<input type="checkbox"/>	<input type="checkbox"/>	<input type="checkbox"/>
42	Sudah ada mekanisme untuk menentukan risiko.	<input type="checkbox"/>	<input type="checkbox"/>	<input type="checkbox"/>	<input type="checkbox"/>	<input type="checkbox"/>
43	Organisasi memiliki pengendalian terhadap keandalan pemrosesan data.	<input type="checkbox"/>	<input type="checkbox"/>	<input type="checkbox"/>	<input type="checkbox"/>	<input type="checkbox"/>
44	Terdapat pemisahan fungsi dalam pembagian tanggung jawab di organisasi.	<input type="checkbox"/>	<input type="checkbox"/>	<input type="checkbox"/>	<input type="checkbox"/>	<input type="checkbox"/>
45	Tanggung jawab atas transaksi di organisasi berdasarkan kewenangan yang dimiliki.	<input type="checkbox"/>	<input type="checkbox"/>	<input type="checkbox"/>	<input type="checkbox"/>	<input type="checkbox"/>
46	Pertanggungjawaban selalu disertai dengan bukti-bukti pendukung.	<input type="checkbox"/>	<input type="checkbox"/>	<input type="checkbox"/>	<input type="checkbox"/>	<input type="checkbox"/>
47	Organisasi mempunyai sistem	<input type="checkbox"/>	<input type="checkbox"/>	<input type="checkbox"/>	<input type="checkbox"/>	<input type="checkbox"/>
	masi yang baik.	<input type="checkbox"/>	<input type="checkbox"/>	<input type="checkbox"/>	<input type="checkbox"/>	<input type="checkbox"/>
	masi yang disajikan sangat	<input type="checkbox"/>	<input type="checkbox"/>	<input type="checkbox"/>	<input type="checkbox"/>	<input type="checkbox"/>
	ci.	<input type="checkbox"/>	<input type="checkbox"/>	<input type="checkbox"/>	<input type="checkbox"/>	<input type="checkbox"/>
	masi selalu diklasifikasikan	<input type="checkbox"/>	<input type="checkbox"/>	<input type="checkbox"/>	<input type="checkbox"/>	<input type="checkbox"/>
	ai dengan kebijakan organisasi.	<input type="checkbox"/>	<input type="checkbox"/>	<input type="checkbox"/>	<input type="checkbox"/>	<input type="checkbox"/>
	nisasi selalu melakukan	<input type="checkbox"/>	<input type="checkbox"/>	<input type="checkbox"/>	<input type="checkbox"/>	<input type="checkbox"/>
	antauan berkelanjutan.	<input type="checkbox"/>	<input type="checkbox"/>	<input type="checkbox"/>	<input type="checkbox"/>	<input type="checkbox"/>



No	PERNYATAAN	SS	S	KS	TS	STS
51	Evaluasi meliputi review terhadap rancangan pengendalian internal.	<input type="checkbox"/>	<input type="checkbox"/>	<input type="checkbox"/>	<input type="checkbox"/>	<input type="checkbox"/>
52	Laporan pemantauan menjadi data pengambilan keputusan organisasi.	<input type="checkbox"/>	<input type="checkbox"/>	<input type="checkbox"/>	<input type="checkbox"/>	<input type="checkbox"/>
Good Governance						
53	Organisasi mematuhi peraturan perundang-undang dalam pelaksanaan kegiatannya.	<input type="checkbox"/>	<input type="checkbox"/>	<input type="checkbox"/>	<input type="checkbox"/>	<input type="checkbox"/>
54	Organisasi dilengkapi dengan unit layanan pengaduan masyarakat.	<input type="checkbox"/>	<input type="checkbox"/>	<input type="checkbox"/>	<input type="checkbox"/>	<input type="checkbox"/>
55	Organisasi menetapkan rincian tanggung jawab masing-masing unit.	<input type="checkbox"/>	<input type="checkbox"/>	<input type="checkbox"/>	<input type="checkbox"/>	<input type="checkbox"/>
56	Organisasi dilengkapi dengan sistem pengendalian internal yang membantu dalam melaksanakan tugasnya.	<input type="checkbox"/>	<input type="checkbox"/>	<input type="checkbox"/>	<input type="checkbox"/>	<input type="checkbox"/>
57	Organisasi memiliki sistem penilaian kinerja	<input type="checkbox"/>	<input type="checkbox"/>	<input type="checkbox"/>	<input type="checkbox"/>	<input type="checkbox"/>
58	Organisasi memiliki kode etik yang telah disepakati.	<input type="checkbox"/>	<input type="checkbox"/>	<input type="checkbox"/>	<input type="checkbox"/>	<input type="checkbox"/>
59	Organisasi memberikan kesempatan kepada pihak yang berkepentingan untuk memberikan masukan.	<input type="checkbox"/>	<input type="checkbox"/>	<input type="checkbox"/>	<input type="checkbox"/>	<input type="checkbox"/>
60	Organisasi memberikan perlakuan yang wajar kepada semua pihak.	<input type="checkbox"/>	<input type="checkbox"/>	<input type="checkbox"/>	<input type="checkbox"/>	<input type="checkbox"/>
61	Organisasi tidak membedakan suku, agama, ras, golongan, gender dan kondisi fisik dalam penerimaan karyawan.	<input type="checkbox"/>	<input type="checkbox"/>	<input type="checkbox"/>	<input type="checkbox"/>	<input type="checkbox"/>
62	Organisasi menyediakan informasi yang dapat diakses dengan mudah.	<input type="checkbox"/>	<input type="checkbox"/>	<input type="checkbox"/>	<input type="checkbox"/>	<input type="checkbox"/>
63	Organisasi memberikan informasi yang berdampak pada masyarakat.	<input type="checkbox"/>	<input type="checkbox"/>	<input type="checkbox"/>	<input type="checkbox"/>	<input type="checkbox"/>
64	Kerahasiaan informasi tetap terjaga sesuai dengan peraturan perundang-undangan.	<input type="checkbox"/>	<input type="checkbox"/>	<input type="checkbox"/>	<input type="checkbox"/>	<input type="checkbox"/>
65	Kebijakan organisasi dikomunikasikan secara tertulis kepada semua pihak yang berkepentingan.	<input type="checkbox"/>	<input type="checkbox"/>	<input type="checkbox"/>	<input type="checkbox"/>	<input type="checkbox"/>
66	Pengambilan keputusan organisasi tidak diintervensi oleh pihak lain.	<input type="checkbox"/>	<input type="checkbox"/>	<input type="checkbox"/>	<input type="checkbox"/>	<input type="checkbox"/>
67	Kejelasan penanggungjawab dalam pelaksanaan kegiatan organisasi.	<input type="checkbox"/>	<input type="checkbox"/>	<input type="checkbox"/>	<input type="checkbox"/>	<input type="checkbox"/>
68	Pelaksanaan kegiatan organisasi didominasi oleh pihak tertentu.	<input type="checkbox"/>	<input type="checkbox"/>	<input type="checkbox"/>	<input type="checkbox"/>	<input type="checkbox"/>



Saran yang berkaitan dengan topik penelitian ini dapat disampaikan melalui form di bawah ini:

Terimakasih banyak atas waktu yang Bapak/Ibu/Sdr(i) luangkan untuk mengisi kuesioner ini.



Lampiran: Hasil Uji Analisis Jalur

Uji Validitas dan Realibilitas

1. Komitmen Organisasi (X.1)

Correlations

		ToTal
X1.1	Pearson Correlation	.526**
	Sig. (2-tailed)	0
X1.2	Pearson Correlation	.562**
	Sig. (2-tailed)	0
X1.3	Pearson Correlation	.478**
	Sig. (2-tailed)	0
X1.4	Pearson Correlation	.595**
	Sig. (2-tailed)	0
X1.5	Pearson Correlation	.619**
	Sig. (2-tailed)	0
X1.6	Pearson Correlation	.518**
	Sig. (2-tailed)	0

** . Correlation is significant at the 0.01 level (2-tailed).

Reliability Statistics

Cronbach's Alpha	N of Items
.510	6



2. Budaya Organisasi (X.2)

Correlations

		Total
X2.1	Pearson Correlation	.572
	Sig. (2-tailed)	.000**
X2.2	Pearson Correlation	.556
	Sig. (2-tailed)	.000**
X2.3	Pearson Correlation	.426
	Sig. (2-tailed)	.000**
X2.4	Pearson Correlation	.493
	Sig. (2-tailed)	.000**
X2.5	Pearson Correlation	.435
	Sig. (2-tailed)	.000**
X2.6	Pearson Correlation	.555
	Sig. (2-tailed)	.000**
X2.7	Pearson Correlation	.549
	Sig. (2-tailed)	.000**
X2.8	Pearson Correlation	.540**
	Sig. (2-tailed)	.000**
X2.9	Pearson Correlation	0.619
	Sig. (2-tailed)	.000**
X2.10	Pearson Correlation	0.568
	Sig. (2-tailed)	.000**
X2.11	Pearson Correlation	0.517
	Sig. (2-tailed)	.000**
X2.12	Pearson Correlation	0.663
	Sig. (2-tailed)	.000**
X2.13	Pearson Correlation	0.599
	Sig. (2-tailed)	.000**
X2.14	Pearson Correlation	0.549
	Sig. (2-tailed)	.000**
X2.15	Pearson Correlation	0.466
	Sig. (2-tailed)	.000**
X2.16	Pearson Correlation	0.491
	Sig. (2-tailed)	.000**
X2.17	Pearson Correlation	0.41
	Sig. (2-tailed)	.000**
X2.18	Pearson Correlation	0.499
	Sig. (2-tailed)	.000**
	Pearson Correlation	0.515
	Sig. (2-tailed)	.000**
	Pearson Correlation	0.549
	Sig. (2-tailed)	.000**

Reliability Statistics

Cronbach's Alpha	N of Items
.862	20

** . Correlation is significant at the 0.01 level (2-tailed).



3. Kompetensi Sumber Daya Manusia (X.3)

Correlations

		Total
X3.1	Pearson Correlation	.691**
	Sig. (2-tailed)	.000**
X3.2	Pearson Correlation	.703**
	Sig. (2-tailed)	.000**
X3.3	Pearson Correlation	.743**
	Sig. (2-tailed)	.000**
X3.4	Pearson Correlation	.689**
	Sig. (2-tailed)	.000**
X3.5	Pearson Correlation	.590**
	Sig. (2-tailed)	.000**
X3.6	Pearson Correlation	.687**
	Sig. (2-tailed)	.000**
X3.7	Pearson Correlation	.549**
	Sig. (2-tailed)	.000**
X3.8	Pearson Correlation	.661**
	Sig. (2-tailed)	.000**

** . Correlation is significant at the 0.01 level (2-tailed).

Reliability Statistics

Cronbach's Alpha	N of Items
.818	8



4. Pengendalian Internal (Y.1)

Correlations

		Total
Y1.1	Pearson Correlation	.603**
	Sig. (2-tailed)	.000**
Y1.2	Pearson Correlation	.608**
	Sig. (2-tailed)	.000**
Y1.3	Pearson Correlation	.639**
	Sig. (2-tailed)	.000**
Y1.4	Pearson Correlation	.622**
	Sig. (2-tailed)	.000**
Y1.5	Pearson Correlation	.647**
	Sig. (2-tailed)	.000**
Y1.6	Pearson Correlation	.558**
	Sig. (2-tailed)	.000**
Y1.7	Pearson Correlation	.632**
	Sig. (2-tailed)	.000**
Y1.8	Pearson Correlation	0.662
Y1.9	Sig. (2-tailed)	.000**
	Pearson Correlation	0.658
Y1.10	Sig. (2-tailed)	.000**
	Pearson Correlation	0.579
Y1.11	Sig. (2-tailed)	.000**
	Pearson Correlation	0.529
Y1.12	Sig. (2-tailed)	.000**
	Pearson Correlation	0.567
Y1.13	Sig. (2-tailed)	.000**
	Pearson Correlation	0.683
Y1.14	Sig. (2-tailed)	.000**
	Pearson Correlation	0.711
Y1.15	Sig. (2-tailed)	.000**
	Pearson Correlation	0.65
Y1.16	Sig. (2-tailed)	.000**
	Pearson Correlation	0.728
	Sig. (2-tailed)	.000**
	Pearson Correlation	0.672
	Sig. (2-tailed)	.000**
	Pearson Correlation	0.709
	Sig. (2-tailed)	.000**

Reliability Statistics

Cronbach's Alpha	N of Items
.913	18



5. Good Governance (Y.2)

Correlations

		Total
Y2.1	Pearson Correlation	.577**
	Sig. (2-tailed)	.000**
Y2.2	Pearson Correlation	.639**
	Sig. (2-tailed)	.000**
Y2.3	Pearson Correlation	.593**
	Sig. (2-tailed)	.000**
Y2.4	Pearson Correlation	.629**
	Sig. (2-tailed)	.000**
Y2.5	Pearson Correlation	.660**
	Sig. (2-tailed)	.000**
Y2.6	Pearson Correlation	0.689
	Sig. (2-tailed)	.000**
Y2.7	Pearson Correlation	.687**
	Sig. (2-tailed)	.000**
Y2.8	Pearson Correlation	.731**
	Sig. (2-tailed)	.000**
Y2.9	Pearson Correlation	0.622
	Sig. (2-tailed)	.000**
Y2.10	Pearson Correlation	0.684
	Sig. (2-tailed)	.000**
Y2.11	Pearson Correlation	0.643
	Sig. (2-tailed)	.000**
Y2.12	Pearson Correlation	0.643
	Sig. (2-tailed)	.000**
Y2.13	Pearson Correlation	0.631
	Sig. (2-tailed)	.000**
Y2.14	Pearson Correlation	0.637
	Sig. (2-tailed)	.000**
Y2.15	Pearson Correlation	0.639
	Sig. (2-tailed)	.000**
Y2.16	Pearson Correlation	0.646
	Sig. (2-tailed)	.000**

** . Correlation is significant at the 0.01 level (2-tailed).

Reliability Statistics

Cronbach's Alpha	N of Items
.907	16



Lampiran: Descriptive Statistics

Descriptive Statistics						
	N	Minimum	Maximum	Sum	Mean	Std. Deviation
X1.1	326	4.00	5.00	1507.00	4.6227	.48546
X1.2	326	4.00	5.00	1448.00	4.4417	.49735
X1.3	326	2.00	5.00	1151.00	3.5307	.75078
X1.4	326	3.00	5.00	1383.00	4.2423	.59188
X1.5	326	3.00	5.00	1494.00	4.5828	.51220
X1.6	326	3.00	5.00	1489.00	4.5675	.50844
X2.1	326	3.00	5.00	1348.00	4.1350	.56039
X2.2	326	3.00	5.00	1372.00	4.2086	.57597
X2.3	326	3.00	5.00	1289.00	3.9540	.60843
X2.4	326	3.00	5.00	1385.00	4.2485	.59452
X2.5	326	3.00	5.00	1463.00	4.4877	.53623
X2.6	326	3.00	5.00	1348.00	4.1350	.51459
X2.7	326	3.00	5.00	1318.00	4.0429	.63099
X2.8	326	3.00	5.00	1344.00	4.1227	.49332
X2.9	326	3.00	5.00	1360.00	4.1718	.52735
X2.10	326	3.00	5.00	1321.00	4.0521	.57140
X2.11	326	3.00	5.00	1400.00	4.2945	.51360
X2.12	326	3.00	5.00	1334.00	4.0920	.54699
X2.13	326	3.00	5.00	1271.00	3.8988	.58087
X2.14	326	2.00	5.00	1201.00	3.6840	.74101
X2.15	326	3.00	5.00	1446.00	4.4356	.54391



Descriptive Statistics

	N	Minimum	Maximum	Sum	Mean	Std. Deviation
X2.16	326	3.00	5.00	1427.00	4.3773	.56184
X2.17	326	3.00	5.00	1441.00	4.4202	.51269
X2.18	326	3.00	5.00	1406.00	4.3129	.50865
X2.19	326	2.00	5.00	1283.00	3.9356	.66944
X2.20	326	3.00	5.00	1287.00	3.9479	.62785
X3.1	326	3.00	5.00	1341.00	4.1135	.57859
X3.2	326	3.00	5.00	1365.00	4.1871	.56456
X3.3	326	2.00	5.00	1271.00	3.8988	.67405
X3.4	326	3.00	5.00	1373.00	4.2117	.55023
X3.5	326	3.00	5.00	1377.00	4.2239	.58350
X3.6	326	3.00	5.00	1388.00	4.2577	.53882
X3.7	326	3.00	5.00	1379.00	4.2301	.53707
X3.8	326	2.00	5.00	1315.00	4.0337	.67625
Y1.1	326	3.00	5.00	1377.00	4.2239	.51636
Y1.2	326	3.00	5.00	1407.00	4.3160	.52170
Y1.3	326	3.00	5.00	1363.00	4.1810	.47821
Y1.4	326	3.00	5.00	1358.00	4.1656	.46095
Y1.5	326	3.00	5.00	1359.00	4.1687	.50145
Y1.6	326	3.00	5.00	1322.00	4.0552	.53495
Y1.7	326	3.00	5.00	1376.00	4.2209	.47749
Y1.8	326	2.00	5.00	1305.00	4.0031	.60510



Descriptive Statistics

	N	Minimum	Maximum	Sum	Mean	Std. Deviation
Y1.9	326	2.00	5.00	1333.00	4.0890	.56137
Y1.10	326	3.00	5.00	1365.00	4.1871	.51317
Y1.11	326	3.00	5.00	1361.00	4.1748	.50546
Y1.12	326	3.00	5.00	1440.00	4.4172	.56368
Y1.13	326	3.00	5.00	1390.00	4.2638	.60080
Y1.14	326	2.00	5.00	1345.00	4.1258	.65126
Y1.15	326	3.00	5.00	1344.00	4.1227	.53520
Y1.16	326	3.00	5.00	1365.00	4.1871	.55355
Y1.17	326	3.00	5.00	1351.00	4.1442	.51508
Y1.18	326	3.00	5.00	1371.00	4.2055	.52398
Y2.1	326	3.00	5.00	1395.00	4.2791	.50717
Y2.2	326	2.00	5.00	1334.00	4.0920	.65923
Y2.3	326	3.00	5.00	1387.00	4.2546	.50799
Y2.4	326	3.00	5.00	1400.00	4.2945	.53127
Y2.5	326	3.00	5.00	1403.00	4.3037	.54613
Y2.6	326	3.00	5.00	1403.00	4.3037	.55174
Y2.7	326	3.00	5.00	1374.00	4.2147	.55183
Y2.8	326	3.00	5.00	1377.00	4.2239	.61432
Y2.9	326	3.00	5.00	1444.00	4.4294	.58145
Y2.10	326	3.00	5.00	1382.00	4.2393	.57469
Y2.11	326	3.00	5.00	1376.00	4.2209	.56595

Descriptive Statistics

	N	Minimum	Maximum	Sum	Mean	Std. Deviation
Y2.12	326	3.00	5.00	1406.00	4.3129	.52061
Y2.13	326	3.00	5.00	1363.00	4.1810	.59826
Y2.14	326	3.00	5.00	1367.00	4.1933	.57866
Y2.15	326	3.00	5.00	1394.00	4.2761	.51785
Y2.16	326	2.00	5.00	1366.00	4.1902	.59797
Valid N (listwise)	326					



LAMPIRAN: Hasil Uji CFA AMOS

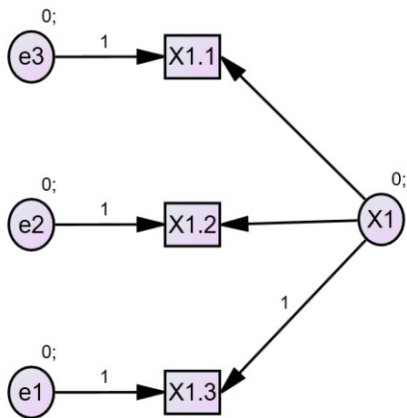

Maximum Likelihood Estimates

Regression Weights: (Group number 1 - Default model)

	Estimate	S.E.	C.R.	P	Label
X1.3 <--- X1	1.000				
X1.2 <--- X1	.796	.226	3.521	***	par_1
X1.1 <--- X1	1.300	.481	2.705	.007	par_2

Standardized Regression Weights: (Group number 1 - Default model)

	Estimate
X1.3 <--- X1	.476
X1.2 <--- X1	.321
X1.1 <--- X1	.680

Intercepts: (Group number 1 - Default model)

	Estimate	S.E.	C.R.	P	Label
X1.3	9.150	.047	194.858	***	par_3
X1.2	7.773	.055	140.302	***	par_4
X1.1	9.064	.043	212.024	***	par_5

Squared Multiple Correlations: (Group number 1 - Default model)

	Estimate
	.462
	.103
	.227



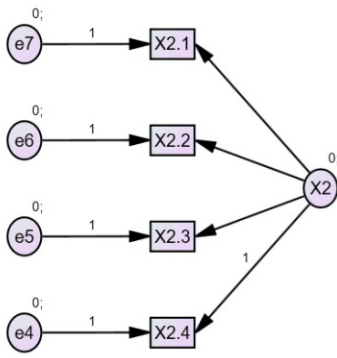

Maximum Likelihood Estimates

Regression Weights: (Group number 1 - Default model)

	Estimate	S.E.	C.R.	P	Label
X2.4 <--- X2	1.000				
X2.3 <--- X2	1.814	.155	11.668	***	par_1
X2.2 <--- X2	1.401	.138	10.177	***	par_2
X2.1 <--- X2	1.244	.129	9.604	***	par_3

Standardized Regression Weights: (Group number 1 - Default model)

	Estimate
X2.4 <--- X2	.638
X2.3 <--- X2	.841
X2.2 <--- X2	.757
X2.1 <--- X2	.694

Intercepts: (Group number 1 - Default model)

	Estimate	S.E.	C.R.	P	Label
X2.4	16.617	.088	189.218	***	par_4
X2.3	24.782	.121	205.187	***	par_5
X2.2	20.525	.104	198.101	***	par_6
X2.1	21.034	.100	209.633	***	par_7

Squared Multiple Correlations: (Group number 1 - Default model)

	Estimate
X2.1	.482
	.574
	.708
	.407



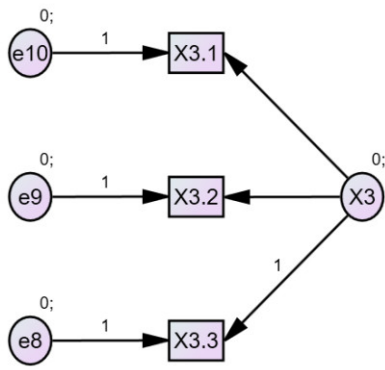

Maximum Likelihood Estimates

Regression Weights: (Group number 1 - Default model)

	Estimate	S.E.	C.R.	P	Label
X3.3 <--- X3	1.000				
X3.2 <--- X3	1.461	.156	9.389	***	par_1
X3.1 <--- X3	1.683	.179	9.386	***	par_2

Standardized Regression Weights: (Group number 1 - Default model)

	Estimate
X3.3 <--- X3	.677
X3.2 <--- X3	.737
X3.1 <--- X3	.740

Intercepts: (Group number 1 - Default model)

	Estimate	S.E.	C.R.	P	Label
X3.3	8.264	.054	152.944	***	par_3
X3.2	12.693	.073	175.012	***	par_4
X3.1	12.199	.083	146.564	***	par_5

Squared Multiple Correlations: (Group number 1 - Default model)

	Estimate
X3.1	.548
X3.2	.544
X3.3	.459



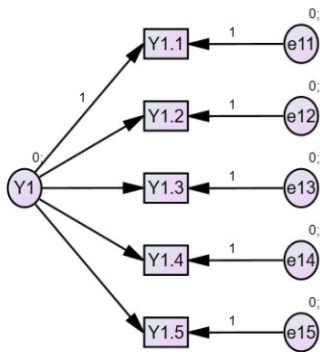

Maximum Likelihood Estimates

Regression Weights: (Group number 1 - Default model)

	Estimate	S.E.	C.R.	P	Label
Y1.1 <--- Y1	1.000				
Y1.2 <--- Y1	1.740	.131	13.316	***	par_1
Y1.3 <--- Y1	1.338	.109	12.317	***	par_2
Y1.4 <--- Y1	1.357	.103	13.172	***	par_3
Y1.5 <--- Y1	1.272	.095	13.378	***	par_4

Standardized Regression Weights: (Group number 1 - Default model)

	Estimate
Y1.1 <--- Y1	.703
Y1.2 <--- Y1	.806
Y1.3 <--- Y1	.750
Y1.4 <--- Y1	.800
Y1.5 <--- Y1	.823

Intercepts: (Group number 1 - Default model)

	Estimate	S.E.	C.R.	P	Label
Y1.1	12.721	.068	187.515	***	par_5
Y1.2	20.613	.103	200.195	***	par_6
Y1.3	16.868	.085	198.210	***	par_7
Y1.4	12.512	.081	154.660	***	par_8
Y1.5	12.537	.074	170.169	***	par_9



Squared Multiple Correlations: (Group number 1 - Default model)

	Estimate
Y1.5	.678
Y1.4	.640
Y1.3	.563
Y1.2	.649
Y1.1	.494

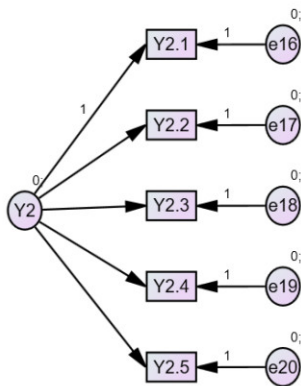

Maximum Likelihood Estimates

Regression Weights: (Group number 1 - Default model)

	Estimate	S.E.	C.R.	P	Label
Y2.1 <--- Y2	1.000				
Y2.2 <--- Y2	1.917	.147	13.069	***	par_1
Y2.3 <--- Y2	1.728	.132	13.113	***	par_2
Y2.4 <--- Y2	2.066	.161	12.794	***	par_3
Y2.5 <--- Y2	1.447	.131	11.085	***	par_4

Standardized Regression Weights: (Group number 1 - Default model)

	Estimate
Y2.1 <--- Y2	.702
Y2.2 <--- Y2	.777
Y2.3 <--- Y2	.830
Y2.4 <--- Y2	.815
Y2.5 <--- Y2	.685



Intercepts: (Group number 1 - Default model)

	Estimate	S.E.	C.R.	P	Label
Y2.1	8.371	.053	158.353	***	par_5
Y2.2	17.156	.092	187.293	***	par_6
Y2.3	12.868	.077	166.437	***	par_7
Y2.4	16.954	.094	180.156	***	par_8
Y2.5	12.660	.078	161.476	***	par_9

Squared Multiple Correlations: (Group number 1 - Default model)

	Estimate
Y2.5	.469
Y2.4	.664
Y2.3	.688
Y2.2	.603
Y2.1	.493



Lampiran: Hasil uji awal Data 326

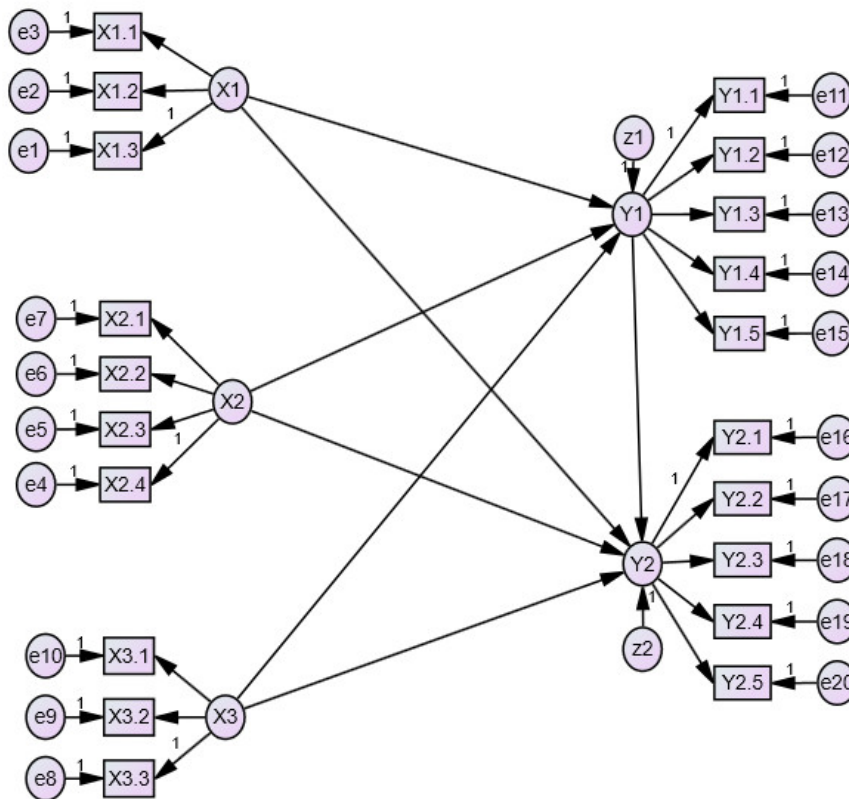

Notes for Group (Group number 1)

The model is recursive.

Sample size = 326

Notes for Model (Default model)

Computation of degrees of freedom (Default model)

Number of distinct sample moments:	230
Number of distinct parameters to be estimated:	67
Degrees of freedom (230 - 67):	163

Result (Default model)

Minimum was achieved

667,985
 freedom = 163
 level = ,000



Your model contains the following variables (Group number 1)

Observed, endogenous variables

X1.3

X1.2

X1.1

X2.4

X2.3

X2.2

X2.1

X3.3

X3.2

X3.1

Y1.1

Y1.2

Y1.3

Y1.4

Y1.5

Y2.1

Y2.2

Y2.3

Y2.4

Y2.5

Unobserved, endogenous variables

Y1

Y2

Unobserved, exogenous variables

X1

e1

e2

e3

X2

e4

e5

e6

e7

X3

e8

e9

e10

e11

e12

e13

e14

e15

e16

e17

e18

e19

e20

z1

z2

Parameter Summary (Group number 1)

	Weights	Covariances	Variances	Means	Intercepts	Total
Fixed	27	0	0	25	2	54
Labeled	0	0	0	0	0	0
Unlabeled	22	0	25	0	20	67
Total	49	0	25	25	22	121



Assessment of normality (Group number 1)

Variable	min	max	skew	c.r.	kurtosis	c.r.
Y2.5	9,000	15,000	,127	,937	-,218	-,803
Y2.4	12,000	20,000	,057	,419	-,384	-1,417
Y2.3	9,000	15,000	,080	,588	-,778	-2,867
Y2.2	12,000	20,000	,109	,806	-,310	-1,142
Y2.1	5,000	10,000	,073	,539	-,146	-,539
Y1.5	9,000	15,000	,255	1,877	,145	,534
Y1.4	9,000	15,000	-,131	-,966	-,188	-,692
Y1.3	12,000	20,000	,161	1,186	,190	,699
Y1.2	15,000	25,000	,536	3,950	,429	1,582
Y1.1	9,000	15,000	,333	2,453	-,120	-,441
X3.1	9,000	15,000	,023	,170	-,176	-,649
X3.2	9,000	15,000	,077	,569	-,112	-,413
X3.3	6,000	10,000	-,029	-,215	-,402	-1,481
X2.1	16,000	25,000	,080	,592	-,172	-,632
X2.2	15,000	25,000	,416	3,068	,091	,337
X2.3	19,000	30,000	,041	,303	-,151	-,558
X2.4	13,000	20,000	,255	1,876	-,448	-1,651
X1.1	8,000	10,000	-,111	-,815	-1,310	-4,827
X1.2	5,000	10,000	,041	,301	-,409	-1,506
X1.3	7,000	10,000	-,351	-2,589	-1,358	-5,005
Multivariate					66,674	20,290

Observations farthest from the centroid (Mahalanobis distance) (Group number 1)

Observation number	Mahalanobis d-squared	p1	p2
12	62,740	,000	,001
260	58,899	,000	,000
223	56,312	,000	,000
307	52,568	,000	,000
13	47,089	,001	,000
1	44,129	,001	,000
109	42,560	,002	,000
156	42,304	,003	,000
50	42,274	,003	,000
317	42,065	,003	,000
31	41,157	,004	,000
29	39,315	,006	,000
8	38,116	,009	,000
3	37,574	,010	,000
5	37,495	,010	,000



Observation number	Mahalanobis d-squared	p1	p2
279	37,229	,011	,000
274	37,088	,011	,000
123	36,911	,012	,000
293	36,607	,013	,000
313	36,449	,014	,000
7	35,611	,017	,000
213	35,550	,017	,000
6	35,191	,019	,000
315	35,014	,020	,000
270	34,326	,024	,000
57	34,166	,025	,000
309	34,010	,026	,000
20	33,902	,027	,000
119	33,653	,029	,000
147	33,599	,029	,000
49	33,499	,030	,000
190	33,448	,030	,000
306	33,095	,033	,000
17	33,078	,033	,000
232	32,675	,037	,000
169	32,307	,040	,000
324	32,096	,042	,000
322	32,055	,043	,000
167	32,008	,043	,000
231	31,964	,044	,000
201	31,804	,045	,000
9	31,612	,048	,000
295	31,421	,050	,000
159	31,119	,054	,000
233	31,072	,054	,000
236	31,018	,055	,000
164	30,855	,057	,000
210	30,784	,058	,000
183	30,671	,060	,000
46	30,598	,061	,000
214	30,530	,062	,000
291	30,458	,063	,000
202	29,873	,072	,000
177	29,754	,074	,000
121	29,495	,078	,000
141	29,424	,080	,000
282	29,369	,081	,000
262	29,211	,084	,000



Observation number	Mahalanobis d-squared	p1	p2
275	29,197	,084	,000
162	29,098	,086	,000
4	29,044	,087	,000
263	28,934	,089	,000
27	28,888	,090	,000
272	28,615	,096	,000
185	28,442	,099	,000
305	28,064	,108	,000
264	27,929	,111	,000
237	27,874	,112	,000
238	27,452	,123	,000
111	27,328	,126	,000
227	27,116	,132	,000
124	27,038	,134	,000
297	26,823	,140	,000
45	26,821	,140	,000
290	26,819	,140	,000
10	26,802	,141	,000
146	26,717	,143	,000
320	26,598	,147	,000
199	26,534	,149	,000
59	26,313	,156	,000
181	26,151	,161	,000
182	26,102	,162	,000
197	25,996	,166	,000
207	25,934	,168	,000
47	25,578	,180	,000
139	25,344	,189	,001
176	25,136	,196	,001
287	25,012	,201	,002
122	24,992	,202	,001
281	24,782	,210	,003
289	24,707	,213	,003
283	24,660	,215	,002
160	24,618	,216	,002
251	24,592	,217	,002
142	24,574	,218	,001
28	24,518	,220	,001
234	24,432	,224	,001
33	24,292	,230	,002
269	24,273	,231	,001
258	24,235	,232	,001



Estimates (Group number 1 - Default model)

Scalar Estimates (Group number 1 - Default model)

Maximum Likelihood Estimates

Regression Weights: (Group number 1 - Default model)

		Estimate	S.E.	C.R.	P	Label
Y1	<--- X1	,150	,100	1,493	,136	par_16
Y1	<--- X2	,386	,061	6,376	***	par_17
Y1	<--- X3	,687	,097	7,100	***	par_19
Y2	<--- X2	-,052	,049	-1,053	,292	par_18
Y2	<--- X3	,085	,087	,969	,332	par_20
Y2	<--- X1	,112	,072	1,555	,120	par_21
Y2	<--- Y1	,770	,106	7,254	***	par_22
X1.3	<--- X1	1,000				
X1.2	<--- X1	,616	,235	2,617	,009	par_1
X1.1	<--- X1	,835	,300	2,783	,005	par_2
X2.4	<--- X2	1,000				
X2.3	<--- X2	1,806	,153	11,778	***	par_3
X2.2	<--- X2	1,394	,133	10,443	***	par_4
X2.1	<--- X2	1,274	,129	9,912	***	par_5
X3.3	<--- X3	1,000				
X3.2	<--- X3	1,553	,148	10,480	***	par_6
X3.1	<--- X3	1,566	,153	10,235	***	par_7
Y1.1	<--- Y1	1,000				
Y1.2	<--- Y1	1,731	,124	13,979	***	par_8
Y1.3	<--- Y1	1,301	,103	12,670	***	par_9
Y1.4	<--- Y1	1,359	,097	13,950	***	par_10
Y1.5	<--- Y1	1,275	,089	14,272	***	par_11
Y2.1	<--- Y2	1,000				
Y2.2	<--- Y2	1,929	,124	15,546	***	par_12
Y2.3	<--- Y2	1,568	,107	14,621	***	par_13
Y2.4	<--- Y2	1,827	,131	13,910	***	par_14
Y2.5	<--- Y2	1,281	,111	11,578	***	par_15



Standardized Regression Weights: (Group number 1 - Default model)

	Estimate
Y1 <--- X1	,106
Y1 <--- X2	,543
Y1 <--- X3	,632
Y2 <--- X2	-,088
Y2 <--- X3	,094
Y2 <--- X1	,095
Y2 <--- Y1	,926
X1.3 <--- X1	,597
X1.2 <--- X1	,312
X1.1 <--- X1	,547
X2.4 <--- X2	,636
X2.3 <--- X2	,835
X2.2 <--- X2	,752
X2.1 <--- X2	,710
X3.3 <--- X3	,677
X3.2 <--- X3	,783
X3.1 <--- X3	,688
Y1.1 <--- Y1	,637
Y1.2 <--- Y1	,748
Y1.3 <--- Y1	,666
Y1.4 <--- Y1	,747
Y1.5 <--- Y1	,776
Y2.1 <--- Y2	,685
Y2.2 <--- Y2	,782
Y2.3 <--- Y2	,746
Y2.4 <--- Y2	,707
Y2.5 <--- Y2	,577



Intercepts: (Group number 1 - Default model)

	Estimate	S.E.	C.R.	P	Label
X1.3	9,150	,047	194,858	***	par_23
X1.2	7,773	,055	140,302	***	par_24
X1.1	9,064	,043	212,024	***	par_25
X2.4	16,617	,088	189,218	***	par_26
X2.3	24,782	,121	205,187	***	par_27
X2.2	20,525	,104	198,101	***	par_28
X2.1	21,034	,100	209,633	***	par_29
X3.3	8,264	,054	152,944	***	par_30
X3.2	12,693	,073	175,012	***	par_31
X3.1	12,199	,083	146,564	***	par_32
Y1.1	12,721	,062	204,130	***	par_33
Y1.2	20,613	,092	224,277	***	par_34
Y1.3	16,868	,078	217,290	***	par_35
Y1.4	12,512	,072	173,228	***	par_36
Y1.5	12,537	,065	192,090	***	par_37
Y2.1	8,371	,048	173,586	***	par_38
Y2.2	17,156	,082	210,450	***	par_39
Y2.3	12,868	,069	185,271	***	par_40
Y2.4	16,954	,085	198,561	***	par_41
Y2.5	12,660	,073	172,652	***	par_42



Variances: (Group number 1 - Default model)

	Estimate	S.E.	C.R.	P	Label
X1	,255	,101	2,534	,011	par_43
X2	1,014	,171	5,929	***	par_44
X3	,435	,070	6,175	***	par_45
z1	,151	,031	4,842	***	par_46
z2	,028	,013	2,074	,038	par_47
e1	,461	,098	4,704	***	par_48
e2	,901	,081	11,144	***	par_49
e3	,416	,072	5,774	***	par_50
e4	1,492	,134	11,116	***	par_51
e5	1,432	,200	7,165	***	par_52
e6	1,518	,159	9,526	***	par_53
e7	1,624	,161	10,111	***	par_54
e8	,514	,052	9,956	***	par_55
e9	,662	,085	7,743	***	par_56
e10	1,186	,120	9,889	***	par_57
e11	,749	,063	11,866	***	par_58
e12	1,208	,110	11,035	***	par_59
e13	1,091	,093	11,671	***	par_60
e14	,748	,067	11,107	***	par_61
e15	,551	,052	10,696	***	par_62
e16	,401	,035	11,499	***	par_63
e17	,841	,080	10,481	***	par_64
e18	,696	,065	10,747	***	par_65
e19	1,186	,107	11,056	***	par_66
e20	1,165	,098	11,931	***	par_67



Squared Multiple Correlations: (Group number 1 - Default model)

	Estimate
Y1	,706
Y2	,922
Y2.5	,333
Y2.4	,500
Y2.3	,556
Y2.2	,611
Y2.1	,469
Y1.5	,602
Y1.4	,559
Y1.3	,443
Y1.2	,560
Y1.1	,406
X3.1	,473
X3.2	,613
X3.3	,458
X2.1	,504
X2.2	,565
X2.3	,698
X2.4	,405
X1.1	,300
X1.2	,097
X1.3	,356

Model Fit Summary

CMIN

Model	NPAR	CMIN	DF	P	CMIN/DF
Default model	67	667,985	163	,000	4,098
Saturated model	230	,000	0		
Independence model	40	3763,095	190	,000	19,806

RMSEA

Model	RMSEA	LO 90	HI 90	PCLOSE
Default model	,098	,090	,105	,000
Independence model	,241	,234	,247	,000



LAMPIRAN: Hasil setelah Normal dan Outlier Teratasi.

Syarat normal apabila nilai c.r.berada pada rentang +- 2.58. ada beberapa yang tidak berada pada rentang tersebut, sehingga perlu dilakukan transformasi.

Syarat nilai mahalanobis apabila lebih kecil dari chi square (0.001, df) df=20, maka bukan outlier. Jadi dengan excel diperoleh dengan $\text{chisq.inv.rt}(0.001,20)=45,31475$.

Assessment of normality (Group number 1)

Variable	min	max	skew	c.r.	kurtosis	c.r.
Y2.5	9.000	15.000	.159	1.157	-.141	-.514
Y2.4	13.000	20.000	.125	.911	-.436	-1.587
Y2.3	4.893	20.569	.010	.072	-.024	-.088
Y2.2	13.000	20.000	.195	1.423	-.444	-1.618
Y2.1	5.000	10.000	.108	.784	-.153	-.559
Y1.5	9.000	15.000	.247	1.795	.155	.564
Y1.4	9.000	15.000	-.131	-.956	-.165	-.599
Y1.3	12.000	20.000	.208	1.512	.247	.897
Y1.2	14.794	24.573	.005	.038	.011	.040
Y1.1	9.629	14.845	.061	.445	-.160	-.583
X3.1	9.000	15.000	.028	.201	-.138	-.501
X3.2	9.000	15.000	.128	.932	-.142	-.516
X3.3	6.000	10.000	-.030	-.218	-.401	-1.460
X2.1	16.000	25.000	.141	1.030	-.228	-.828
X2.2	14.729	24.757	-.033	-.238	.038	.139
X2.3	19.000	30.000	.120	.873	-.207	-.755
X2.4	13.000	20.000	.259	1.888	-.444	-1.617
X1.1	8.006	10.005	-.079	-.578	-1.290	-4.697
X1.2	5.000	10.000	.032	.236	-.408	-1.483
X1.3	6.312	10.006	-.347	-2.525	-1.198	-4.361
Multivariate					49.620	14.914

Observations farthest from the centroid (Mahalanobis distance) (Group number 1)

Observation number	Mahalanobis d-squared	p1	p2
264	44.325	.001	.352
47	42.866	.002	.148
106	42.783	.002	.033
28	42.131	.003	.011
302	40.885	.004	.008
144	40.633	.004	.002
6	40.450	.004	.001
1	39.812	.005	.000
7	38.878	.007	.000



Observation number	Mahalanobis d-squared	p1	p2
120	38.871	.007	.000
263	38.521	.008	.000
3	38.484	.008	.000
273	38.240	.008	.000
5	38.094	.009	.000
26	37.107	.011	.000
14	36.415	.014	.000
232	36.133	.015	.000
186	36.125	.015	.000
209	35.631	.017	.000
54	35.593	.017	.000
227	35.179	.019	.000
306	34.815	.021	.000
231	34.760	.021	.000
210	34.576	.022	.000
46	34.561	.023	.000
43	34.532	.023	.000
308	34.109	.025	.000
287	33.929	.027	.000
51	33.649	.029	.000
226	33.637	.029	.000
314	33.550	.029	.000
8	33.475	.030	.000
17	33.273	.031	.000
316	32.385	.039	.000
253	32.352	.040	.000
165	32.178	.041	.000
276	31.508	.049	.000
195	31.499	.049	.000
233	31.468	.049	.000
300	31.440	.050	.000
179	31.221	.052	.000
4	31.164	.053	.000
289	31.069	.054	.000
116	30.980	.055	.000
41	30.913	.056	.000
197	30.843	.057	.000
222	30.831	.057	.000
266	30.541	.062	.000
155	30.498	.062	.000
173	30.425	.063	.000
138	30.349	.064	.000
29	30.185	.067	.000



Observation number	Mahalanobis d-squared	p1	p2
228	30.063	.069	.000
25	29.925	.071	.000
121	29.606	.076	.000
163	29.481	.079	.000
9	29.324	.082	.000
206	29.285	.082	.000
198	29.108	.086	.000
181	28.977	.088	.000
281	28.949	.089	.000
229	28.942	.089	.000
177	28.503	.098	.000
158	28.336	.102	.000
118	28.121	.107	.000
261	27.988	.110	.000
160	27.648	.118	.000
291	27.524	.121	.000
178	27.512	.121	.000
59	27.356	.126	.000
56	27.342	.126	.000
299	27.308	.127	.000
136	27.233	.129	.000
285	27.190	.130	.000
284	26.841	.140	.000
238	26.791	.141	.000
258	26.656	.145	.000
44	26.630	.146	.000
193	26.594	.147	.000
13	26.302	.156	.000
187	26.241	.158	.000
252	26.223	.159	.000
268	26.026	.165	.000
108	25.926	.168	.000
30	25.715	.175	.000
312	25.632	.178	.000
283	25.474	.184	.000
42	25.389	.187	.000
15	25.341	.189	.000
156	25.162	.195	.000
269	25.101	.198	.000
57	25.091	.198	.000
224	24.975	.202	.000
55	24.879	.206	.000
24	24.823	.208	.000



Observation number	Mahalanobis d-squared	p1	p2
119	24.523	.220	.000
305	24.309	.229	.001
188	24.104	.238	.003
11	24.096	.238	.002
225	24.004	.242	.002

Model Fit Summary

CMIN

Model	NPAR	CMIN	DF	P	CMIN/DF
Default model	67	720.073	163	.000	4.418
Saturated model	230	.000	0		
Independence model	40	3662.763	190	.000	19.278

RMSEA

Model	RMSEA	LO 90	HI 90	PCLOSE
Default model	.104	.096	.112	.000
Independence model	.240	.233	.247	.000



LAMPIRAN: Hasil Akhir dengan Modifikasi Model

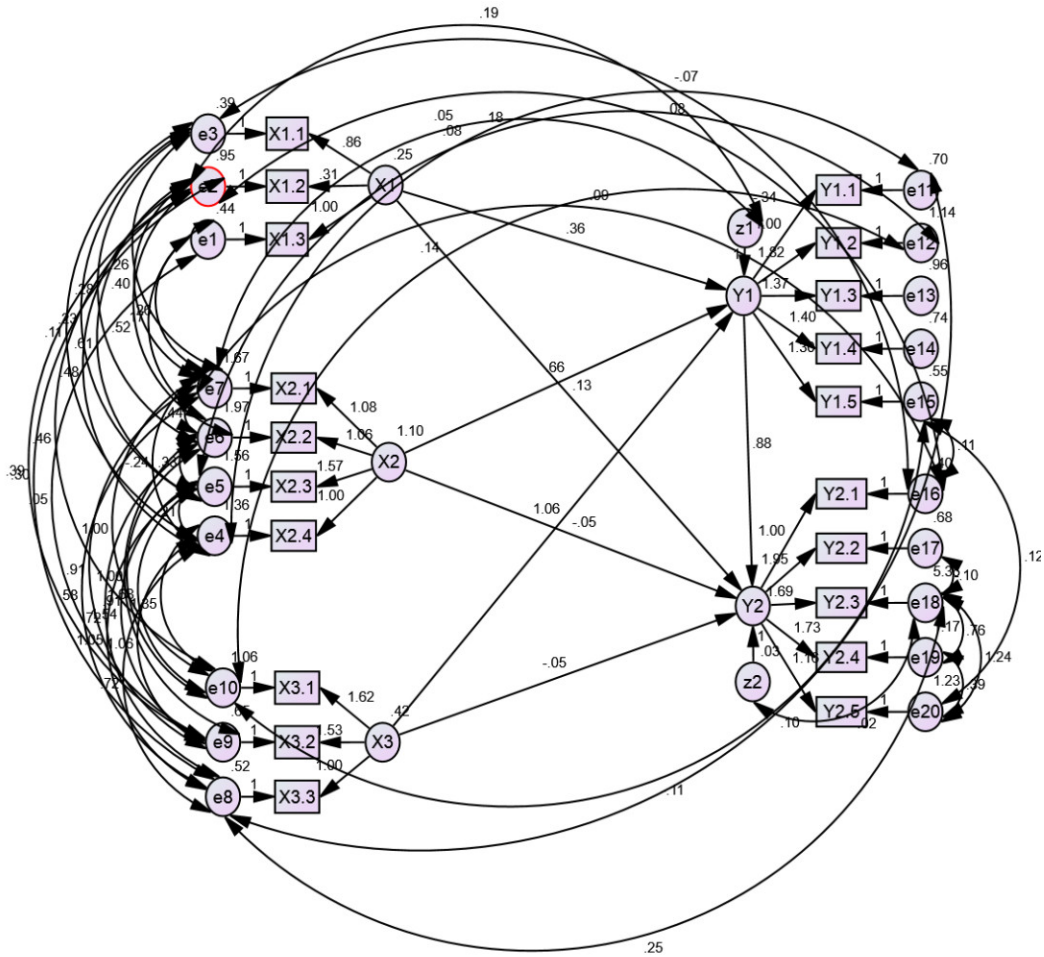

Notes for Model (Default model)

Computation of degrees of freedom (Default model)

Number of distinct sample moments: 210
 Number of distinct parameters to be estimated: 95
 Degrees of freedom (210 - 95): 115

Result (Default model)

Minimum was achieved
 Chi-square = 121.285
 of freedom = 115
 ility level = .326



Variable Summary (Group number 1)

Your model contains the following variables (Group number 1)

Observed, endogenous variables	Unobserved, exogenous variables
X1.3	X1
X1.2	e1
X1.1	e2
X2.4	e3
X2.3	X2
X2.2	e4
X2.1	e5
X3.3	e6
X3.2	e7
X3.1	X3
Y1.1	e8
Y1.2	e9
Y1.3	e10
Y1.4	e11
Y1.5	e12
Y2.1	e13
Y2.2	e14
Y2.3	e15
Y2.4	e16
Y2.5	e17
Unobserved, endogenous variables	e18
Y1	e19
Y2	e20
	z1
	z2

Variable counts (Group number 1)

Number of variables in your model:	47
Number of observed variables:	20
Number of unobserved variables:	27
Number of exogenous variables:	25
Number of endogenous variables:	22



Estimates (Group number 1 - Default model)

Scalar Estimates (Group number 1 - Default model)

Maximum Likelihood Estimates

Regression Weights: (Group number 1 - Default model)

	Estimate	S.E.	C.R.	P	Label
Y1 <--- X1	.359	.118	3.048	.002	par_16
Y1 <--- X2	.664	.083	7.986	***	par_17
Y1 <--- X3	1.063	.103	10.311	***	par_19
Y2 <--- X2	-.050	.034	-1.474	.140	par_18
Y2 <--- X3	-.054	.053	-1.021	.307	par_20
Y2 <--- X1	.131	.074	1.759	.079	par_21
Y2 <--- Y1	.881	.096	9.220	***	par_22
X1.3 <--- X1	1.000				
X1.2 <--- X1	.306	.177	1.723	.085	par_1
X1.1 <--- X1	.865	.246	3.516	***	par_2
X2.4 <--- X2	1.000				
X2.3 <--- X2	1.570	.134	11.738	***	par_3
X2.2 <--- X2	1.065	.121	8.788	***	par_4
X2.1 <--- X2	1.082	.151	7.149	***	par_5
X3.3 <--- X3	1.000				
X3.2 <--- X3	1.529	.135	11.367	***	par_6
X3.1 <--- X3	1.623	.150	10.811	***	par_7
Y1.1 <--- Y1	1.000				
Y1.2 <--- Y1	1.818	.129	14.082	***	par_8
Y1.3 <--- Y1	1.366	.105	13.034	***	par_9
Y1.4 <--- Y1	1.400	.101	13.840	***	par_10
Y1.5 <--- Y1	1.303	.092	14.120	***	par_11
Y2.1 <--- Y2	1.000				
Y2.2 <--- Y2	1.952	.124	15.686	***	par_12
Y2.3 <--- Y2	1.687	.213	7.917	***	par_13
Y2.4 <--- Y2	1.733	.128	13.507	***	par_14
Y2.5 <--- Y2	1.160	.110	10.580	***	par_15



Standardized Regression Weights: (Group number 1 - Default model)

	Estimate
Y1 <--- X1	.219
Y1 <--- X2	.856
Y1 <--- X3	.852
Y2 <--- X2	-.077
Y2 <--- X3	-.051
Y2 <--- X1	.095
Y2 <--- Y1	1.050
X1.3 <--- X1	.598
X1.2 <--- X1	.154
X1.1 <--- X1	.566
X2.4 <--- X2	.669
X2.3 <--- X2	.796
X2.2 <--- X2	.622
X2.1 <--- X2	.659
X3.3 <--- X3	.670
X3.2 <--- X3	.777
X3.1 <--- X3	.717
Y1.1 <--- Y1	.697
Y1.2 <--- Y1	.810
Y1.3 <--- Y1	.750
Y1.4 <--- Y1	.798
Y1.5 <--- Y1	.819
Y2.1 <--- Y2	.734
Y2.2 <--- Y2	.850
Y2.3 <--- Y2	.443
Y2.4 <--- Y2	.738
Y2.5 <--- Y2	.582



Intercepts: (Group number 1 - Default model)

	Estimate	S.E.	C.R.	P	Label
X1.3	9.168	.047	196.538	***	par_71
X1.2	7.789	.055	140.889	***	par_72
X1.1	9.060	.043	212.679	***	par_73
X2.4	16.623	.088	188.924	***	par_74
X2.3	24.827	.116	214.034	***	par_75
X2.2	20.580	.101	204.305	***	par_76
X2.1	21.075	.097	218.257	***	par_77
X3.3	8.283	.055	151.781	***	par_78
X3.2	12.701	.072	176.371	***	par_79
X3.1	12.245	.083	147.775	***	par_80
Y1.1	12.753	.065	194.714	***	par_81
Y1.2	20.607	.102	201.091	***	par_82
Y1.3	16.849	.083	202.532	***	par_83
Y1.4	12.519	.080	156.279	***	par_84
Y1.5	12.547	.073	172.714	***	par_85
Y2.1	8.374	.052	160.403	***	par_86
Y2.2	17.160	.088	194.827	***	par_87
Y2.3	13.191	.146	90.296	***	par_88
Y2.4	16.972	.090	188.536	***	par_89
Y2.5	12.664	.076	165.549	***	par_90



Squared Multiple Correlations: (Group number 1 - Default model)

	Estimate
Y1	1.507
Y2	.934
Y2.5	.338
Y2.4	.545
Y2.3	.207
Y2.2	.722
Y2.1	.539
Y1.5	.671
Y1.4	.637
Y1.3	.563
Y1.2	.656
Y1.1	.486
X3.1	.514
X3.2	.604
X3.3	.450
X2.1	.435
X2.2	.387
X2.3	.634
X2.4	.447
X1.1	.321
X1.2	.024
X1.3	.358



Total Effects (Group number 1 - Default model)

	X2	X1	X3	Y1	Y2
Y1	.664	.359	1.063	.000	.000
Y2	.536	.447	.884	.881	.000
Y2.5	.622	.519	1.026	1.023	1.160
Y2.4	.928	.775	1.532	1.528	1.733
Y2.3	.904	.754	1.491	1.487	1.687
Y2.2	1.046	.873	1.725	1.721	1.952
Y2.1	.536	.447	.884	.881	1.000
Y1.5	.866	.468	1.386	1.303	.000
Y1.4	.930	.502	1.489	1.400	.000
Y1.3	.908	.490	1.453	1.366	.000
Y1.2	1.208	.652	1.933	1.818	.000
Y1.1	.664	.359	1.063	1.000	.000
X3.1	.000	.000	1.623	.000	.000
X3.2	.000	.000	1.529	.000	.000
X3.3	.000	.000	1.000	.000	.000
X2.1	1.082	.000	.000	.000	.000
X2.2	1.065	.000	.000	.000	.000
X2.3	1.570	.000	.000	.000	.000
X2.4	1.000	.000	.000	.000	.000
X1.1	.000	.865	.000	.000	.000
X1.2	.000	.306	.000	.000	.000
X1.3	.000	1.000	.000	.000	.000



Standardized Total Effects (Group number 1 - Default model)

	X2	X1	X3	Y1	Y2
Y1	.856	.219	.852	.000	.000
Y2	.822	.325	.844	1.050	.000
Y2.5	.478	.189	.491	.611	.582
Y2.4	.607	.240	.623	.775	.738
Y2.3	.364	.144	.373	.465	.443
Y2.2	.698	.276	.717	.892	.850
Y2.1	.604	.239	.619	.771	.734
Y1.5	.701	.180	.698	.819	.000
Y1.4	.683	.175	.680	.798	.000
Y1.3	.642	.164	.639	.750	.000
Y1.2	.693	.178	.690	.810	.000
Y1.1	.597	.153	.594	.697	.000
X3.1	.000	.000	.717	.000	.000
X3.2	.000	.000	.777	.000	.000
X3.3	.000	.000	.670	.000	.000
X2.1	.659	.000	.000	.000	.000
X2.2	.622	.000	.000	.000	.000
X2.3	.796	.000	.000	.000	.000
X2.4	.669	.000	.000	.000	.000
X1.1	.000	.566	.000	.000	.000
X1.2	.000	.154	.000	.000	.000
X1.3	.000	.598	.000	.000	.000



Direct Effects (Group number 1 - Default model)

	X2	X1	X3	Y1	Y2
Y1	.664	.359	1.063	.000	.000
Y2	-.050	.131	-.054	.881	.000
Y2.5	.000	.000	.000	.000	1.160
Y2.4	.000	.000	.000	.000	1.733
Y2.3	.000	.000	.000	.000	1.687
Y2.2	.000	.000	.000	.000	1.952
Y2.1	.000	.000	.000	.000	1.000
Y1.5	.000	.000	.000	1.303	.000
Y1.4	.000	.000	.000	1.400	.000
Y1.3	.000	.000	.000	1.366	.000
Y1.2	.000	.000	.000	1.818	.000
Y1.1	.000	.000	.000	1.000	.000
X3.1	.000	.000	1.623	.000	.000
X3.2	.000	.000	1.529	.000	.000
X3.3	.000	.000	1.000	.000	.000
X2.1	1.082	.000	.000	.000	.000
X2.2	1.065	.000	.000	.000	.000
X2.3	1.570	.000	.000	.000	.000
X2.4	1.000	.000	.000	.000	.000
X1.1	.000	.865	.000	.000	.000
X1.2	.000	.306	.000	.000	.000
X1.3	.000	1.000	.000	.000	.000



Standardized Direct Effects (Group number 1 - Default model)

	X2	X1	X3	Y1	Y2
Y1	.856	.219	.852	.000	.000
Y2	-.077	.095	-.051	1.050	.000
Y2.5	.000	.000	.000	.000	.582
Y2.4	.000	.000	.000	.000	.738
Y2.3	.000	.000	.000	.000	.443
Y2.2	.000	.000	.000	.000	.850
Y2.1	.000	.000	.000	.000	.734
Y1.5	.000	.000	.000	.819	.000
Y1.4	.000	.000	.000	.798	.000
Y1.3	.000	.000	.000	.750	.000
Y1.2	.000	.000	.000	.810	.000
Y1.1	.000	.000	.000	.697	.000
X3.1	.000	.000	.717	.000	.000
X3.2	.000	.000	.777	.000	.000
X3.3	.000	.000	.670	.000	.000
X2.1	.659	.000	.000	.000	.000
X2.2	.622	.000	.000	.000	.000
X2.3	.796	.000	.000	.000	.000
X2.4	.669	.000	.000	.000	.000
X1.1	.000	.566	.000	.000	.000
X1.2	.000	.154	.000	.000	.000
X1.3	.000	.598	.000	.000	.000



Indirect Effects (Group number 1 - Default model)

	X2	X1	X3	Y1	Y2
Y1	.000	.000	.000	.000	.000
Y2	.586	.316	.937	.000	.000
Y2.5	.622	.519	1.026	1.023	.000
Y2.4	.928	.775	1.532	1.528	.000
Y2.3	.904	.754	1.491	1.487	.000
Y2.2	1.046	.873	1.725	1.721	.000
Y2.1	.536	.447	.884	.881	.000
Y1.5	.866	.468	1.386	.000	.000
Y1.4	.930	.502	1.489	.000	.000
Y1.3	.908	.490	1.453	.000	.000
Y1.2	1.208	.652	1.933	.000	.000
Y1.1	.664	.359	1.063	.000	.000
X3.1	.000	.000	.000	.000	.000
X3.2	.000	.000	.000	.000	.000
X3.3	.000	.000	.000	.000	.000
X2.1	.000	.000	.000	.000	.000
X2.2	.000	.000	.000	.000	.000
X2.3	.000	.000	.000	.000	.000
X2.4	.000	.000	.000	.000	.000
X1.1	.000	.000	.000	.000	.000
X1.2	.000	.000	.000	.000	.000
X1.3	.000	.000	.000	.000	.000



Standardized Indirect Effects (Group number 1 - Default model)

	X2	X1	X3	Y1	Y2
Y1	.000	.000	.000	.000	.000
Y2	.899	.230	.895	.000	.000
Y2.5	.478	.189	.491	.611	.000
Y2.4	.607	.240	.623	.775	.000
Y2.3	.364	.144	.373	.465	.000
Y2.2	.698	.276	.717	.892	.000
Y2.1	.604	.239	.619	.771	.000
Y1.5	.701	.180	.698	.000	.000
Y1.4	.683	.175	.680	.000	.000
Y1.3	.642	.164	.639	.000	.000
Y1.2	.693	.178	.690	.000	.000
Y1.1	.597	.153	.594	.000	.000
X3.1	.000	.000	.000	.000	.000
X3.2	.000	.000	.000	.000	.000
X3.3	.000	.000	.000	.000	.000
X2.1	.000	.000	.000	.000	.000
X2.2	.000	.000	.000	.000	.000
X2.3	.000	.000	.000	.000	.000
X2.4	.000	.000	.000	.000	.000
X1.1	.000	.000	.000	.000	.000
X1.2	.000	.000	.000	.000	.000
X1.3	.000	.000	.000	.000	.000



Model Fit Summary

CMIN

Model	NPAR	CMIN	DF	P	CMIN/DF
Default model	95	121.285	115	.326	1.055
Saturated model	210	.000	0		
Independence model	20	3662.763	190	.000	19.278

RMR, GFI

Model	RMR	GFI	AGFI	PGFI
Default model	.142	.965	.936	.528
Saturated model	.000	1.000		
Independence model	1.043	.205	.121	.185

Baseline Comparisons

Model	NFI Delta1	RFI rho1	IFI Delta2	TLI rho2	CFI
Default model	.967	.945	.998	.997	.998
Saturated model	1.000		1.000		1.000
Independence model	.000	.000	.000	.000	.000

Parsimony-Adjusted Measures

Model	PRATIO	PNFI	PCFI
Default model	.605	.585	.604
Saturated model	.000	.000	.000
Independence model	1.000	.000	.000

NCP

Model	NCP	LO 90	HI 90
Default model	6.285	.000	36.818
Saturated model	.000	.000	.000
Independence model	3472.763	3279.851	3672.985

FMIN

Model	FMIN	F0	LO 90	HI 90
Default model	.383	.020	.000	.116
Saturated model	.000	.000	.000	.000
Independence model	11.554	10.955	10.347	11.587



RMSEA

Model	RMSEA	LO 90	HI 90	PCLOSE
Default model	.013	.000	.032	1.000
Independence model	.240	.233	.247	.000

AIC

Model	AIC	BCC	BIC	CAIC
Default model	311.285	324.764	668.679	763.679
Saturated model	420.000	449.797	1210.031	1420.031
Independence model	3702.763	3705.601	3778.004	3798.004

ECVI

Model	ECVI	LO 90	HI 90	MECVI
Default model	.982	.962	1.078	1.024
Saturated model	1.325	1.325	1.325	1.419
Independence model	11.681	11.072	12.312	11.690

HOELTER

Model	HOELTER .05	HOELTER .01
Default model	369	401
Independence model	20	21



LAMPIRAN: HASIL UJI SOBEL TEST

			Estimate	S.E.	C.R.	P	Label
Y1	<---	X1	.359	.118	3.048	.002	par_16
Y1	<---	X2	.664	.083	7.986	***	par_17
Y1	<---	X3	1.063	.103	10.311	***	par_19
Y2	<---	X2	-.050	.034	-1.474	.140	par_18
Y2	<---	X3	-.054	.053	-1.021	.307	par_20
Y2	<---	X1	.131	.074	1.759	.079	par_21
Y2	<---	Y1	.881	.096	9.220	***	par_22
X1.3	<---	X1	1.000				
X1.2	<---	X1	.306	.177	1.723	.085	par_1
X1.1	<---	X1	.865	.246	3.516	***	par_2
X2.4	<---	X2	1.000				
X2.3	<---	X2	1.570	.134	11.738	***	par_3
X2.2	<---	X2	1.065	.121	8.788	***	par_4

Input:		Test statistic:	Std. Error:	p-value:
a	0.359	Sobel test: 2.88781676	0.10952184	0.00387926
b	0.881	Aroian test: 2.87249259	0.11010612	0.00407248
s _a	0.118	Goodman test: 2.90338883	0.10893443	0.00369148
s _b	0.096	Reset all	Calculate	

Input:		Test statistic:	Std. Error:	p-value:
a	0.664	Sobel test: 6.03035571	0.09700655	0
b	0.881	Aroian test: 6.01011533	0.09733324	0
s _a	0.083	Goodman test: 6.05080197	0.09667875	0
s _b	0.096	Reset all	Calculate	

Input:		Test statistic:	Std. Error:	p-value:
a	1.063	Sobel test: 6.85791404	0.136558	0
b	0.881	Aroian test: 6.84000629	0.13691552	0
s _a	0.103	Goodman test: 6.87596318	0.13619954	0
s _b	0.096	Reset all	Calculate	

