

DAFTAR PUSTAKA

- Achmad, T. (2012). Dewan Komisaris Dan Transparansi: Teori Keagenan Atau Teori Stewardship? *Jurnal Keuangan dan Perbankan*, 16(1), 1–12.
- Adeyemi, F., & Olarewaju, O. (2019). Economic development models of emerging countries INTERNAL CONTROL SYSTEM AND FINANCIAL ACCOUNTABILITY: AN INVESTIGATION OF NIGERIAN SOUTH-WESTERN PUBLIC SECTOR *. *Economic development models of emerging countries*, 245–261.
- Agus Suma Arta, I. M., & Rasmini, N. K. (2019). Pengaruh Kejelasan Sasaran Anggaran, Sistem Pelaporan dan Partisipasi Masyarakat Pada Akuntabilitas Pengelolaan Dana Desa. *E-Jurnal Akuntansi*, 26, 709. <https://doi.org/10.24843/eja.2019.v26.i01.p26>
- Agustin, N. (2019). Pengaruh Perencanaan Anggaran dan Pengendalian Intern terhadap Akuntabilitas Publik pada Pemerintah Daerah Provinsi Riau. *Akuntansi dan Manajemen*, 14(2), 109–118. <https://doi.org/10.30630/jam.v14i2.49>
- Alvin, A. A., Randal, J. E., Mark, S. B., & Amir, A. J. (2011). *Audit dan Jasa Assurance: Pendekatan Terpadu (Adaptasi Indonesia)*. Penerbit Salemba Empat.
- Aminah, & Chindy, F. (2016). Hubungan Pengendalian Internal Dan Kompensasi Dengan Kecurangan Akuntansi (Studi Pada BPR di Provinsi Lampung). *Jurnal Akuntansi dan Keuangan*, 7(1), 1–13.
- Anessi-Pessina, E., Barbera, C., Langella, C., Manes-Rossi, F., Sancino, A., Sicilia, M., & Steccolini, I. (2020). Reconsidering public budgeting after the COVID-19 outbreak: key lessons and future challenges. *Journal of Public Budgeting, Accounting and Financial Management*, 32(5), 957–965. <https://doi.org/10.1108/JPBAFM-07-2020-0115>
- Anthony, Robert N dan Vijay Govindarajan. 2008. *Sistem Pengendalian Manajemen*. Salemba Empat. Jakarta
- Arifin, A., & Pagalung, G. (2018). Empirical Study of the Effect of Participation of Budget in Managerial Performance. *International Journal of Advanced Engineering, Management and Science*, 4(9), 645–651. <https://doi.org/10.22161/ijaems.4.9.1>
- Asri Eka Ratih, Nurhasah. S. (2018). Pengaruh Kompetensi Aparatur Desa Dan Peran Serta Bpd Terhadap Kualitas Laporan Keuangan Desa Di Teluk Sebong Dan Teluk Bintan. *Jurnal Ilmiah Akuntansi dan Finansial Indonesia*, 2(1), 65–78. <https://doi.org/10.31629/jiafi.v2i1.1278>

- Astuti, T. P., & Yulianto, Y. (2016). Good Governance Pengelolaan Keuangan Desa Menyongsong Berlakunya Undang-Undang No. 6 Tahun 2014. *Berkala Akuntansi dan Keuangan Indonesia*, 1(1), 1–14. <https://doi.org/10.20473/baki.v1i1.1694>
- Aulia, P. (2018). Pengaruh Kompetensi Aparat Pengelolaan Dana Desa, Komitmen Organisasi Pemerintah Desa, Pemanfaatan Teknologi Informasi, dan Partisipasi Masyarakat Terhadap Akuntabilitas Pengelolaan Dana Desa di Kabupaten 50 Kota. *Jurnal Online Mahasiswa Feb*, 1(1), 1–15. <https://ejournal.unsrat.ac.id/index.php/iaj/article/view/29261>
- Aziz, M. A. A., Rahman, H. A., Alam, M. M., & Said, J. (2015). Enhancement of the Accountability of Public Sectors through Integrity System, Internal Control System and Leadership Practices: A Review Study. *Procedia Economics and Finance*, 28(15), 163–169. [https://doi.org/10.1016/s2212-5671\(15\)01096-5](https://doi.org/10.1016/s2212-5671(15)01096-5)
- Bastian, I. (2007). *Sistem Akuntansi Sektor Publik (Kedua)*. Salemba Empat.
- Bastian, Indra. 2006. *Akuntansi Sektor Publik, Suatu Pengantar*. Erlangga: Jakarta.
- Belkaoui, A. R. (2012). *Teori Akuntansi*. Salemba Empat.
- Bergman, & Lane. (1990). Public policy in a principal-agent framework. *Journal of Theoretical Politics*, 2(3), 339–352.
- Bouckova, M. (2015). Management Accounting and Agency Theory. *Procedia Economics and Finance*, 25(15), 5–13. [https://doi.org/https://doi.org/10.1016/s2212-5671\(15\)00707-8](https://doi.org/https://doi.org/10.1016/s2212-5671(15)00707-8)
- BPS, B. P. S. (2018). *Rincian Alokasi Transfer Ke Daerah dan dana Desa Provinsi/Kabupaten/Kota Dalam APBN T.A. 2018*. 2018, 1–10.
- Brownell, P. 1982. "Participation in The Budgeting Process. When it Works and When Doesn't". *Journal Accounting Literature*, Vol 1, pp 124-53
- Budi Rihardjo, I. (2006). PENGARUH DESENTRALISASI DAN KOMITMEN ORGANISASIONAL TERHADAP HUBUNGAN ANTARA PENGANGGARAN PARTISIPATIF DAN KINERJA MANAJERIAL. *EKUITAS (Jurnal Ekonomi dan Keuangan)*, 13(55), 326–348.
- Budiati, Y., Sugiyanto, E. K., & Niati, A. (2020). Pengaruh Gcg Terhadap Kinerja Pengelolaan Dana Desa Dengan Moderasi Sistem Pengendalian Internal. *EKUITAS (Jurnal Ekonomi dan Keuangan)*, 3(4), 425–444. <https://doi.org/10.24034/j25485024.y2019.v3.i4.4127>
- Caers, R., Cindy, D. B., Marc, J., Sara, D. G., Catherine, S., & Roland, P. (2006). Principal-Agent Relationships on the Stewardship-Agency Axis", *Nonprofit Management and Leadership*. 17, 1.

- Candrakusuma, D. A., & Jatmiko, B. (2017). Dampak Komitmen Organisasi, Sistem Pengendalian Intern Pemerintah, Akuntabilitas Publik, Partisipasi Anggaran Dan Kejelasan Sasaran Anggaran Terhadap Kinerja Manajerial. *Jurnal Bisnis dan Ekonomi (JBE)*, 24(1), 87–93.
- Chodijah, S., & Hidayah, N. (2018). PENGARUH PEMANFAATAN TEKNOLOGI INFORMASI DAN SISTEM PENGENDALIAN INTERNAL TERHADAP KUALITAS PELAPORAN KEUANGAN PEMERINTAH DAERAH (Studi Kasus SKPD Provinsi DKI Jakarta). *TEKUN: Jurnal Telaah Akuntansi dan Bisnis*, 9(1), 34–48. <https://doi.org/10.22441/tekun.v8i1.2595>
- Chong, V. K., & Chong, K. M. (2002). Budget Goal Commitment and Informational Effects of Budget Participation on Performance: A Structural Equation Modeling Approach. *Behavioral Research in Accounting*, 14(1), 65–86. <https://doi.org/10.2308/bria.2002.14.1.65>
- Cornelius, K., & Caroline, A. (2017). Effect Of Internal Control Systems On Financial Management In Baringo County Government, Kenya. *Journal of Economics Finance and Accounting*, 3(1).
- David, M., & Van, S. (2006). Agents or Stewards: Using Theory to Understand the Government-Nonprofit Social Service Contracting Relationship. *Journal of Public Administration Research and Theory*, 17.
- Dewi, R. A., Ramadhanti, W., & Wiratno, A. (2014). FAKTOR-FAKTOR YANG BERPENGARUH TERHADAP KINERJA KEUANGAN PEMERINTAH DESA PASCA PENERAPAN UNDANG-. 311–327.
- Dewi, S., & Indo, D. (2021). D, Sari Faktor-faktor yang Mempengaruhi Budgetary Slack dengan Gaya Kepemimpinan sebagai Moderasi. *Jesya (Jurnal Ekonomi & Ekonomi Syariah)*, 4(2), 775–783. <https://doi.org/10.36778/jesya.v4i2.415>
- Ditjen Bina Pemerintahan Desa, 2021. (2021). *Pelaporan dan Keuangan Desa*.
- Djalil, M. A., Saputra, M., Kuala, U. S., & Aceh, B. (2021). Ermida, Muslim A. Djalil* and Mulia Saputra Magister of Accountancy, Faculty of Economics and Business, Universitas Syiah Kuala, Banda Aceh, Indonesia <http://doi.org/10.35409/IJBMER.2021.3327>. 4(06), 124–135.
- Djanegara, M. S. (2017). Pengaruh Kualitas Audit Terhadap Kualitas Laporan Keuangan. *Jurnal Akuntansi*, XXI(03), 461–483.
- DJPK Kemenkeu. (2019). *Rincian dana Desa MENurut Kabupaten/Kota T.A 2019*.
- DJPK Kemenkeu. (2020). *Dana Desa 2020* (hal. 13).
- DJPK Kemenkeu. (2021). *Laporan Rincian Alokasi Dana Desa Menurut Provinsi/Kabupaten/Kota 2021* (hal. 11).

- Donaldson, L., & Davis, J. H. (1991). Stewardship theory or agency theory: CEO governance and shareholder returns. *Australian Journal of Management*, 16, 49–64.
- Ernawilis; Nasir, Azwir; Kurnia, P. (2015). PENGARUH AKUNTABILITAS PUBLIK, PARTISIPASI PENYUSUNAN ANGGARAN, KEJELASAN SASARAN ANGGARAN DAN STRUKTUR DESENTRALISASI TERHADAP KINERJA APARAT PEMERINTAH DAERAH SKPD DENGAN PENGAWASAN INTERNAL SEBAGAI VARIABEL PEMODERASI KAB. KUANTAN SINGINGI. *Jurnal Online Mahasiswa Fakultas Ekonomi Universitas Riau*, 2(2), 12–26.
- Fakhry, Syarifuddin, & Said, D. (2014). Budget Process Pemerintahan Daerah: Menelisik Nilai Kemandaran Atas Perilaku Aktor Anggaran. *Jurnal Analisis*, 3(2), 189–194.
- Febriana, L., Wardayati, S. M., & Prasetyo, W. (2017). The Effect of Internal Control Factors on the Accountability of the Auditor at the Inspectorate of Jombang District. *Jurnal Dinamika Akuntansi*, 9(2), 166–175. <https://doi.org/10.15294/jda.v9i2.9308>
- Fitri, D., Basri, H., & Abdullah, S. (2017). Pengaruh Penganggaran, Penatausahaan, Kualitas Pelaporan Terhadap Kinerja Pengelolaan Keuangan Daerah Dengan Teknologi Informasi Sebagai Pemoderasi (Studi pada Satuan Kerja Perangkat Kota Pemerintah Kota Sabang). *Jurnal Megister Akuntansi*, 6(2), 41–51.
- Ghapanchi, A. H., Khani Amirabadi, M., & Javadi Moghaddam, M. R. (2014). The Impact of Budget Participation on Control System Design. *Procedia - Social and Behavioral Sciences*, 109, 941-945.
- Ghozali, I., & Achmad, T. (2017). the Effect of Internal Audit and Internal Control System on Public Accountability : the Emperical Study. *International Journal of Civil Engineering and Technology (IJCIET)*, 8(September), 157–166.
- Glinkowska, B., & Kaczmarek, B. (2016). Classical And Modern Concepts of Corporate Governance (Stewardship Theory and Agency Theory). *Management*, 19(2), 84–92. <https://doi.org/https://doi.org/10.1515/manment-2015-0015>
- Hair, J. ., Anderson, R. ., Tatham, R. ., & Black, W. . (2008). *ultivariate Data Analisis* (7en ed.). Prentice Hall Publisher, Upper Saddle River, New Jersey.
- Hardikasari, E., & Sugeng, P. (2011). *Pengaruh Penerapan Corporate Governance Terhadap Kinerja Keuangan Pada Industri Perbankan Yang Terdaftar Di Bursa Efek Indonesia (BEI) Tahun 2006-2008*.

- Hernanda, L. T., & Setiyawati, H. (2020). Pengaruh Komitmen Organisasi, Pelaksanaan Anggaran Dan Implementasi Sistem Informasi Akuntansi terhadap Kualitas Laporan Keuangan (Survei pada Pemerintah Daerah Kota Bogor). *Jurnal Akuntansi dan Keuangan Islam*, 1(2). <https://doi.org/https://doi.org/10.24042/al-mal.v1i2.5909>
- Heski, P., Purwanti, D. T., & Fidayati, A. (2017). Partisipasi Penyusunan Anggaran, Kejelasan Sasaran Anggaran, Akuntabilitas Publik, dan Struktur Desentralisasi terhadap Kinerja Manajerial. *Jurnal Analisis Bisnis Ekonomi*, 15(2), 117–125. <https://doi.org/10.31603/bisnisekonomi.v15i2.1837>
- Hidayah, N., & Wijayanti, I. (2017). Akuntabilitas Pengelolaan Dana Desa (Dd) Studi Kasus Pada Desa Wonodadi Kecamatan Ngrayun Kabupaten Ponorogo. *Jurnal AKSI (Akuntansi dan Sistem Informasi)*, 1(2), 1–7. <https://doi.org/10.32486/aksi.v1i2.114>
- Hidayat, R. (2021). *Pengaruh Motivasi , Kompetensi dan Disiplin Kerja Terhadap Kinerja*. 5(1), 16–23.
- Hirsch, P., S. Michaels, & R. Friedman. (1987). Clean Models Versus Dirty Hands: Why Economics Is Different from Sociology. *Theory and Society*, 16(3), 317–336.
- Indraswari, N. E., & Rahayu, Y. (2021). Pengaruh Kompetensi Pemerintah Desa , Partisipasi Masyarakat dan Pemanfaatan Teknologi Informasi terhadap Akuntabilitas Pengelolaan Dana Desa. *Jurnal Ilmu dan Riset Akuntansi*, 10(4), 1–15.
- Ironkwe, U. (2015). The Impact Of Internal Controls On Financial Management : A Case Of Production Companies In Nigeria. *International Journal of Economics, Commerce and Management United Kingdom*, 3(12).
- Ishola, S. A., & Abikoye, O. A. (2015). Effect Of Internal Control System In Nigeria Public Sectors: A Case Study Of Nigeria National Petroleum Corporation. *International Journal of Economics, Commerce and Management United Kingdom*, 3(6).
- Jensen, M. C., & Meckling, W. H. (1976). Theory of The Firm: Managerial Behavior, Agency Cost and Ownership Structure. *Journal of Financial Economics*, 3(1), 305–360.
- John, W., Dichaut, & Kevin, A. M. (1997). The Behavioral Foundations of Stewardship Accounting and a Proposed Program of Research: What is Accountability? *Behavioral Research in Accounting*, 9(3).
- Johnson, E. N., Lennox, C. S., & Yeo, K. T. (2003). The Impact of Participation in the Budgeting Process on Managerial Accounting Control Systems. *Behavioral Research in Accounting*, 15, 141-170.

- Jorge, S. ., MouraeSá, P., Pattaro, A. F., & Lourenço, R. P. (2011). *Local government financial transparency in Portugal and Italy: A comparative exploratory study on its determinants*.
- Kamilah, F., Taufik, T., & Darlis, E. (2013). PENGARUH PARTISIPASI ANGGARAN TERHADAP KINERJA MANAJERIAL DENGAN KOMITMEN ORGANISASI DAN GAYA KEPEMIMPINAN SEBAGAI VARIABEL MODERATING (Studi Empiris Pada Rumah Sakit Di Pekanbaru). *Sorot*, 8(2), 105. <https://doi.org/10.31258/sorot.8.2.2354>
- Karyadi, M. (2019). Pengaruh sistem pengendalian intern, pemanfaatan teknologi informasi dan kompetensi sumber daya manusia terhadap akuntabilitas keuangan desa (studi di Kecamatan Aikmel dan Kecamatan Lenek tahun 2018). *Journal Ilmiah Rinjani*, 7(2), 33–46.
- Kementrian Dalam Negeri Republik Indonesia. (2014). Peraturan Menteri Dalam Negeri Nomor 113 Tahun 2014 tentang Pengelolaan Keuangan Desa. *Peraturan.Bpk.Go.Id*, 51(1), 51. <https://peraturan.bpk.go.id/Home/Details/111736/permendagri-no-113-tahun-2014>
- Kenis, I. 1979. "Effect of Goal Characteristics on Managerial Attitudes and Perfomance". *The Accounting Review*, Vol. 54, pp. 702-721.
- Khoiriah, K., & Wiratno, A. (2017). Pengaruh Partisipasi Anggaran, Komitmen Organisasi, Kecukupan Anggaran, dan Job Relevan Information Terhadap Kinerja Manajerial. *Jurnal Riset Akuntansi & Perpajakan (JRAP)*, 4(02), 222–232. <https://doi.org/10.35838/jrap.v4i02.164>
- King, M., Setiyawati, H., & Mappanyuki, R. (2019). The Effect Of The Implementation Of Government Internal Control Towards Auditor Opinion Using The Application Of Government Accounting. *International Conference on Rural Development and Entrepreneurship*, 5(1).
- Kuncoro, M. (2003). *Metode Riset untuk Bisnis & Ekonomi*. Erlangga.
- Kusumastuti, D. (2001). *MANAJEMEN SISTEM PENGEMBANGAN SUMBER DAYA DOSEN SEBAGAI PENJAMIN MUTU DI PERGURUAN TINGGI*. <http://repository.upi.edu>
- Kwarteng, A. (2018). 기사 (Article) 와 안내문 (Information) [. *The Eletronic Library*, 34(1), 1–5. <https://doi.org/https://doi.org/10.1108/AJEMS-03-2017-0056>
- Lee, T., & Mary, S. (1995). Competence and Independence: The Congenial Twins Of Auditing? *Business Finance and Accounting*, 22(8), 1169–1177.

- Lili Indarto, Stefani . Dyah Ayu, S. (2011). PENGARUH PARTISIPASI DALAM PENYUSUNAN ANGGARAN TERHADAP KINERJA MANAJERIAL PERUSAHAAN MELALUI KECUKUPAN ANGGARAN, KOMITMEN ORGANISASI, KOMITMEN TUJUAN ANGGARAN, DAN JOB RELEVANT INFORMATION (JRI). *SERI KAJIAN ILMIAH*, 14(1).
- Mada, S., Kalangi, L., & Gamaliel, H. (2017). Pengaruh Kompetensi Aparat Pengelola Dana Desa, Komitmen Organisasi Pemerintah Desa, dan Partisipasi Masyarakat Terhadap Akuntabilitas Pengelolaan Dana Desa Di Kabupaten Gorontalo. *Jurnal Riset Akuntansi Dan Auditing "Goodwill,"* 8(2), 106–115. <https://doi.org/10.35800/jjs.v8i2.17199>
- Maharani, G. (2021). *Pengaruh Kompetensi Aparatur Desa dan Pemanfaatan Teknologi Informasi terhadap Akuntabilitas Pengelolaan Dana Desa dengan Sistem Pengendalian Internal sebagai Variabel Intervening (Studi Empiris pada Desa di Kecamatan Kajoran Kabupaten Magelang)*.
- Mahsun, M. (2019). Konsep Dasar Penganggaran. *Penganggaran Sektor Publik*, 256.
- Makalalag, A. J., Nangoi, G. B., & Karamoy, H. (2017). *Akuntabilitas Pengelolaan Dana Desa di Kecamatan Kotamobagu Selatan Kota Kotamobagu*. 149–158. http://eprints.undip.ac.id/24290/1/Agus_Subroto.pdf
- Mardiasmo. (2018). *Akuntansi Sektor Publik*. Andi.
- Medianti, L. (2018). Pengaruh Partisipasi Masyarakat, Kompetensi Aparat dan Sistem Pengendalian Intern Terhadap Akuntabilitas Pengelolaan Dana Desa Sebagai Variable Pemodesari (Studi Pada Pemerintah Desa di Kecamatan Bayat). *Jom Feb*, 1(Dd).
- Meutia, I., & Liliana. (2017). *Pengelolaan Keuangan Dana Desa*.
- Milani, K. W. 1975. "The Relationship of Participation in Budget-Setting to Industrial Supervisor Performance and Attitudes: A Field Study", *The Accounting Review*. Vol April. pp. 274-284
- Morgan, D., Bacon, K. G., Bunch, R., Cameron, C., & Deis, R. (1996). What MiddleMmanagers Do In Local Government: Stewardship of The Public Trust And Limits Of Reinventing Government. *Public Administration Review*, 56(4).
- Mukaromah, U., & Wahyu, P. 2018. Pengaruh Partisipasi Anggaran, Desentralisasi, Akuntabilitas Publik Terhadap Kinerja Manajerial Skpd Dengan Pengawasan Internal Sebagai Variabel Moderasi (Studi Pada Satuan Kerja Perangkat Daerah Karanganyar). Doctoral Dissertation, lain Surakarta.
- Mulyadi. (2014). *Auditing*. Salemba Empat.

- Musdalifah. (2019). *Pengaruh Perencanaan Anggaran, Sistem Informasi Keuangan daerah dan Standar Akuntansi Pemerintah terhadap Kualitas Laporan Keuangan Pemerintah Daerah pada Pemerintah Kabupaten Enrekang* (Nomor April).
- Mustofa. (2017). Peningkatan Kinerja Karyawan Perbankan Syariah di Gorontalo (Studi atas Budaya Organisasi , Kompetensi dan Motivasi). *Al-Ulum*, 17(1), 120–142.
- Nagara, D. S., & Mulyani, S. (2019). KUALITAS LAPORAN KEUANGAN PEMERINTAH DAERAH DIUKUR MENGGUNAKAN PARAMETER NiCE. *Jurnal SIKAP (Sistem Informasi, Keuangan, Auditing Dan Perpajakan)*, 3(2), 135. <https://doi.org/10.32897/jsikap.v3i2.152>
- Novita, I., Taufik, T., & Agustiningsih, M. (2020). the Effect of Good Governance and Human Resource Competency of Village Fund Management (Empirical Study of Villages in Tambang District, Kampar District and Bangkinang District). *Jurnal Ilmiah Akuntansi*, 4(1), 80–91. <http://www.ejournal.pelitaindonesia.ac.id/ojs32/index.php/BILANCIA/index>
- Panjaitan, I., & Shopiana, S. (2017). Pengaruh Karakteristik Tujuan Anggaran Dan Penerapan Sistem Informasi Akuntansi Terhadap Kinerja Aparat Pemerintah Daerah Dengan Tingkat Desentralisasi Sebagai Pemoderasi. *Jurnal Tata Kelola & Akuntabilitas Keuangan Negara*, 3(1), 33–48. <https://doi.org/https://doi.org/10.28986/jtaken.v3i1.69>
- Penilaian, S., Pada, P., Belajar, H., & Salatiga, N. (2013). *Economic Education Analysis Journal*. 2(1), 18–23. <https://doi.org/10.15294/eeaj.v10i2.46629>
- Pfeffer, Soetjipto, B. W., & Handoko, T. H. (2003). *Paradigma Baru Manajemen Sumber Daya Manusia* (A. Usmara (ed.); Keempat). Amara Books.
- Prayoga, V. A., Rofingatun, S., & Daat, S. C. (2021). Analisis Implementasi Anggaran Berbasis Kinerja Terhadap Akuntabilitas Kinerja Pemerintah Kabupaten Pegunungan Bintang. *Jurnal Akuntansi, Audit, dan Aset*, 3(2), 67–74. https://doi.org/10.52062/jurnal_aaa.v3i2.52
- Presiden Republik Indonesia. (2008). *PERATURAN PEMERINTAH REPUBLIK INDONESIA NOMOR 60 TAHUN 2008 TENTANG SISTEM PENGENDALIAN INTERN PEMERINTAH*.
- Puspa, D. F., & Prasetyo, R. A. (2020). Pengaruh Kompetensi Pemerintah Desa, Sistem Pengendalian Internal, Dan Aksesibilitas Laporan Keuangan Terhadap Akuntabilitas Pengelolaan Dana Desa. *Media Riset Akuntansi, Auditing & Informasi*, 20(2), 281. <https://doi.org/10.25105/mraai.v20i2.7894>
- Radjab, E., & Jam'an, A. (2017). *Modul Praktikum Penganggaran Perusahaan & Pemerintah*. 81.
- Raharjo, E. (2007). Teori Agensi dan Teori Stewrship dalam Perspektif Akuntansi. *Fokus Ekonomi*, 2(1), 37–46.

- Rahayu, R. P. (2016). Analisis Atas Laporan Realisasi Anggaran Untuk Mengukur Kinerja Keuangan Pemerintah Kabupaten Pamekasan. *Makro: Jurnal Manajemen Dan Kewirausahaan*, 1(01). <https://doi.org/10.36467/makro.2016.01.01.05>
- Ramandei, P., Rohman, A., Ratmono, D., & Ghozali, I. (2020). Interactions of financial assistance and financial reporting competency: Evidence from local government in Papua and West Papua Indonesia. *International Journal of Financial Research*, 11(1), 1–12. <https://doi.org/10.5430/ijfr.v11n1p1>
- Ramon, D. (2014). Pengaruh Sistem Pengendalian Intern terhadap Akuntabilitas Keuangan (Studi Empiris pada Inspektorat Kota Se Provinsi Sumatera Barat. In *Jurnal Akuntansi* (Vol. 2, Nomor 2, hal. 1–19).
- Rasheli, G. A. (2016). Article information :International Journal of Public Sector Management. *Procurement contract management in the local government authorities (LGAs) in Tanzania*, 29(6 pp.), 545–564.
- Rasman. (2018). Kompetensi aparatur desa di wilayah kecamatan budong-budong kabupaten mamuju tengah. *Jurnal Ilmu Administrasi Negara*, 1–14.
- Ridzal, N. A. (2020). Pengaruh Kualitas Laporan Keuangan Terhadap Akuntabilitas Kinerja Pada Badan Pengelolaan Keuangan Dan Aset Daerah (Bpkad) Kabupaten Buton. *Financial: Jurnal Akuntansi*, 6(1), 87–97. <https://doi.org/10.37403/financial.v6i1.135>
- Robbins, S. P. (2007). *Psikologi Organisasi* (Delapan). Prenhallindo.
- Saad, M. H., Arifuddin, & Damayanti, R. A. (2020). *The Effects of Competence and Internal Control Systems on The Accountability of Village Financial Management with Organizing Commitmen as Moderation Variables*. 8(1), 332–338.
- Sapartiningsih, D., Suharno, & Kristianto, D. (2018). Analisis Pengaruh Kompetensi Sumber Daya Manusia, Pemanfaatan Teknologi Informasi, Partisipasi Penganggaran dan Pengawasan Terhadap Akuntabilitas Pengelolaan Dana Desa. *Jurnal Akuntansi dan Sistem Teknologi Informasi*, 14(1 Maret), 100–114.
- Sardjito dan Osmad. 2007 “Pengaruh Partisipasi Penyusunan Anggaran Terhadap Kinerja Aparat Pemerintah Daerah : Budaya Organisasi Dan Komitmen Organisasi Sebagai Variabel Moderating”. SNA X. Juli Agustus. pp 1-24.
- Sarah, S., Taufik, T., & Safitri, D. (2020). Pengaruh kompetensi aparatur, komitmen organisasi, pemanfaatan teknologi informasi, partisipasi masyarakat, dan SPI terhadap akuntabilitas pengelolaan dana desa di kabupaten indragiri hulu. *Bilancia: Jurnal Ilmiah Akuntansi*, 4(4), 330–342.

- Savitri, D. A. M., & Kurniasari, D. (2019). Peran Laporan Keuangan Dan Sistem Pengendalian Internal Terhadap Optimalisasi Penyusunan Anggaran Dana Desa Di Kabupaten Boyolali. *Balance Vocation Accounting Journal*, 3(2), 35. <https://doi.org/10.31000/bvaj.v3i2.2238>
- Sawitri, P. I., & Gayatri, G. (2021). Kejelasan Sasaran Anggaran, Sistem Pelaporan dan Kompetensi Perangkat Desa pada Akuntabilitas Pengelolaan Dana Desa. *E-Jurnal Akuntansi*, 31(2), 476. <https://doi.org/10.24843/eja.2021.v31.i02.p17>
- Simon, Y., Mas'ud, M., & Su'un, M. (2016). The role of apparatus competence, internal control system on good governance and the quality of financial statement information. *Researches World*, 7(4), 123–132. <https://doi.org/10.18843/rwjasc/v7i4/14>
- Sitorus, E. T., Setiyawati, H., & Mappanyuki, R. (2019). The Effectiveness of The Internal Control System On The Quality of Financial Statements With The Implementation of Internal Audits As A Moderation Variable. *International Conference on Rural Development and Entrepreneurship*, 5(1), 1386–1400.
- Standar Akuntansi Pemerintahan, P. N. 2. (2010). *Lampiran II.03 Peraturan Pemerintah No. 71 Tahun 2010*.
- Stevens, J, Applied multivariate Statistics for the social sciences, 4th ed.Hillsdale, NJ;Lawrence Erlbau Publishing. 2001
- Sujarweni, V. W. (2015). *Akuntansi Desa : Panduan Tata Kelola Keuangan Desa*. Yogyakarta: Pustaka Baru Press
- Sululing, S. (2017). Pelaporan keuangan alokasi dana desa sebagai salah satu akuntabilitas keuangan desa. *Jurnal Ekonomi*, 22(2). <https://doi.org/10.24912/je.v22i2.228>
- Supriyono. (2002). *Akuntansi Manajemen, Proses Pengendalian Manajemen*. STIE YKPN.
- Suryanto, D., Subroto, B., & Andayani, W. (2017). *Jurnal Ilmiah Administrasi Publik (JIAP)*. 3(2), 109–121.
- Susanti, E., & Azwar, K. (2021). *Analisis Faktor-Faktor Yang Mempengaruhi Kualitas*. 7, 97–104.
- SUWANDA, D., & SURYANA, D. (2021). Human Resource Development in Local Governments: Increased Transparency and Public Accountability*. *Journal of Asian Finance, Economics and Business*, 8(1), 1063–1069. <https://doi.org/10.13106/jafeb.2021.vol8.no1.1063>
- Syamsi, S. (2014). Partisipasi Masyarakat Dalam Mengontrol Penggunaan Anggaran Dana Desa. *Jurnal Ilmu Sosial dan Ilmu Politik Universitas Tribhuwana Tungadewi*, 3(1), 42389.

- Taufik, T. (2009). PENGELOLAAN KEUANGAN DESA DALAM SISTEM KEUANGAN NEGARA REPUBLIK INDONESIA. *Jurnal Ekonomi*, 17(1), 1–61. <https://je.ejournal.unri.ac.id/index.php/JE/article/view/716/709>
- Thoyibatun, S. (2012). Faktor-faktor yang berpengaruh terhadap perilaku tidak etis dan kecenderungan kecurangan akuntansi serta akibatnya terhadap kinerja organisasi. *Ekuitas: Jurnal Ekonomi dan Keuangan*, 16(2), 245–260.
- Triani, N. N. A., & Handayani, S. (2018). Praktik Pengelolaan Keuangan Dana Desa. *Jurnal Akuntansi Multiparadigma*, 9(1), 136–155. <https://doi.org/10.18202/jamal.2018.04.9009>
- Umaira, S., & Adnan, A. (2019). Pengaruh Partisipasi Masyarakat, Kompetensi Sumber Daya Manusia, Dan Pengawasan Terhadap Akuntabilitas Pengelolaan Dana Desa (Studi Kasus Pada Kabupaten Aceh Barat Daya). *Jurnal Ilmiah Mahasiswa Ekonomi Akuntansi*, 4(3), 471–481.
- Utami, R. (2019). Pengaruh Penyajian Laporan Keuangan, Aksebilitas Laporan Keuangan dan Sistem Akuntansi Keuangan Daerah terhadap Ketepatan Pengelolaan Keuangan Daerah Pada Pemerintah Kota Pontianak. *MAKSI UNTAN*, 4(1).
- Wafirotin, K. Z., & Septiviasuti, U. (2019). the Effect of Transparency, Community Participation, and Accountability on Management of Village Funds in Ponorogo Regency. *Ekuilibrium: Jurnal Ilmiah Bidang Ilmu Ekonomi*, 14(1), 31. <https://doi.org/10.24269/ekuilibrium.v14i1.1527>
- Wahdatul, L., Muda, I., & Erwin, K. (2021). Effect of Performance-Based Budgeting and Financial Reporting Systems on the Performance Accountability of Bekasi Regency Government Agencies. *Budapest International Research ...*, 5477–5485.
- Wahyu, S., Gamayuni, R. R., & Shamsuddeen, M. A. (2019). Analysis The Effect of e-Budgeting and Government Internal Control System on The Quality of Financial Reporting of Local Government in Indonesia in Islamic Perspectives. *Jurnal ekonomi dan bisnis islam ekonomika*, 4(2). <https://doi.org/https://doi.org/10.24042/febi.v4i2.5204>
- Wahyuni, S., Indrawati, N., & Azhar L, A. (2018). Pengaruh Sistem Pengendalian Intern, Sistem Informasi Akuntansi dan Kompetensi Aparat Terhadap Akuntabilitas Penganlolaan Alokasi Dana Desa (Studi Empiris Desa-Desa Di Kabupaten Rokan Hulu). *Jurnal Ekonomi*, 26(3), 98–110.
- Walandouw, S., Tinangon, J., & Dien, A. (2015). Analisis Laporan Realisasi Anggaran Untuk Menilai Kinerja Keuangan Pada Kantor Dinas Pendapatan Daerah Kota Bitung. *Jurnal Riset Ekonomi, Manajemen, Bisnis dan Akuntansi*, 3(1), 534–541.

- Widyatama, A., Novita, L., & Diarespati, D. (2017). Pengaruh Kompetensi Dan Sistem Pengendalian Internal Terhadap Akuntabilitas Pemerintah Desa Dalam Mengelola Alokasi Dana Desa (Add). *Berkala Akuntansi dan Keuangan Indonesia*, 2(2), 1–20. <https://doi.org/10.20473/baki.v2i2.4762>
- Wilopo. (2006). *Analisis Faktor-Faktor Yang Berpengaruh Terhadap Kecenderungan Kecurangan Akuntansi*.
- Yulianto, A. (2020). The Effects of Village Apparatus Competence, Leadership and Accessibility of Village Fund Reports on Accountability of Village Fund Management with Internal Control Systems as Moderating Variables. *Journal of Advanced Research in Dynamical and Control Systems*, 12(3), 713–719. <https://doi.org/10.5373/jardcs/v12i3/20201938>
- Yuniawati, A. S. (2021). the Influence of Village Aparators Competency on the Quality of Village Financial Statements. *International Journal of Economics, Business ...*, 2021(1), 610–622.
- Yusfaningrum, K., & Ghozali, I. (2005). ANALISIS PENGARUH PARTISIPASI ANGGARAN TERHADAP KINERJA MANAJERIAL MELALUI KOMITMEN TUJUAN ANGGARAN DAN JOB RELEVANT INFORMATION (JRI) SEBAGAI VARIABEL INTERVENING (Penelitian Terhadap Perusahaan Manufaktur Di Indonesia). *SNA VIII Solo, September*, 3–6.
- Zainab. (2019). *Pengaruh perencanaan anggaran, laporan realisasi anggaran, evaluasi anggaran dan kompetensi sumber daya manusia terhadap akuntabilitas kinerja perangkat desa*. 241–254.

LAMPIRAN

Lampiran 2 Uji Validitas dan reliabilitas instrumen

Correlations**Correlations**

		Kompetensi
X1.1	Pearson Correlation	,838**
	Sig. (2-tailed)	,000
	N	222
X1.2	Pearson Correlation	,861**
	Sig. (2-tailed)	,000
	N	222
X1.3	Pearson Correlation	,835**
	Sig. (2-tailed)	,000
	N	222

** . Correlation is significant at the 0.01 level (2-tailed).

Reliability

Scale: ALL VARIABLES

Case Processing Summary

		N	%
Cases	Valid	222	100,0
	Excluded ^a	0	,0
	Total	222	100,0

a. Listwise deletion based on all variables in the procedure.

Reliability Statistics

Cronbach's Alpha	N of Items
,977	3

Correlations

Correlations

		Partisipasi Anggaran
X2.1	Pearson Correlation	,949**
	Sig. (2-tailed)	,000
	N	222
X2.2	Pearson Correlation	,975**
	Sig. (2-tailed)	,000
	N	222
X2.3	Pearson Correlation	,970**
	Sig. (2-tailed)	,000
	N	222
X2.4	Pearson Correlation	,969**
	Sig. (2-tailed)	,000
	N	222
X2.5	Pearson Correlation	,964**
	Sig. (2-tailed)	,000
	N	222

** . Correlation is significant at the 0.01 level (2-tailed).

Reliability**Scale: ALL VARIABLES****Case Processing Summary**

		N	%
Cases	Valid	222	100,0
	Excluded ^a	0	,0
	Total	222	100,0

a. Listwise deletion based on all variables in the procedure.

Reliability Statistics

Cronbach's Alpha	N of Items
,987	5

Correlations**Correlations**

		Pengendalian Internal
Y1.1	Pearson Correlation	,925**
	Sig. (2-tailed)	,000
	N	222
Y1.2	Pearson Correlation	,957**
	Sig. (2-tailed)	,000
	N	222

Y1.3	Pearson Correlation	,957**
	Sig. (2-tailed)	,000
	N	222
Y1.4	Pearson Correlation	,842**
	Sig. (2-tailed)	,000
	N	222
Y1.5	Pearson Correlation	,940**
	Sig. (2-tailed)	,000
	N	222

** . Correlation is significant at the 0.01 level (2-tailed).

Reliability

Scale: ALL VARIABLES

Case Processing Summary

		N	%
Cases	Valid	222	100,0
	Excluded ^a	0	,0
	Total	222	100,0

a. Listwise deletion based on all variables in the procedure.

Reliability Statistics

Cronbach's Alpha	N of Items
,963	5

Correlations

Correlations

		Kinerja Laporan Realisasi Anggaran
Y2.1	Pearson Correlation	,947**
	Sig. (2-tailed)	,000
	N	222
Y2.2	Pearson Correlation	,967**
	Sig. (2-tailed)	,000
	N	222
Y2.3	Pearson Correlation	,957**
	Sig. (2-tailed)	,000
	N	222

** . Correlation is significant at the 0.01 level (2-tailed).

Reliability**Scale: ALL VARIABLES****Case Processing Summary**

		N	%
Cases	Valid	222	100,0
	Excluded ^a	0	,0
	Total	222	100,0

a. Listwise deletion based on all variables in the procedure.

Reliability Statistics

Cronbach's Alpha	N of Items
,977	5

Lampiran 3 Distribusi Frekwensi

Frequencies

Statistics

		X1.1.1	X1.1.2	X1.1.3	X1.2.1	X1.2.2
N	Valid	222	222	222	222	222
	Missing	0	0	0	0	0
Mean		4,25	4,36	4,28	4,24	4,31
Median		4,00	5,00	5,00	4,00	5,00

Statistics

		X1.2.3	X1.3.1	X1.3.2	X1.3.3	X1.3.4
N	Valid	222	222	222	222	222
	Missing	0	0	0	0	0
Mean		4,22	4,35	3,73	4,25	4,095
Median		5,00	4,00	4,00	5,00	4,000

Frequency Table

X1.1.1

		Frequency	Percent	Valid Percent	Cumulative Percent
Valid	1	1	,5	,5	,5
	2	1	,5	,5	,9
	3	23	10,4	10,4	11,3
	4	113	50,9	50,9	62,2
	5	84	37,8	37,8	100,0
Total		222	100,0	100,0	

X1.1.2

		Frequency	Percent	Valid Percent	Cumulative Percent
Valid	1	21	9,5	9,5	9,5
	2	4	1,8	1,8	11,3
	3	2	,9	,9	12,2
	4	41	18,5	18,5	30,6
	5	154	69,4	69,4	100,0
	Total	222	100,0	100,0	

X1.1.3

		Frequency	Percent	Valid Percent	Cumulative Percent
Valid	1	21	9,5	9,5	9,5
	2	6	2,7	2,7	12,2
	3	1	,5	,5	12,6
	4	56	25,2	25,2	37,8
	5	138	62,2	62,2	100,0
	Total	222	100,0	100,0	

X1.2.1

		Frequency	Percent	Valid Percent	Cumulative Percent
Valid	1	1	,5	,5	,5
	2	1	,5	,5	,9
	3	12	5,4	5,4	6,3
	4	138	62,2	62,2	68,5
	5	70	31,5	31,5	100,0
	Total	222	100,0	100,0	

X1.2.2

		Frequency	Percent	Valid Percent	Cumulative Percent
Valid	1	22	9,9	9,9	9,9
	2	5	2,3	2,3	12,2
	3	5	2,3	2,3	14,4
	4	40	18,0	18,0	32,4
	5	150	67,6	67,6	100,0
	Total	222	100,0	100,0	

X1.2.3

		Frequency	Percent	Valid Percent	Cumulative Percent
Valid	1	23	10,4	10,4	10,4
	2	4	1,8	1,8	12,2
	3	4	1,8	1,8	14,0
	4	62	27,9	27,9	41,9
	5	129	58,1	58,1	100,0
	Total	222	100,0	100,0	

X1.3.1

		Frequency	Percent	Valid Percent	Cumulative Percent
Valid	1	1	,5	,5	,5
	3	21	9,5	9,5	9,9
	4	99	44,6	44,6	54,5
	5	101	45,5	45,5	100,0
	Total	222	100,0	100,0	

X1.3.2

	Frequency	Percent	Valid Percent	Cumulative Percent
Valid 1	2	,9	,9	,9
2	34	15,3	15,3	16,2
3	29	13,1	13,1	29,3
4	115	51,8	51,8	81,1
5	42	18,9	18,9	100,0
Total	222	100,0	100,0	

X1.3.3

	Frequency	Percent	Valid Percent	Cumulative Percent
Valid 1	22	9,9	9,9	9,9
2	5	2,3	2,3	12,2
3	4	1,8	1,8	14,0
4	55	24,8	24,8	38,7
5	136	61,3	61,3	100,0
Total	222	100,0	100,0	

X1.3.4

	Frequency	Percent	Valid Percent	Cumulative Percent
Valid 1,0	22	9,9	9,9	9,9
2,0	4	1,8	1,8	11,7
3,0	10	4,5	4,5	16,2
4,0	81	36,5	36,5	52,7
5,0	105	47,3	47,3	100,0
Total	222	100,0	100,0	

Frequency Table

X2.1.1

		Frequency	Percent	Valid Percent	Cumulative Percent
Valid	2	2	,9	,9	,9
	3	7	3,2	3,2	4,1
	4	114	51,4	51,4	55,4
	5	99	44,6	44,6	100,0
	Total	222	100,0	100,0	

X2.1.2

		Frequency	Percent	Valid Percent	Cumulative Percent
Valid	1	17	7,7	7,7	7,7
	2	7	3,2	3,2	10,8
	3	17	7,7	7,7	18,5
	4	81	36,5	36,5	55,0
	5	100	45,0	45,0	100,0
	Total	222	100,0	100,0	

X2.1.3

		Frequency	Percent	Valid Percent	Cumulative Percent
Valid	1	9	4,1	4,1	4,1
	2	14	6,3	6,3	10,4
	3	23	10,4	10,4	20,7
	4	92	41,4	41,4	62,2
	5	84	37,8	37,8	100,0
	Total	222	100,0	100,0	

X2.2.1

		Frequency	Percent	Valid Percent	Cumulative Percent
Valid	2	2	,9	,9	,9
	3	6	2,7	2,7	3,6
	4	122	55,0	55,0	58,6
	5	92	41,4	41,4	100,0
	Total	222	100,0	100,0	

X2.2.2

		Frequency	Percent	Valid Percent	Cumulative Percent
Valid	1	13	5,9	5,9	5,9
	2	8	3,6	3,6	9,5
	3	25	11,3	11,3	20,7
	4	96	43,2	43,2	64,0
	5	80	36,0	36,0	100,0
	Total	222	100,0	100,0	

X2.2.3

		Frequency	Percent	Valid Percent	Cumulative Percent
Valid	1	13	5,9	5,9	5,9
	2	10	4,5	4,5	10,4
	3	17	7,7	7,7	18,0
	4	99	44,6	44,6	62,6
	5	83	37,4	37,4	100,0
	Total	222	100,0	100,0	

X2.3.1

		Frequency	Percent	Valid Percent	Cumulative Percent
Valid	2	2	,9	,9	,9
	3	6	2,7	2,7	3,6
	4	196	88,3	88,3	91,9
	5	18	8,1	8,1	100,0
	Total	222	100,0	100,0	

X2.3.2

		Frequency	Percent	Valid Percent	Cumulative Percent
Valid	1	13	5,9	5,9	5,9
	2	13	5,9	5,9	11,7
	3	10	4,5	4,5	16,2
	4	87	39,2	39,2	55,4
	5	99	44,6	44,6	100,0
	Total	222	100,0	100,0	

X2.3.3

		Frequency	Percent	Valid Percent	Cumulative Percent
Valid	1	13	5,9	5,9	5,9
	2	10	4,5	4,5	10,4
	3	12	5,4	5,4	15,8
	4	101	45,5	45,5	61,3
	5	86	38,7	38,7	100,0
	Total	222	100,0	100,0	

X2.4.1

		Frequency	Percent	Valid Percent	Cumulative Percent
Valid	1	1	,5	,5	,5
	3	7	3,2	3,2	3,6
	4	121	54,5	54,5	58,1
	5	93	41,9	41,9	100,0
	Total	222	100,0	100,0	

X2.4.2

		Frequency	Percent	Valid Percent	Cumulative Percent
Valid	1	1	,5	,5	,5
	2	1	,5	,5	,9
	4	173	77,9	77,9	78,8
	5	47	21,2	21,2	100,0
	Total	222	100,0	100,0	

X2.4.3

		Frequency	Percent	Valid Percent	Cumulative Percent
Valid	1	13	5,9	5,9	5,9
	2	10	4,5	4,5	10,4
	3	16	7,2	7,2	17,6
	4	96	43,2	43,2	60,8
	5	87	39,2	39,2	100,0
	Total	222	100,0	100,0	

X2.4.4

	Frequency	Percent	Valid Percent	Cumulative Percent
Valid 1	15	6,8	6,8	6,8
2	9	4,1	4,1	10,8
3	16	7,2	7,2	18,0
4	105	47,3	47,3	65,3
5	77	34,7	34,7	100,0
Total	222	100,0	100,0	

X2.5.1

	Frequency	Percent	Valid Percent	Cumulative Percent
Valid 1	1	,5	,5	,5
2	1	,5	,5	,9
3	7	3,2	3,2	4,1
4	197	88,7	88,7	92,8
5	16	7,2	7,2	100,0
Total	222	100,0	100,0	

X2.5.2

		Frequency	Percent	Valid Percent	Cumulative Percent
Valid	1	2	,9	,9	,9
	2	1	,5	,5	1,4
	4	165	74,3	74,3	75,7
	5	54	24,3	24,3	100,0
	Total	222	100,0	100,0	

X2.5.3

		Frequency	Percent	Valid Percent	Cumulative Percent
Valid	1	1	,5	,5	,5
	2	14	6,3	6,3	6,8
	3	42	18,9	18,9	25,7
	4	148	66,7	66,7	92,3
	5	17	7,7	7,7	100,0
	Total	222	100,0	100,0	

X2.5.4

		Frequency	Percent	Valid Percent	Cumulative Percent
Valid	1	13	5,9	5,9	5,9
	2	10	4,5	4,5	10,4
	3	14	6,3	6,3	16,7
	4	115	51,8	51,8	68,5
	5	70	31,5	31,5	100,0
	Total	222	100,0	100,0	

X2.5.5

		Frequency	Percent	Valid Percent	Cumulative Percent
Valid	1	13	5,9	5,9	5,9
	2	13	5,9	5,9	11,7
	3	11	5,0	5,0	16,7
	4	104	46,8	46,8	63,5
	5	81	36,5	36,5	100,0
	Total	222	100,0	100,0	

Frequencies**Statistics**

		Y1.1.1	Y1.1.2	Y1.1.3	Y1.2.1	Y1.2.2	Y1.2.3
N	Valid	222	222	222	222	222	222
	Missing	0	0	0	0	0	0
Mean		4,23	4,14	4,13	4,29	4,47	4,08
Median		4,00	4,00	4,00	4,00	5,00	4,00

Statistics

		Y1.2.4	Y1.3.1	Y1.3.2	Y1.3.3	Y1.4.1
N	Valid	222	222	222	222	222
	Missing	0	0	0	0	0
Mean		3,98	4,14	4,08	4,06	4,42
Median		4,00	4,00	4,00	4,00	4,00

Statistics

		Y1.4.2	Y1.4.3	Y1.5.1	Y1.5.2	Y1.5.3
N	Valid	222	222	222	222	222
	Missing	0	0	0	0	0
Mean		4,76	4,03	3,82	4,03	4,00
Median		5,00	4,00	4,00	4,00	4,00

Frequency Table

Y1.1.1

		Frequency	Percent	Valid Percent	Cumulative Percent
Valid	3	19	8,6	8,6	8,6
	4	133	59,9	59,9	68,5
	5	70	31,5	31,5	100,0
	Total	222	100,0	100,0	

Y1.1.2

		Frequency	Percent	Valid Percent	Cumulative Percent
Valid	1	17	7,7	7,7	7,7
	2	5	2,3	2,3	9,9
	3	11	5,0	5,0	14,9
	4	87	39,2	39,2	54,1
	5	102	45,9	45,9	100,0
	Total	222	100,0	100,0	

Y1.1.3

		Frequency	Percent	Valid Percent	Cumulative Percent
Valid	1	17	7,7	7,7	7,7
	2	8	3,6	3,6	11,3
	3	9	4,1	4,1	15,3
	4	84	37,8	37,8	53,2
	5	104	46,8	46,8	100,0
	Total	222	100,0	100,0	

Y1.2.1

		Frequency	Percent	Valid Percent	Cumulative Percent
Valid	3	21	9,5	9,5	9,5
	4	115	51,8	51,8	61,3
	5	86	38,7	38,7	100,0
	Total	222	100,0	100,0	

Y1.2.2

		Frequency	Percent	Valid Percent	Cumulative Percent
Valid	3	9	4,1	4,1	4,1
	4	100	45,0	45,0	49,1
	5	113	50,9	50,9	100,0
	Total	222	100,0	100,0	

Y1.2.3

		Frequency	Percent	Valid Percent	Cumulative Percent
Valid	1	19	8,6	8,6	8,6
	2	6	2,7	2,7	11,3
	3	9	4,1	4,1	15,3
	4	92	41,4	41,4	56,8
	5	96	43,2	43,2	100,0
	Total	222	100,0	100,0	

Y1.2.4

		Frequency	Percent	Valid Percent	Cumulative Percent
Valid	1	17	7,7	7,7	7,7
	2	9	4,1	4,1	11,7
	3	19	8,6	8,6	20,3
	4	93	41,9	41,9	62,2
	5	84	37,8	37,8	100,0
	Total	222	100,0	100,0	

Y1.3.1

		Frequency	Percent	Valid Percent	Cumulative Percent
Valid	3	57	25,7	25,7	25,7
	4	78	35,1	35,1	60,8
	5	87	39,2	39,2	100,0
	Total	222	100,0	100,0	

Y1.3.2

		Frequency	Percent	Valid Percent	Cumulative Percent
Valid	1	19	8,6	8,6	8,6
	2	5	2,3	2,3	10,8
	3	12	5,4	5,4	16,2
	4	90	40,5	40,5	56,8
	5	96	43,2	43,2	100,0
	Total	222	100,0	100,0	

Y1.3.3

		Frequency	Percent	Valid Percent	Cumulative Percent
Valid	1	17	7,7	7,7	7,7
	2	10	4,5	4,5	12,2
	3	11	5,0	5,0	17,1
	4	89	40,1	40,1	57,2
	5	95	42,8	42,8	100,0
	Total	222	100,0	100,0	

Y1.4.1

		Frequency	Percent	Valid Percent	Cumulative Percent
Valid	3	7	3,2	3,2	3,2
	4	115	51,8	51,8	55,0
	5	100	45,0	45,0	100,0
	Total	222	100,0	100,0	

Y1.4.2

		Frequency	Percent	Valid Percent	Cumulative Percent
Valid	3	11	5,0	5,0	5,0
	4	32	14,4	14,4	19,4
	5	179	80,6	80,6	100,0
	Total	222	100,0	100,0	

Y1.4.3

		Frequency	Percent	Valid Percent	Cumulative Percent
Valid	1	15	6,8	6,8	6,8
	2	10	4,5	4,5	11,3
	3	13	5,9	5,9	17,1
	4	100	45,0	45,0	62,2
	5	84	37,8	37,8	100,0
	Total	222	100,0	100,0	

Y1.5.1

		Frequency	Percent	Valid Percent	Cumulative Percent
Valid	2	18	8,1	8,1	8,1
	3	32	14,4	14,4	22,5
	4	143	64,4	64,4	86,9
	5	29	13,1	13,1	100,0
	Total	222	100,0	100,0	

Y1.5.2

		Frequency	Percent	Valid Percent	Cumulative Percent
Valid	1	15	6,8	6,8	6,8
	2	8	3,6	3,6	10,4
	3	12	5,4	5,4	15,8
	4	107	48,2	48,2	64,0
	5	80	36,0	36,0	100,0
	Total	222	100,0	100,0	

Y1.5.3

		Frequency	Percent	Valid Percent	Cumulative Percent
Valid	1	15	6,8	6,8	6,8
	2	4	1,8	1,8	8,6
	3	27	12,2	12,2	20,7
	4	97	43,7	43,7	64,4
	5	79	35,6	35,6	100,0
	Total	222	100,0	100,0	

Frequencies

Statistics

		Y2.1.1	Y2.1.2	Y2.1.3	Y2.2.1	Y2.2.2
N	Valid	222	222	222	222	222
	Missing	0	0	0	0	0
Mean		4,38	3,98	3,91	4,18	4,49
Median		4,00	4,00	4,00	4,00	4,00

Statistics

		Y2.2.3	Y2.2.4	Y2.3.1	Y2.3.2	Y2.3.3
N	Valid	222	222	222	222	222
	Missing	0	0	0	0	0
Mean		3,95	3,96	4,22	4,09	3,67
Median		4,00	4,00	4,00	4,00	4,00

Frequency Table

Y2.1.1

		Frequency	Percent	Valid Percent	Cumulative Percent
Valid	2	1	,5	,5	,5
	3	2	,9	,9	1,4
	4	131	59,0	59,0	60,4
	5	88	39,6	39,6	100,0
	Total	222	100,0	100,0	

Y2.1.2

		Frequency	Percent	Valid Percent	Cumulative Percent
Valid	1	15	6,8	6,8	6,8
	2	8	3,6	3,6	10,4
	3	17	7,7	7,7	18,0
	4	108	48,6	48,6	66,7
	5	74	33,3	33,3	100,0
	Total	222	100,0	100,0	

Y2.1.3

		Frequency	Percent	Valid Percent	Cumulative Percent
Valid	1	18	8,1	8,1	8,1
	2	6	2,7	2,7	10,8
	3	23	10,4	10,4	21,2
	4	105	47,3	47,3	68,5
	5	70	31,5	31,5	100,0
	Total	222	100,0	100,0	

Y2.2.1

		Frequency	Percent	Valid Percent	Cumulative Percent
Valid	3	17	7,7	7,7	7,7
	4	149	67,1	67,1	74,8
	5	56	25,2	25,2	100,0
	Total	222	100,0	100,0	

Y2.2.2

		Frequency	Percent	Valid Percent	Cumulative Percent
Valid	4	114	51,4	51,4	51,4
	5	108	48,6	48,6	100,0
	Total	222	100,0	100,0	

Y2.2.3

		Frequency	Percent	Valid Percent	Cumulative Percent
Valid	1	15	6,8	6,8	6,8
	2	11	5,0	5,0	11,7
	3	23	10,4	10,4	22,1
	4	93	41,9	41,9	64,0
	5	80	36,0	36,0	100,0
	Total	222	100,0	100,0	

Y2.2.4

		Frequency	Percent	Valid Percent	Cumulative Percent
Valid	1	17	7,7	7,7	7,7
	2	8	3,6	3,6	11,3
	3	21	9,5	9,5	20,7
	4	97	43,7	43,7	64,4
	5	79	35,6	35,6	100,0
	Total	222	100,0	100,0	

Y2.3.1

		Frequency	Percent	Valid Percent	Cumulative Percent
Valid	3	2	,9	,9	,9
	4	170	76,6	76,6	77,5
	5	50	22,5	22,5	100,0
	Total	222	100,0	100,0	

Y2.3.2

		Frequency	Percent	Valid Percent	Cumulative Percent
Valid	1	17	7,7	7,7	7,7
	2	9	4,1	4,1	11,7
	3	5	2,3	2,3	14,0
	4	96	43,2	43,2	57,2
	5	95	42,8	42,8	100,0
	Total	222	100,0	100,0	

Y2.3.3

		Frequency	Percent	Valid Percent	Cumulative Percent
Valid	1	21	9,5	9,5	9,5
	2	11	5,0	5,0	14,4
	3	52	23,4	23,4	37,8
	4	75	33,8	33,8	71,6
	5	63	28,4	28,4	100,0
	Total	222	100,0	100,0	

Lampiran 4 CFA

Eksogen

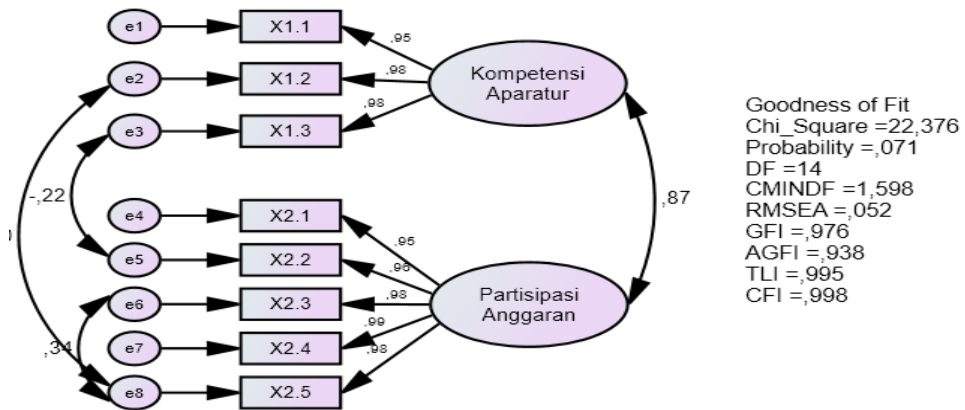

Scalar Estimates (Group number 1 - Default model)

Maximum Likelihood Estimates

Regression Weights: (Group number 1 - Default model)

	Estimate	S.E.	C.R.	P
X1.1 <--- Kompetensi_Aparatur	,932	,025	36,752	***
X1.2 <--- Kompetensi_Aparatur	1,000			
X1.3 <--- Kompetensi_Aparatur	,972	,020	48,427	***
X2.1 <--- Partisipasi_Anggaran	,937	,030	31,413	***
X2.2 <--- Partisipasi_Anggaran	,967	,028	34,626	***
X2.3 <--- Partisipasi_Anggaran	1,000			
X2.4 <--- Partisipasi_Anggaran	,999	,025	40,734	***
X2.5 <--- Partisipasi_Anggaran	,973	,022	43,934	***

Standardized Regression Weights: (Group number 1 - Default model)

	Estimate
X1.1 <--- Kompetensi_Aparatur	,945
X1.2 <--- Kompetensi_Aparatur	,981
X1.3 <--- Kompetensi_Aparatur	,976
X2.1 <--- Partisipasi_Anggaran	,949
X2.2 <--- Partisipasi_Anggaran	,965
X2.3 <--- Partisipasi_Anggaran	,981
X2.4 <--- Partisipasi_Anggaran	,989
X2.5 <--- Partisipasi_Anggaran	,976

Endogen

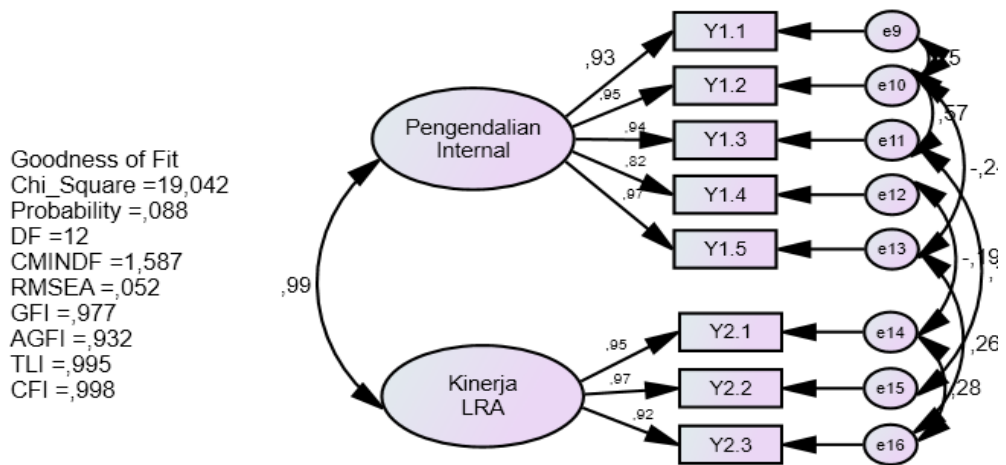

Scalar Estimates (Group number 1 - Default model)

Maximum Likelihood Estimates**Regression Weights: (Group number 1 - Default model)**

	Estimate	S.E.	C.R.	P
Y1.1 <--- Pengendalian_Internal	,971	,035	27,497	***
Y1.2 <--- Pengendalian_Internal	,993	,022	45,021	***
Y1.3 <--- Pengendalian_Internal	1,000			
Y1.4 <--- Pengendalian_Internal	,466	,025	18,626	***
Y1.5 <--- Pengendalian_Internal	,955	,029	33,484	***
Y2.1 <--- Kinerja_LRA	,940	,027	34,950	***
Y2.2 <--- Kinerja_LRA	1,000			
Y2.3 <--- Kinerja_LRA	,913	,031	29,318	***

Standardized Regression Weights: (Group number 1 - Default model)

	Estimate
Y1.1 <--- Pengendalian_Internal	,932
Y1.2 <--- Pengendalian_Internal	,953
Y1.3 <--- Pengendalian_Internal	,939
Y1.4 <--- Pengendalian_Internal	,819
Y1.5 <--- Pengendalian_Internal	,973
Y2.1 <--- Kinerja_LRA	,950
Y2.2 <--- Kinerja_LRA	,969
Y2.3 <--- Kinerja_LRA	,920

Lampiran 5 Uji Univariate Outliers

Descriptives**Descriptive Statistics**

	N	Minimum	Maximum	Mean	Std. Deviation
Zscore(X1.1)	222	-2,76847	,56496	,0000000	1,00000000
Zscore(X1.2)	222	-2,63177	,59392	,0000000	1,00000000
Zscore(X1.3)	222	-3,35771	,82853	,0565708	,67900878
Zscore(X2.1)	222	-3,79762	,97004	,1396334	,71272559
Zscore(X2.2)	222	-3,68565	1,05115	,1265487	,69721844
Zscore(X2.3)	222	-3,64918	1,13117	-,0020087	,65467919
Zscore(X2.4)	222	-3,70042	,97013	,1732930	,68691701
Zscore(X2.5)	222	-3,75080	1,14552	,0829961	,64395795
Zscore(Y1.1)	222	-2,80032	,77764	,0000000	1,00000000
Zscore(Y1.2)	222	-2,70158	,86306	,0000000	1,00000000
Zscore(Y1.3)	222	-2,68490	,81611	,0000000	1,00000000
Zscore(Y1.4)	222	-2,27942	,99586	,0000000	1,00000000
Zscore(Y1.5)	222	-2,85943	,93605	,0000000	1,00000000
Zscore(Y2.1)	222	-2,76281	,98566	,0000000	1,00000000
Zscore(Y2.2)	222	-2,65903	,93765	,0000000	1,00000000
Zscore(Y2.3)	222	-2,68918	1,04498	,0000000	1,00000000
Valid N (listwise)	222				

Lampiran 6 Model Awal

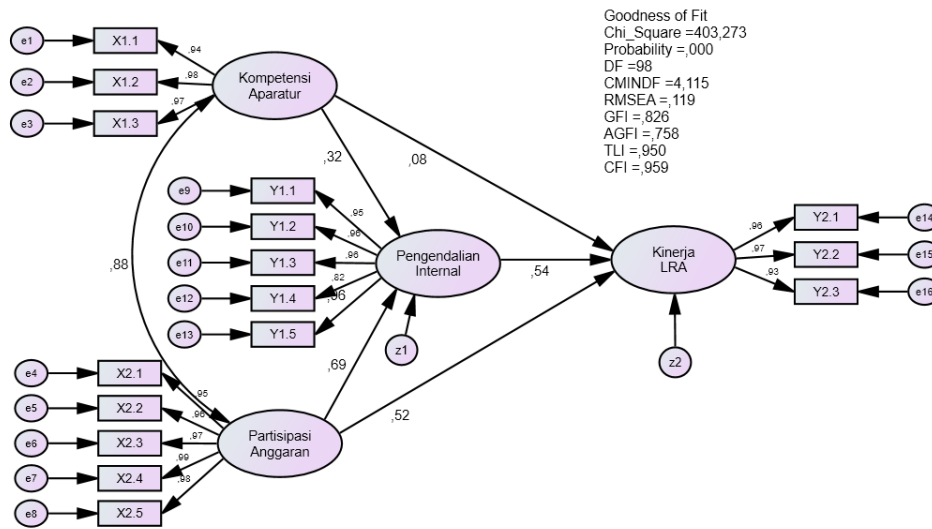

Analysis Summary

Date and Time

Title

Model awal ar: 13 Februari 2023 22.17

Notes for Group (Group number 1)

The model is recursive.

Sample size = 222

Parameter Summary (Group number 1)

	Weights	Covariances	Variances	Means	Intercepts	Total
Fixed	22	0	0	0	0	22
Labeled	0	0	0	0	0	0
Unlabeled	17	1	20	0	0	38
Total	39	1	20	0	0	60

Assessment of normality (Group number 1)

Variable	min	max	skew	c.r.	kurtosis	c.r.
Y1.5	1,000	5,000	-1,561	-9,496	2,161	6,572
X2.5	1,000	5,000	-1,486	-9,040	1,821	5,539
Y2.3	1,000	5,000	-1,279	-7,781	1,352	4,112
Y2.2	1,000	5,000	-1,341	-8,158	1,279	3,891
Y2.1	1,000	5,000	-1,471	-8,950	1,826	5,555
Y1.1	1,000	5,000	-1,700	-10,340	2,236	6,802
Y1.2	1,000	5,000	-1,533	-9,324	1,715	5,216
Y1.3	1,000	5,000	-1,571	-9,559	1,730	5,261
Y1.4	3,000	5,000	-1,046	-6,360	,195	,594
X2.1	1,000	5,000	-1,569	-9,546	1,928	5,865
X2.2	1,000	5,000	-1,446	-8,796	1,757	5,342
X2.3	1,000	5,000	-1,552	-9,443	1,881	5,720
X2.4	1,000	5,000	-1,502	-9,139	1,819	5,533
X1.1	1,000	5,000	-2,006	-12,202	2,735	8,319
X1.2	1,000	5,000	-1,884	-11,459	2,201	6,694
X1.3	1,000	5,000	-1,798	-10,935	2,089	6,354
Multivariate					165,490	51,370

Observations farthest from the centroid (Mahalanobis distance) (Group number 1)

Observation number	Mahalanobis d-squared	p1	p2
120	74,559	,000	,000
101	73,208	,000	,000
82	62,740	,000	,000
135	55,035	,000	,000
102	53,903	,000	,000
143	44,058	,000	,000
5	44,022	,000	,000
217	44,022	,000	,000
44	43,254	,000	,000
178	43,254	,000	,000
88	42,204	,000	,000
128	41,921	,000	,000
144	41,366	,000	,000
147	39,560	,001	,000
49	38,861	,001	,000
183	38,861	,001	,000
95	38,465	,001	,000
119	38,384	,001	,000
137	37,989	,002	,000
64	37,229	,002	,000
198	37,229	,002	,000
113	36,954	,002	,000
28	35,976	,003	,000
162	35,976	,003	,000
132	35,603	,003	,000
15	35,163	,004	,000
149	35,163	,004	,000
52	33,912	,006	,000
186	33,912	,006	,000
32	33,408	,007	,000
166	33,408	,007	,000
72	32,901	,008	,000
206	32,901	,008	,000
34	32,091	,010	,000
168	32,091	,010	,000
56	31,908	,010	,000
190	31,908	,010	,000
24	30,838	,014	,000

Observation number	Mahalanobis d-squared	p1	p2
158	30,838	,014	,000
53	29,604	,020	,000
187	29,604	,020	,000
83	28,350	,029	,000
127	27,910	,032	,000
145	27,593	,035	,000
51	26,076	,053	,000
185	26,076	,053	,000
57	25,803	,057	,000
191	25,803	,057	,000
48	25,188	,067	,000
182	25,188	,067	,000
63	25,093	,068	,000
197	25,093	,068	,000
121	24,665	,076	,000
142	24,202	,085	,000
3	23,148	,110	,000
215	23,148	,110	,000
46	22,974	,114	,000
180	22,974	,114	,000
4	22,094	,140	,000
216	22,094	,140	,000
75	22,040	,142	,000
209	22,040	,142	,000
99	21,673	,154	,000
31	21,648	,155	,000
165	21,648	,155	,000
67	20,592	,195	,000
201	20,592	,195	,000
81	20,264	,209	,000
13	20,109	,215	,001
17	20,051	,218	,000
151	20,051	,218	,000
30	19,883	,226	,000
164	19,883	,226	,000
91	18,626	,289	,082
103	18,433	,299	,119
11	18,321	,305	,131
146	17,963	,326	,276

Observation number	Mahalanobis d-squared	p1	p2
37	17,708	,341	,400
171	17,708	,341	,347
54	16,874	,394	,862
188	16,874	,394	,829
6	16,207	,439	,985
218	16,207	,439	,978
87	15,861	,463	,995
71	15,809	,466	,995
205	15,809	,466	,993
93	15,741	,471	,993
109	15,679	,476	,993
97	14,963	,527	1,000
73	14,676	,548	1,000
207	14,676	,548	1,000
18	14,504	,561	1,000
152	14,504	,561	1,000
38	14,348	,573	1,000
172	14,348	,573	1,000
59	14,038	,596	1,000
193	14,038	,596	1,000
60	13,790	,614	1,000
194	13,790	,614	1,000
131	13,644	,625	1,000

Notes for Model (Default model)

Computation of degrees of freedom (Default model)

Number of distinct sample moments: 136

Number of distinct parameters to be estimated: 38

Degrees of freedom (136 - 38): 98

Result (Default model)

Minimum was achieved

Chi-square = 403,273

Degrees of freedom = 98

Probability level = ,000

Estimates (Group number 1 - Default model)

Scalar Estimates (Group number 1 - Default model)

Maximum Likelihood Estimates

Regression Weights: (Group number 1 - Default model)

		Estimate	S.E.	C.R.	P
Pengendalian_Internal	<--- Kompetensi_Aparatur	,286	,032	8,880	***
Pengendalian_Internal	<--- Partisipasi_Anggaran	,717	,039	18,192	***
Kinerja_LRA	<--- Kompetensi_Aparatur	,073	,055	1,323	,186
Kinerja_LRA	<--- Partisipasi_Anggaran	,533	,115	4,628	***
Kinerja_LRA	<--- Pengendalian_Internal	,535	,149	3,586	***
X1.1	<--- Kompetensi_Aparatur	,927	,025	37,094	***
X1.2	<--- Kompetensi_Aparatur	1,000			
X1.3	<--- Kompetensi_Aparatur	,962	,020	48,385	***
X2.1	<--- Partisipasi_Anggaran	,942	,023	40,315	***
X2.2	<--- Partisipasi_Anggaran	,968	,021	45,070	***
X2.3	<--- Partisipasi_Anggaran	,991	,021	47,663	***
X2.4	<--- Partisipasi_Anggaran	1,000			
X2.5	<--- Partisipasi_Anggaran	,979	,018	54,489	***
Y1.1	<--- Pengendalian_Internal	,976	,029	33,176	***
Y1.2	<--- Pengendalian_Internal	,991	,028	35,626	***
Y1.3	<--- Pengendalian_Internal	1,000			
Y1.4	<--- Pengendalian_Internal	,458	,024	19,275	***
Y1.5	<--- Pengendalian_Internal	,926	,027	34,414	***

		Estimate	S.E.	C.R.	P
Y2.1	<--- Kinerja_LRA	,948	,026	36,264	***
Y2.2	<--- Kinerja_LRA	1,000			
Y2.3	<--- Kinerja_LRA	,925	,030	30,809	***

Standardized Regression Weights: (Group number 1 - Default model)

		Estimate
Pengendalian_Internal	<--- Kompetensi_Aparatur	,320
Pengendalian_Internal	<--- Partisipasi_Anggaran	,693
Kinerja_LRA	<--- Kompetensi_Aparatur	,083
Kinerja_LRA	<--- Partisipasi_Anggaran	,522
Kinerja_LRA	<--- Pengendalian_Internal	,543
X1.1	<--- Kompetensi_Aparatur	,943
X1.2	<--- Kompetensi_Aparatur	,985
X1.3	<--- Kompetensi_Aparatur	,973
X2.1	<--- Partisipasi_Anggaran	,951
X2.2	<--- Partisipasi_Anggaran	,963
X2.3	<--- Partisipasi_Anggaran	,968
X2.4	<--- Partisipasi_Anggaran	,986
X2.5	<--- Partisipasi_Anggaran	,978
Y1.1	<--- Pengendalian_Internal	,953
Y1.2	<--- Pengendalian_Internal	,964
Y1.3	<--- Pengendalian_Internal	,955
Y1.4	<--- Pengendalian_Internal	,819
Y1.5	<--- Pengendalian_Internal	,959

		Estimate
Y2.1	<--- Kinerja_LRA	,956
Y2.2	<--- Kinerja_LRA	,968
Y2.3	<--- Kinerja_LRA	,929

Covariances: (Group number 1 - Default model)

		Estimate	S.E.	C.R.	P
Kompetensi_Aparatur	<--> Partisipasi_Anggaran	1,122	,116	9,650	***

Correlations: (Group number 1 - Default model)

		Estimate
Kompetensi_Aparatur	<--> Partisipasi_Anggaran	,876

Variances: (Group number 1 - Default model)

	Estimate	S.E.	C.R.	P
Kompetensi_Aparatur	1,485	,146	10,182	***
Partisipasi_Anggaran	1,106	,108	10,225	***
z1	,035	,007	5,186	***
z2	,038	,009	4,420	***
e3	,078	,011	6,957	***
e2	,046	,010	4,642	***
e1	,158	,017	9,059	***
e7	,031	,004	7,117	***
e6	,074	,008	9,126	***
e5	,082	,009	9,329	***

	Estimate	S.E.	C.R.	P
e4	,104	,011	9,633	***
e12	,122	,012	10,240	***
e11	,113	,013	9,074	***
e10	,088	,010	8,666	***
e9	,115	,013	9,163	***
e14	,098	,012	8,341	***
e15	,079	,011	7,409	***
e16	,156	,017	9,255	***
e8	,048	,006	8,407	***
e13	,089	,010	8,938	***

Matrices (Group number 1 - Default model)

Total Effects (Group number 1 - Default model)

	Partisipasi Anggaran	Kompetensi	Pengendalian Internal	Kinerja LRA
Pengendalian_Internal	,717	,286	,000	,000
Kinerja_LRA	,917	,226	,535	,000
Y1.5	,664	,265	,926	,000
X2.5	,979	,000	,000	,000
Y2.3	,848	,074	,495	,925
Y2.2	,917	,080	,535	1,000
Y2.1	,869	,076	,507	,948
Y1.1	,700	,279	,976	,000
Y1.2	,711	,283	,991	,000

	Partisipasi Anggaran	Kompetensi	Pengendalian Internal	Kinerja LRA
Y1.3	,717	,286	1,000	,000
Y1.4	,329	,131	,458	,000
X2.1	,942	,000	,000	,000
X2.2	,968	,000	,000	,000
X2.3	,991	,000	,000	,000
X2.4	1,000	,000	,000	,000
X1.1	,000	,927	,000	,000
X1.2	,000	1,000	,000	,000
X1.3	,000	,962	,000	,000

Standardized Total Effects (Group number 1 - Default model)

	Partisipasi Anggaran	Kompetensi	Pengendalian Internal	Kinerja LRA
Pengendalian_Internal	,693	,320	,000	,000
Kinerja_LRA	,898	,257	,543	,000
Y1.5	,664	,307	,959	,000
X2.5	,978	,000	,000	,000
Y2.3	,835	,084	,505	,929
Y2.2	,869	,088	,525	,968
Y2.1	,859	,087	,519	,956
Y1.1	,660	,305	,953	,000
Y1.2	,668	,308	,964	,000
Y1.3	,662	,306	,955	,000
Y1.4	,567	,262	,819	,000

	Partisipasi Anggaran	Kompetensi	Pengendalian Internal	Kinerja LRA
X2.1	,951	,000	,000	,000
X2.2	,963	,000	,000	,000
X2.3	,968	,000	,000	,000
X2.4	,986	,000	,000	,000
X1.1	,000	,943	,000	,000
X1.2	,000	,985	,000	,000
X1.3	,000	,973	,000	,000

Direct Effects (Group number 1 - Default model)

	Partisipasi Anggaran	Kompetensi	Pengendalian Internal	Kinerja LRA
Pengendalian_Internal	,717	,286	,000	,000
Kinerja_LRA	,533	,073	,535	,000
Y1.5	,000	,000	,926	,000
X2.5	,979	,000	,000	,000
Y2.3	,000	,000	,000	,925
Y2.2	,000	,000	,000	1,000
Y2.1	,000	,000	,000	,948
Y1.1	,000	,000	,976	,000
Y1.2	,000	,000	,991	,000
Y1.3	,000	,000	1,000	,000
Y1.4	,000	,000	,458	,000
X2.1	,942	,000	,000	,000
X2.2	,968	,000	,000	,000

	Partisipasi Anggaran	Kompetensi	Pengendalian Internal	Kinerja LRA
X2.3	,991	,000	,000	,000
X2.4	1,000	,000	,000	,000
X1.1	,000	,927	,000	,000
X1.2	,000	1,000	,000	,000
X1.3	,000	,962	,000	,000

Standardized Direct Effects (Group number 1 - Default model)

	Partisipasi Anggaran	Kompetensi	Pengendalian Internal	Kinerja LRA
Pengendalian_Internal	,693	,320	,000	,000
Kinerja_LRA	,522	,083	,543	,000
Y1.5	,000	,000	,959	,000
X2.5	,978	,000	,000	,000
Y2.3	,000	,000	,000	,929
Y2.2	,000	,000	,000	,968
Y2.1	,000	,000	,000	,956
Y1.1	,000	,000	,953	,000
Y1.2	,000	,000	,964	,000
Y1.3	,000	,000	,955	,000
Y1.4	,000	,000	,819	,000
X2.1	,951	,000	,000	,000
X2.2	,963	,000	,000	,000
X2.3	,968	,000	,000	,000
X2.4	,986	,000	,000	,000

	Partisipasi Anggaran	Kompetensi	Pengendalian Internal	Kinerja LRA
X1.1	,000	,943	,000	,000
X1.2	,000	,985	,000	,000
X1.3	,000	,973	,000	,000

Indirect Effects (Group number 1 - Default model)

	Partisipasi Anggaran	Kompetensi	Pengendalian Internal	Kinerja LRA
Pengendalian_Internal	,000	,000	,000	,000
Kinerja_LRA	,384	,153	,000	,000
Y1.5	,664	,265	,000	,000
X2.5	,000	,000	,000	,000
Y2.3	,848	,074	,495	,000
Y2.2	,917	,080	,535	,000
Y2.1	,869	,076	,507	,000
Y1.1	,700	,279	,000	,000
Y1.2	,711	,283	,000	,000
Y1.3	,717	,286	,000	,000
Y1.4	,329	,131	,000	,000
X2.1	,000	,000	,000	,000
X2.2	,000	,000	,000	,000
X2.3	,000	,000	,000	,000
X2.4	,000	,000	,000	,000
X1.1	,000	,000	,000	,000
X1.2	,000	,000	,000	,000

	Partisipasi Anggaran	Kompetensi	Pengendalian Internal	Kinerja LRA
X1.3	,000	,000	,000	,000

Standardized Indirect Effects (Group number 1 - Default model)

	Partisipasi Anggaran	Kompetensi	Pengendalian Internal	Kinerja LRA
Pengendalian_Internal	,000	,000	,000	,000
Kinerja_LRA	,376	,174	,000	,000
Y1.5	,664	,307	,000	,000
X2.5	,000	,000	,000	,000
Y2.3	,835	,084	,505	,000
Y2.2	,869	,088	,525	,000
Y2.1	,859	,087	,519	,000
Y1.1	,660	,305	,000	,000
Y1.2	,668	,308	,000	,000
Y1.3	,662	,306	,000	,000
Y1.4	,567	,262	,000	,000
X2.1	,000	,000	,000	,000
X2.2	,000	,000	,000	,000
X2.3	,000	,000	,000	,000
X2.4	,000	,000	,000	,000
X1.1	,000	,000	,000	,000
X1.2	,000	,000	,000	,000
X1.3	,000	,000	,000	,000

Modification Indices (Group number 1 - Default model)**Covariances: (Group number 1 - Default model)**

	M.I.	Par Change
e13 <--> Partisipasi_Anggaran	12,089	,040
e13 <--> Kompetensi_Aparatur	12,106	-,047
e13 <--> z1	6,727	-,014
e13 <--> z2	31,231	,035
e8 <--> z2	4,434	-,010
e16 <--> z1	4,701	,016
e16 <--> e13	14,763	,035
e15 <--> e16	5,067	-,020
e14 <--> e13	4,388	,016
e14 <--> e16	10,957	,032
e9 <--> z1	17,258	-,025
e9 <--> z2	24,497	-,035
e9 <--> e15	6,463	-,020
e9 <--> e14	7,751	-,024
e10 <--> Partisipasi_Anggaran	4,186	-,024
e10 <--> z1	7,200	,014
e10 <--> e13	19,276	-,030
e10 <--> e8	4,926	-,012
e11 <--> Partisipasi_Anggaran	6,467	-,033
e11 <--> Kompetensi_Aparatur	5,809	,036
e11 <--> z1	14,404	,023

	M.I.	Par Change
e11 <--> e15	5,292	,018
e11 <--> e9	5,810	-,021
e11 <--> e10	60,185	,060
e12 <--> e14	5,473	-,019
e4 <--> Partisipasi_Anggaran	15,398	-,047
e4 <--> Kompetensi_Aparatur	20,255	,063
e4 <--> e14	5,413	,018
e5 <--> e11	7,042	-,020
e6 <--> z1	5,172	,011
e6 <--> e8	12,389	,016
e6 <--> e15	15,100	,025
e6 <--> e14	6,234	-,017
e6 <--> e4	4,008	-,013
e6 <--> e5	8,080	-,017
e7 <--> Partisipasi_Anggaran	7,690	,021
e7 <--> Kompetensi_Aparatur	10,149	-,028
e7 <--> e9	6,376	,013
e7 <--> e6	4,951	-,009
e1 <--> z1	4,561	-,016
e1 <--> e10	7,080	-,025
e1 <--> e11	4,871	-,023
e1 <--> e12	4,827	,022
e2 <--> z1	8,230	,015

	M.I.	Par Change
e2 <--> e8	9,550	-,015
e2 <--> e10	8,225	,019
e2 <--> e5	6,922	,016
e3 <--> e8	7,584	,015
e3 <--> e12	7,716	-,022
e3 <--> e5	4,502	-,014

Variances: (Group number 1 - Default model)

	M.I.	Par Change

Regression Weights: (Group number 1 - Default model)

	M.I.	Par Change
Y1.5 <--- Y2.3	6,103	,050
Y1.2 <--- Y1.3	4,706	,042
X2.1 <--- Kompetensi_Aparatur	4,354	,039
X2.1 <--- X1.1	5,211	,043
X2.1 <--- X1.2	4,140	,037
X2.1 <--- X1.3	5,592	,044

Model Fit Summary

CMIN

Model	NPAR	CMIN	DF	P	CMIN/DF
Default model	38	403,273	98	,000	4,115
Saturated model	136	,000	0		

Model	NPAR	CMIN	DF	P	CMIN/DF
Independence model	16	7538,296	120	,000	62,819

RMR, GFI

Model	RMR	GFI	AGFI	PGFI
Default model	,018	,826	,758	,595
Saturated model	,000	1,000		
Independence model	,966	,081	-,042	,071

Baseline Comparisons

Model	NFI Delta1	RFI rho1	IFI Delta2	TLI rho2	CFI
Default model	,947	,934	,959	,950	,959
Saturated model	1,000		1,000		1,000
Independence model	,000	,000	,000	,000	,000

Parsimony-Adjusted Measures

Model	PRATIO	PNFI	PCFI
Default model	,817	,773	,783
Saturated model	,000	,000	,000
Independence model	1,000	,000	,000

NCP

Model	NCP	LO 90	HI 90
Default model	305,273	247,089	371,015
Saturated model	,000	,000	,000

Model	NCP	LO 90	HI 90
Independence model	7418,296	7136,977	7705,926

FMIN

Model	FMIN	F0	LO 90	HI 90
Default model	1,825	1,381	1,118	1,679
Saturated model	,000	,000	,000	,000
Independence model	34,110	33,567	32,294	34,868

RMSEA

Model	RMSEA	LO 90	HI 90	PCLOSE
Default model	,119	,107	,131	,000
Independence model	,529	,519	,539	,000

AIC

Model	AIC	BCC	BIC	CAIC
Default model	479,273	485,606	608,575	646,575
Saturated model	272,000	294,667	734,764	870,764
Independence model	7570,296	7572,963	7624,739	7640,739

ECVI

Model	ECVI	LO 90	HI 90	MECVI
Default model	2,169	1,905	2,466	2,197
Saturated model	1,231	1,231	1,231	1,333
Independence model	34,255	32,982	35,556	34,267

HOELTER

Model	HOELTER .05	HOELTER .01
Default model	67	74
Independence model	5	5

Execution time summary

Minimization: ,063

Miscellaneous: 1,016

Bootstrap: ,000

Total: 1,079

Lampiran 7 Model Akhir

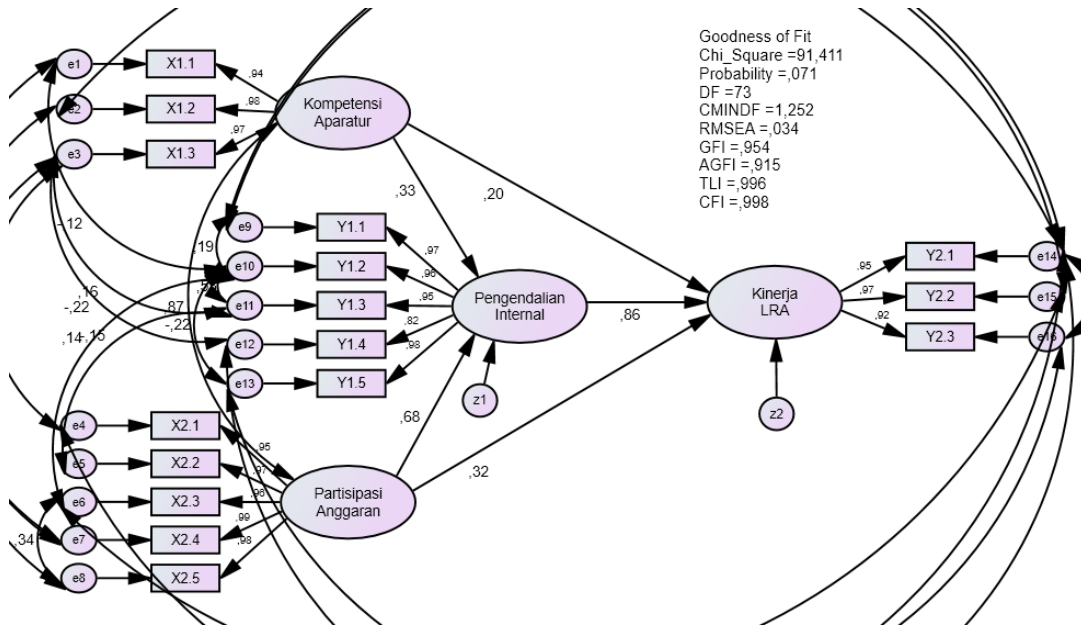

Analysis Summary

Notes for Group (Group number 1)

The model is recursive.

Sample size = 222

Parameter Summary (Group number 1)

	Weights	Covariances	Variances	Means	Intercepts	Total
Fixed	22	0	0	0	0	22
Labeled	0	0	0	0	0	0
Unlabeled	17	26	20	0	0	63
Total	39	26	20	0	0	85

Assessment of normality (Group number 1)

Variable	min	max	skew	c.r.	kurtosis	c.r.
Y1.5	1,000	5,000	-1,561	-9,496	2,161	6,572
X2.5	1,000	5,000	-1,486	-9,040	1,821	5,539
Y2.3	1,000	5,000	-1,279	-7,781	1,352	4,112
Y2.2	1,000	5,000	-1,341	-8,158	1,279	3,891
Y2.1	1,000	5,000	-1,471	-8,950	1,826	5,555
Y1.1	1,000	5,000	-1,700	-10,340	2,236	6,802
Y1.2	1,000	5,000	-1,533	-9,324	1,715	5,216
Y1.3	1,000	5,000	-1,571	-9,559	1,730	5,261
Y1.4	3,000	5,000	-1,046	-6,360	,195	,594
X2.1	1,000	5,000	-1,569	-9,546	1,928	5,865
X2.2	1,000	5,000	-1,446	-8,796	1,757	5,342
X2.3	1,000	5,000	-1,552	-9,443	1,881	5,720
X2.4	1,000	5,000	-1,502	-9,139	1,819	5,533
X1.1	1,000	5,000	-2,006	-12,202	2,735	8,319
X1.2	1,000	5,000	-1,884	-11,459	2,201	6,694
X1.3	1,000	5,000	-1,798	-10,935	2,089	6,354
Multivariate					165,490	51,370

Assessment of normality (Group number 1)

Variable	min	max	skew	c.r.	kurtosis	c.r.
Y1.5	1,000	5,000	-1,561	-9,496	2,161	6,572
X2.5	1,000	5,000	-1,486	-9,040	1,821	5,539
Y2.3	1,000	5,000	-1,279	-7,781	1,352	4,112
Y2.2	1,000	5,000	-1,341	-8,158	1,279	3,891
Y2.1	1,000	5,000	-1,471	-8,950	1,826	5,555
Y1.1	1,000	5,000	-1,700	-10,340	2,236	6,802
Y1.2	1,000	5,000	-1,533	-9,324	1,715	5,216
Y1.3	1,000	5,000	-1,571	-9,559	1,730	5,261
Y1.4	3,000	5,000	-1,046	-6,360	,195	,594
X2.1	1,000	5,000	-1,569	-9,546	1,928	5,865
X2.2	1,000	5,000	-1,446	-8,796	1,757	5,342
X2.3	1,000	5,000	-1,552	-9,443	1,881	5,720
X2.4	1,000	5,000	-1,502	-9,139	1,819	5,533
X1.1	1,000	5,000	-2,006	-12,202	2,735	8,319
X1.2	1,000	5,000	-1,884	-11,459	2,201	6,694
X1.3	1,000	5,000	-1,798	-10,935	2,089	6,354
Multivariate					165,490	51,370

Notes for Model (Default model)**Computation of degrees of freedom (Default model)**

Number of distinct sample moments: 136

Number of distinct parameters to be estimated: 63

Degrees of freedom (136 - 63): 73

Result (Default model)

Minimum was achieved

Chi-square = 91,411

Degrees of freedom = 73

Probability level = ,071

Estimates (Group number 1 - Default model)**Scalar Estimates (Group number 1 - Default model)****Maximum Likelihood Estimates****Regression Weights: (Group number 1 - Default model)**

			Estimate	S.E.	C.R.	P
Pengendalian_Internal	<---	Kompetensi_Aparatur	,296	,032	9,173	***
Pengendalian_Internal	<---	Partisipasi_Anggaran	,693	,039	17,637	***
Kinerja_LRA	<---	Kompetensi_Aparatur	,176	,094	1,782	,069
Kinerja_LRA	<---	Partisipasi_Anggaran	,330	,137	2,407	,016
Kinerja_LRA	<---	Pengendalian_Internal	,854	,186	4,579	***
X1.1	<---	Kompetensi_Aparatur	,930	,025	37,563	***
X1.2	<---	Kompetensi_Aparatur	1,000			
X1.3	<---	Kompetensi_Aparatur	,967	,020	48,325	***
X2.1	<---	Partisipasi_Anggaran	,940	,023	40,846	***
X2.2	<---	Partisipasi_Anggaran	,968	,020	47,737	***
X2.3	<---	Partisipasi_Anggaran	,979	,022	43,532	***
X2.4	<---	Partisipasi_Anggaran	1,000			
X2.5	<---	Partisipasi_Anggaran	,974	,018	54,359	***
Y1.1	<---	Pengendalian_Internal	,998	,033	30,064	***

		Estimate	S.E.	C.R.	P
Y1.2	<--- Pengendalian_Internal	,991	,021	46,372	***
Y1.3	<--- Pengendalian_Internal	1,000			
Y1.4	<--- Pengendalian_Internal	,463	,024	18,971	***
Y1.5	<--- Pengendalian_Internal	,952	,029	33,391	***
Y2.1	<--- Kinerja_LRA	,946	,027	35,540	***
Y2.2	<--- Kinerja_LRA	1,000			
Y2.3	<--- Kinerja_LRA	,914	,031	29,202	***

Standardized Regression Weights: (Group number 1 - Default model)

		Estimate
Pengendalian_Internal	<--- Kompetensi_Aparatur	,334
Pengendalian_Internal	<--- Partisipasi_Anggaran	,679
Kinerja_LRA	<--- Kompetensi_Aparatur	,199
Kinerja_LRA	<--- Partisipasi_Anggaran	,324
Kinerja_LRA	<--- Pengendalian_Internal	,856
X1.1	<--- Kompetensi_Aparatur	,945
X1.2	<--- Kompetensi_Aparatur	,985
X1.3	<--- Kompetensi_Aparatur	,972
X2.1	<--- Partisipasi_Anggaran	,951
X2.2	<--- Partisipasi_Anggaran	,966
X2.3	<--- Partisipasi_Anggaran	,957
X2.4	<--- Partisipasi_Anggaran	,988
X2.5	<--- Partisipasi_Anggaran	,976
Y1.1	<--- Pengendalian_Internal	,966

		Estimate
Y1.2	<--- Pengendalian_Internal	,957
Y1.3	<--- Pengendalian_Internal	,945
Y1.4	<--- Pengendalian_Internal	,820
Y1.5	<--- Pengendalian_Internal	,976
Y2.1	<--- Kinerja_LRA	,952
Y2.2	<--- Kinerja_LRA	,968
Y2.3	<--- Kinerja_LRA	,918

Covariances: (Group number 1 - Default model)

		Estimate	S.E.	C.R.	P
Kompetensi_Aparatur	<--> Partisipasi_Anggaran	1,118	,115	9,713	***
e16	<--> e13	,034	,009	3,829	***
e6	<--> e15	,027	,007	4,114	***
e10	<--> e13	-,020	,006	-3,319	***
e6	<--> e8	,024	,006	4,314	***
e9	<--> z1	-,027	,010	-2,807	,005
e9	<--> e14	-,030	,008	-3,624	***
e3	<--> e8	,021	,005	4,038	***
e9	<--> e15	-,016	,008	-2,079	,038
e3	<--> e4	,020	,007	2,779	,005
e1	<--> e10	-,016	,008	-2,031	,042
e14	<--> e16	,036	,011	3,376	***
e6	<--> e10	,015	,005	2,853	,004
e2	<--> e7	-,019	,005	-3,785	***

		Estimate	S.E.	C.R.	P
e12	<--> e14	-,027	,008	-3,422	***
e1	<--> e7	-,016	,006	-2,437	,015
e2	<--> e14	-,019	,007	-2,788	,005
e4	<--> e14	,017	,007	2,419	,016
e11	<--> e10	,064	,012	5,442	***
e3	<--> e12	-,022	,008	-2,865	,004
e3	<--> e11	,017	,007	2,522	,012
e5	<--> e11	-,015	,006	-2,527	,011
e10	<--> e9	,023	,007	3,086	,002
e6	<--> z1	,012	,005	2,548	,011
e13	<--> Kompetensi_Aparatur	-,039	,014	-2,766	,006
e4	<--> Kompetensi_Aparatur	,053	,015	3,462	***

Correlations: (Group number 1 - Default model)

		Estimate
Kompetensi_Aparatur	<--> Partisipasi_Anggaran	,874
e16	<--> e13	,292
e6	<--> e15	,315
e10	<--> e13	-,221
e6	<--> e8	,341
e9	<--> z1	-,381
e9	<--> e14	-,245
e3	<--> e8	,326
e9	<--> e15	-,157

			Estimate
e3	<-->	e4	,216
e1	<-->	e10	-,121
e14	<-->	e16	,261
e6	<-->	e10	,143
e2	<-->	e7	-,533
e12	<-->	e14	-,234
e1	<-->	e7	-,249
e2	<-->	e14	-,265
e4	<-->	e14	,161
e11	<-->	e10	,528
e3	<-->	e12	-,218
e3	<-->	e11	,160
e5	<-->	e11	-,151
e10	<-->	e9	,189
e6	<-->	z1	,200
e13	<-->	Kompetensi_Aparatur	-,118
e4	<-->	Kompetensi_Aparatur	,134

Variances: (Group number 1 - Default model)

	Estimate	S.E.	C.R.	P
Kompetensi_Aparatur	1,474	,145	10,193	***
Partisipasi_Anggaran	1,111	,108	10,273	***
z1	,037	,009	4,274	***
z2	,111	,034	3,264	***

	Estimate	S.E.	C.R.	P
e3	,081	,011	7,292	***
e2	,046	,009	4,901	***
e1	,154	,017	9,183	***
e7	,026	,004	6,190	***
e6	,098	,010	9,674	***
e5	,075	,008	9,242	***
e4	,105	,011	9,516	***
e12	,122	,012	10,221	***
e11	,139	,015	9,274	***
e10	,106	,013	8,009	***
e9	,137	,017	8,024	***
e14	,107	,012	8,703	***
e15	,077	,010	7,365	***
e16	,179	,019	9,473	***
e8	,052	,006	8,394	***
e13	,076	,010	7,668	***

Matrices (Group number 1 - Default model)

Total Effects (Group number 1 - Default model)

	Partisipasi Anggaran	Kompetensi	Pengendalian Internal	Kinerja LRA
Pengendalian_Internal	,693	,296	,000	,000
Kinerja_LRA	,922	,429	,854	,000
Y1.5	,660	,282	,952	,000

	Partisipasi Anggaran	Kompetensi	Pengendalian Internal	Kinerja LRA
X2.5	,974	,000	,000	,000
Y2.3	,842	,070	,780	,914
Y2.2	,922	,077	,854	1,000
Y2.1	,871	,072	,807	,946
Y1.1	,692	,296	,998	,000
Y1.2	,687	,294	,991	,000
Y1.3	,693	,296	1,000	,000
Y1.4	,321	,137	,463	,000
X2.1	,940	,000	,000	,000
X2.2	,968	,000	,000	,000
X2.3	,979	,000	,000	,000
X2.4	1,000	,000	,000	,000
X1.1	,000	,930	,000	,000
X1.2	,000	1,000	,000	,000
X1.3	,000	,967	,000	,000

Standardized Total Effects (Group number 1 - Default model)

	Partisipasi Anggaran	Kompetensi	Pengendalian Internal	Kinerja LRA
Pengendalian_Internal	,679	,334	,000	,000
Kinerja_LRA	,905	,485	,856	,000
Y1.5	,662	,326	,976	,000
X2.5	,976	,000	,000	,000
Y2.3	,831	,080	,786	,918

	Partisipasi Anggaran	Kompetensi	Pengendalian Internal	Kinerja LRA
Y2.2	,876	,084	,829	,968
Y2.1	,861	,082	,815	,952
Y1.1	,655	,323	,966	,000
Y1.2	,649	,320	,957	,000
Y1.3	,641	,316	,945	,000
Y1.4	,556	,274	,820	,000
X2.1	,951	,000	,000	,000
X2.2	,966	,000	,000	,000
X2.3	,957	,000	,000	,000
X2.4	,988	,000	,000	,000
X1.1	,000	,945	,000	,000
X1.2	,000	,985	,000	,000
X1.3	,000	,972	,000	,000

Direct Effects (Group number 1 - Default model)

	Partisipasi Anggaran	Kompetensi	Pengendalian Internal	Kinerja LRA
Pengendalian_Internal	,693	,296	,000	,000
Kinerja_LRA	,330	,176	,854	,000
Y1.5	,000	,000	,952	,000
X2.5	,974	,000	,000	,000
Y2.3	,000	,000	,000	,914
Y2.2	,000	,000	,000	1,000
Y2.1	,000	,000	,000	,946

	Partisipasi Anggaran	Kompetensi	Pengendalian Internal	Kinerja LRA
Y1.1	,000	,000	,998	,000
Y1.2	,000	,000	,991	,000
Y1.3	,000	,000	1,000	,000
Y1.4	,000	,000	,463	,000
X2.1	,940	,000	,000	,000
X2.2	,968	,000	,000	,000
X2.3	,979	,000	,000	,000
X2.4	1,000	,000	,000	,000
X1.1	,000	,930	,000	,000
X1.2	,000	1,000	,000	,000
X1.3	,000	,967	,000	,000

Standardized Direct Effects (Group number 1 - Default model)

	Partisipasi Anggaran	Kompetensi	Pengendalian Internal	Kinerja LRA
Pengendalian_Internal	,679	,334	,000	,000
Kinerja_LRA	,324	,199	,856	,000
Y1.5	,000	,000	,976	,000
X2.5	,976	,000	,000	,000
Y2.3	,000	,000	,000	,918
Y2.2	,000	,000	,000	,968
Y2.1	,000	,000	,000	,952
Y1.1	,000	,000	,966	,000
Y1.2	,000	,000	,957	,000

	Partisipasi Anggaran	Kompetensi	Pengendalian Internal	Kinerja LRA
Y1.3	,000	,000	,945	,000
Y1.4	,000	,000	,820	,000
X2.1	,951	,000	,000	,000
X2.2	,966	,000	,000	,000
X2.3	,957	,000	,000	,000
X2.4	,988	,000	,000	,000
X1.1	,000	,945	,000	,000
X1.2	,000	,985	,000	,000
X1.3	,000	,972	,000	,000

Indirect Effects (Group number 1 - Default model)

	Partisipasi Anggaran	Kompetensi	Pengendalian Internal	Kinerja LRA
Pengendalian_Internal	,000	,000	,000	,000
Kinerja_LRA	,592	,253	,000	,000
Y1.5	,660	,282	,000	,000
X2.5	,000	,000	,000	,000
Y2.3	,842	,070	,780	,000
Y2.2	,922	,077	,854	,000
Y2.1	,871	,072	,807	,000
Y1.1	,692	,296	,000	,000
Y1.2	,687	,294	,000	,000
Y1.3	,693	,296	,000	,000
Y1.4	,321	,137	,000	,000

	Partisipasi Anggaran	Kompetensi	Pengendalian Internal	Kinerja LRA
X2.1	,000	,000	,000	,000
X2.2	,000	,000	,000	,000
X2.3	,000	,000	,000	,000
X2.4	,000	,000	,000	,000
X1.1	,000	,000	,000	,000
X1.2	,000	,000	,000	,000
X1.3	,000	,000	,000	,000

Standardized Indirect Effects (Group number 1 - Default model)

	Partisipasi Anggaran	Kompetensi	Pengendalian Internal	Kinerja LRA
Pengendalian_Internal	,000	,000	,000	,000
Kinerja_LRA	,581	,286	,000	,000
Y1.5	,662	,326	,000	,000
X2.5	,000	,000	,000	,000
Y2.3	,831	,080	,786	,000
Y2.2	,876	,084	,829	,000
Y2.1	,861	,082	,815	,000
Y1.1	,655	,323	,000	,000
Y1.2	,649	,320	,000	,000
Y1.3	,641	,316	,000	,000
Y1.4	,556	,274	,000	,000
X2.1	,000	,000	,000	,000
X2.2	,000	,000	,000	,000

	Partisipasi Anggaran	Kompetensi	Pengendalian Internal	Kinerja LRA
X2.3	,000	,000	,000	,000
X2.4	,000	,000	,000	,000
X1.1	,000	,000	,000	,000
X1.2	,000	,000	,000	,000
X1.3	,000	,000	,000	,000

Modification Indices (Group number 1 - Default model)

Covariances: (Group number 1 - Default model)

	M.I.	Par Change
e10 <--> e15	4,152	-,011
e11 <--> e15	4,905	,013
e4 <--> e10	4,089	-,011
e6 <--> Kompetensi_Aparatur	4,436	,021
e7 <--> e10	5,330	,008

Variances: (Group number 1 - Default model)

	M.I.	Par Change

Regression Weights: (Group number 1 - Default model)

	M.I.	Par Change

Model Fit Summary

CMIN

Model	NPAR	CMIN	DF	P	CMIN/DF

Model	NPAR	CMIN	DF	P	CMIN/DF
Default model	63	91,411	73	,071	1,252
Saturated model	136	,000	0		
Independence model	16	7538,296	120	,000	62,819

RMR, GFI

Model	RMR	GFI	AGFI	PGFI
Default model	,010	,954	,915	,512
Saturated model	,000	1,000		
Independence model	,966	,081	-,042	,071

Baseline Comparisons

Model	NFI Delta1	RFI rho1	IFI Delta2	TLI rho2	CFI
Default model	,988	,980	,998	,996	,998
Saturated model	1,000		1,000		1,000
Independence model	,000	,000	,000	,000	,000

Parsimony-Adjusted Measures

Model	PRATIO	PNFI	PCFI
Default model	,608	,601	,607
Saturated model	,000	,000	,000
Independence model	1,000	,000	,000

NCP

Model	NCP	LO 90	HI 90

Model	NCP	LO 90	HI 90
Default model	18,411	,000	46,933
Saturated model	,000	,000	,000
Independence model	7418,296	7136,977	7705,926

FMIN

Model	FMIN	F0	LO 90	HI 90
Default model	,414	,083	,000	,212
Saturated model	,000	,000	,000	,000
Independence model	34,110	33,567	32,294	34,868

RMSEA

Model	RMSEA	LO 90	HI 90	PCLOSE
Default model	,034	,000	,054	,901
Independence model	,529	,519	,539	,000

AIC

Model	AIC	BCC	BIC	CAIC
Default model	217,411	227,911	431,779	494,779
Saturated model	272,000	294,667	734,764	870,764
Independence model	7570,296	7572,963	7624,739	7640,739

ECVI

Model	ECVI	LO 90	HI 90	MECVI
Default model	,984	,900	1,113	1,031
Saturated model	1,231	1,231	1,231	1,333

Model	ECVI	LO 90	HI 90	MECVI
Independence model	34,255	32,982	35,556	34,267

HOELTER

Model	HOELTER .05	HOELTER .01
Default model	228	252
Independence model	5	5

Execution time summary

Minimization: ,094

Miscellaneous: 1,125

Bootstrap: ,000

Total: 1,219

Lampiran 8 Uji Sobel

Pengaruh Kompetensi terhadap kinerja laporan realisasi anggaran melalui pengendalian internal

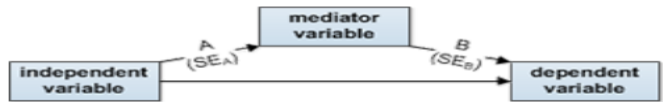

A: ?
 B: ?
 SE_A: ?
 SE_B: ?

Calculate!

Sobel test statistic: 4.11262961
One-tailed probability: 0.00001956
Two-tailed probability: 0.00003912

Pengaruh partisipasi anggaran terhadap kinerja laporan realisasi anggaran melalui pengendalian internal



A: ?
 B: ?
 SE_A: ?
 SE_B: ?

Calculate!

Sobel test statistic: 4.44539575
One-tailed probability: 0.00000439
Two-tailed probability: 0.00000877