

DAFTAR PUSTAKA

- Abdullah, H. (2017). PERANAN MANAJEMEN SUMBERDAYA MANUSIA DALAM ORGANISASI. *Jurnal Warta*.
- Adhan, M., Jufrizen, J., Prayogi, M. A., & Siswadi, Y. (2019). Peran Mediasi Komitmen Organisasi pada Pengaruh Kepuasan Kerja terhadap Kinerja Dosen Tetap Universitas Swasta di Kota Medan. *Jurnal Samudra Ekonomi Dan Bisnis*, 11(1). <https://doi.org/10.33059/jseb.v11i1.1654>
- Agoes, S. (2017). Auditing Petunjuk Praktis Pemeriksaan Akuntan oleh Akuntan Publik. In 1.
- Agustian, F. A., Poernomo, D., & Puspitaningtyas, Z. (2018). PENGARUH KOMPETENSI DAN KOMITMEN ORGANISASI TERHADAP KINERJA PEGAWAI. *Majalah Ilmiah DIAN ILMU*, 17(2). <https://doi.org/10.37849/midi.v17i2.83>
- AHMAD FAIZIN. (2021). *PENGARUH INTEGRITAS TERHADAP KINERJA KARYAWAN MELALUI VARIABEL LOYALITAS PADA KOPERASI PONDOK PESANTREN MANBAUL ULUM GRESIK*. UNIVERSITAS ISLAM NEGERI (UIN) MAULANA MALIK IBRAHIM.
- Alam, M. M., Johari, R. J., & Said, J. (2018). An empirical assessment of employee integrity in the public sector of Malaysia. *International Journal of Ethics and Systems*, 34(4). <https://doi.org/10.1108/IJOES-01-2018-0006>
- Algifari. (2015). *Analisis Regresi untuk Bisnis dan Ekonomi*.
- Alfredo, M. (2007). *Performance by Human Resource Management Handbook*,. Ohio University Press.
- Allen, N. J., & Meyer, J. P. (1990). The measurement and antecedents of affective, continuance and normative commitment to the organization. *Journal of Occupational Psychology*, 63(1). <https://doi.org/10.1111/j.2044-8325.1990.tb00506.x>
- Anwar, Anas Iswanto, 2002. Kajian Terhadap Penyaluran Kredit Perbankan Untuk Usaha Kecil dan Menengah (UKM) di Sulawesi Selatan, Kerjasama FE-Unhas dengan Bank Indonesia.
- Anwar, Anas Iswanto, et all. 2006, Perilaku dan Preferensi Masyarakat Sulawesi Selatan Terhadap Bank Perkreditan Rakyat (BPR)", Bank Indonesia.
- Anwar, Anas Iswanto. 2017, Bank dan Lembaga Keuangan Bukan Bank, Penerbit Departemen Ilmu Ekonomi FEB-Universitas Hasanudin.
- Anggoro P, R. A., Sufian, S., & Sugiarto PH, J. (2007). Strategi Membangun Kualitas Pelayanan Perbankan untuk Menciptakan Kepuasan Nasabah Berorientasi Loyalitas pada BRI Cabang Blora dan Unit online-nya. *Jurnal Studi Manajemen & Organisasi*, Vol 4 No 2(ISSN 1693-8283).
- Ansell, C., & Gash, A. (2008). Collaborative governance in theory and practice. *Journal of Public Administration Research and Theory*, 18(4). <https://doi.org/10.1093/jopart/mum032>
- Anwar, K., & Muhammad Havidz Aima. (2020). THE EFFECT OF COMPETENCE AND MOTIVATION ON ORGANIZATIONAL COMMITMENTS AND ITS IMPLICATIONS ON EMPLOYEE PERFORMANCE. *Dinasti International Journal of Education Management And Social Science*, 1(2), 183–196. <https://doi.org/10.31933/dijemss.v1i2.74>
- Arfah, S., Away, Y., & Tabrani, M. (2018). Pengaruh Komitmen, Integritas Dan Kompetensi Terhadap Kinerja Pegawai Serta Dampaknya Pada Kinerja

- Komisi Independen Pemilihan (KIP) Aceh,. *Jurnal Magister Manajemen*, 2(1), 58–67.
- Armstrong, M., & Baron, A. (2014). *Manajemen Kinerja* (R. Baru., Ed.). London: Institute of Personalia dan Pembangunan. Ambar Teguh.
- Ashfaq Ahmad, Hazrat Bilal, Palwasha Bibi, & Jawad Hussain. (2020). The Moderating Effect of Special Peer Support on the Relationship Between Remuneration and Employee Commitmen. *Journal of Accounting and Finance in Emerging Economies*, 6(4). <https://doi.org/10.26710/jafee.v6i4.1456>
- Awaludin, I., Ode, L., Adam, B., & Mahrani, S. W. (2016). The Effect of Job Satisfaction, Integrity and Motivation on Performance. *The International Journal Of Engineering And Science*, 5(1).
- Badaracco, J. L., & Ellsworth, R. R. (1991). Leadership, Integrity and Conflict. *Journal of Organizational Change Management*, 4(4). <https://doi.org/10.1108/EUM0000000001204>
- Bailey, A. A., Albassami, F., & Al-Meshal, S. (2016). The roles of employee job satisfaction and organizational commitment in the internal marketing-employee bank identification relationship. *International Journal of Bank Marketing*, 34(6). <https://doi.org/10.1108/IJBM-06-2015-0097>
- Barney, J. (1991). Firm Resources and Sustained Competitive Advantage. *Journal of Management*. <https://doi.org/10.1177/014920639101700108>
- Barney, J., Wright, M., & Ketchen, D. J. (2001). The resource-based view of the firm: Ten years after 1991. *Journal of Management*. [https://doi.org/10.1016/S0149-2063\(01\)00114-3](https://doi.org/10.1016/S0149-2063(01)00114-3)
- Bauman, D. C. (2013). Leadership and the three faces of integrity. *Leadership Quarterly*, 24(3). <https://doi.org/10.1016/j.leaqua.2013.01.005>
- Bedagama, F. M. H., & Tjahjaningsih, E. (2021). Bagaimana Komitmen Organisasional Memediasi Pengaruh Karakteristik Pekerjaan dan Employee Engagement terhadap Kinerja. *Telaah Bisnis*, 22(1). <https://doi.org/10.35917/tb.v22i1.209>
- Bingham, L. B. (2010). Collaborative Governance: Emerging Practices and the Incomplete Legal Framework for Citizen and Stakeholder Voice. *Missouri Journal of Dispute Resolution*, 2009(2).
- Blau, G. J. (1986). Job Involvement and Organizational Commitment as Interactive Predictors of Tardiness and Absenteeism. *Journal of Management*, 12(4). <https://doi.org/10.1177/014920638601200412>
- Bradley, Q. (2012). A “Performative” Social Movement: The Emergence of Collective Contentions within Collaborative Governance. *Space and Polity*, 16(2). <https://doi.org/10.1080/13562576.2012.721504>
- BRI. (n.d.). Laporan - Bank BRI | Melayani Dengan Setulus Hati. Retrieved January 15, 2021, from <https://bri.co.id/report>
- Caldwell, D. F., Chatman, J. A., & O'Reilly, C. A. (1990). Building organizational commitment: A multifirm study. *Journal of Occupational Psychology*, 63(3). <https://doi.org/10.1111/j.2044-8325.1990.tb00525.x>
- Case, A. (2003). *Transformational Leadership*. University at Buffalo.
- Chalistrya, Y. A., I Made Putrawan, & Supadi. (2020). THE EFFECT OF PERSONALITY AND INTEGRITY TO AFFECTIVE ORGANIZATIONAL COMMITMENT. *International Journal of Engineering Technologies and Management Research*, 6(1). <https://doi.org/10.29121/ijetmr.v6.i1.2019.348>
- Chughtai, A. A. (2008). Impact of Job Involvement on In-Role Job Performance

- and Organizational Citizenship Behaviour. *Journal of Behavioral and Applied Management*. <https://doi.org/10.21818/001c.17123>
- Clark, R., & Harrelson, G. L. (2002). Designing Instruction That Supports Cognitive Learning Processes. *Journal of Athletic Training*, 37(4 Suppl).
- Consensus-oriented decision-making: the CODM model for facilitating groups to widespread agreement. (2011). *Choice Reviews Online*, 49(04). <https://doi.org/10.5860/choice.49-2369>
- Covey, S. R. (1989). The 7 Habits of Highly Effective People: Powerful Lessons in Personal Change. *GetAbstract*. <https://doi.org/10.1099/mic.0.069922-0>
- Darmawan, P. (2018). EFFECT OF EMPLOYEE INTEGRITY AND FINANCIAL COMPENSATION TO EMPLOYEE PERFORMANCE IN EDUCATION AND EDUCATIONAL LEADERSHIP AT EAST JAVA PROVINCIAL TRAINING AND EDUCATION AGENC. *International Journal of Advanced Research*, 6(7), 335–340. <https://doi.org/https://doi.org/10.21474/ijar01/7366>
- Dave Ulrich. (1998). Intellectual Capital = Competence x Commitment. *Sloan Management Review*, 39(2).
- Dekker, H. C., Ding, R., & Groot, T. (2016). Collaborative performance management in interfirm relationships. *Journal of Management Accounting Research*, 28(3). <https://doi.org/10.2308/jmar-51492>
- Donald, Mc Eachern, T. (2007). *Competence of Personal in Prospective Theories*.
- Drs. Deliarnov. (2007). Ilmu pengetahuan Sosial ekonomi. *Ilmu Pengetahuan Sosial Ekonomi*, (September).
- Dubey, R., & Ali, S. S. (2011). Study on effect of functional competency on performance of indian manufacturing sector. *International Journal of Engineering Business Management*. <https://doi.org/10.5772/50941>
- Elbaz, A. M., Haddoud, M. Y., & Shehawy, Y. M. (2018). Nepotism, employees' competencies and firm performance in the tourism sector: A dual multivariate and Qualitative Comparative Analysis approach. *Tourism Management*, 67. <https://doi.org/10.1016/j.tourman.2018.01.002>
- Elsetouhi, A. M., Hammad, A. A., Nagm, A.-E. A., & Elbaz, A. M. (2018). Perceived leader behavioral integrity and employee voice in SMEs travel agents: The mediating role of empowering leader behaviors. *Tourism Management*, 65, 100–115. <https://doi.org/10.1016/j.tourman.2017.09.022>
- Emerson, K., & Nabatchi, T. (2015). Evaluating the productivity of collaborative governance regimes: A performance matrix. *Public Performance and Management Review*, 38(4). <https://doi.org/10.1080/15309576.2015.1031016>
- Emerson, K., Tina Nabatchi, & Nohrstedt, D. (Uppsala U. (2016). COLLABORATIVE GOVERNANCE REGIMES. *Public Administration*, Vol. 94(No. 4).
- Firdaus, V. (2021). Differences in the Performance of Permanent Employees and Contract Employees in the Furniture Industry. *JBMP (Jurnal Bisnis, Manajemen Dan Perbankan)*, 7(2). <https://doi.org/10.21070/jbmp.v7i2.1540>
- Fletcher, J. M. (2013). The effects of personality traits on adult labor market outcomes: Evidence from siblings. *Journal of Economic Behavior and Organization*, 89. <https://doi.org/10.1016/j.jebo.2013.02.004>
- Fu, W., & Deshpande, S. P. (2014). The Impact of Caring Climate, Job Satisfaction, and Organizational Commitment on Job Performance of Employees in a China's Insurance Company. *Journal of Business Ethics*,

- 124(2). <https://doi.org/10.1007/s10551-013-1876-y>
- Gibson, J. L., Ivancevich, J. M., & Donnelly, J. H. (1996). Organisasi : perilaku, struktur, proses. In 1. *KOMUNIKASI, Human communication: konteks-kontes komunikasi, buku kedua / Steward L. Tubbs dan Sylvia Moss; penerjemah Deddy Mulyana dan Gembirasari, editor Muchlis.*
- Govekar, P. L., & Nelly Trevinyo-Rodreguez, R. (2007). Integrity: A systems theory classification. *Journal of Management History*, 13(1). <https://doi.org/10.1108/17511340710715188>
- Greenberg, J., & Baron, R. A. (2003). Behavior in Organization Understanding and Managing the Human Side of Work. New Jersey: *Prentice-Hall Internasional.*
- Greenwood, S., Singer, L., & Willis, W. (2021). Collaborative governance: Principles, processes, and practical tools. In *Collaborative Governance: Principles, Processes, and Practical Tools.* <https://doi.org/10.4324/9781003172062>
- Grigoroudis, E., Tsitsiridi, E., & Zopounidis, C. (2013). Linking customer satisfaction, employee appraisal, and business performance: An evaluation methodology in the banking sector. *Annals of Operations Research.* <https://doi.org/10.1007/s10479-012-1206-2>
- Gross, R. (2016). Psychology The Science of Mind and Behaviour Seventh Edition. *Journal of Chemical Information and Modeling*, 53(9).
- Handayani, W. (2008). Dampak Komitmen Organisasi, Self Efficacy terhadap Konflik Peran dan Kinerja Karyawati PT. HM. Sampoerna Tbk. di Surabaya. *Jurnal Riset Ekonomi Dan Bisnis*, 8(2).
- Haritz, B., & Muliawaty, L. (2020). *Pengaruh Collaborative Governance Dan Koordinasi Terhadap Kinerja Organisasi Pada Proses Pembangunan Infrastruktur Untuk Kepentingan Umum Di Kota Bekasi.* Pasundan.
- Hasanuddin, R. (2010). *"Pengaruh Kompetensi dan Budaya Perusahaan terhadap Kompensasi, Kepuasan kerja, Komitmen dan Kinerja Karyawan Bank Sulsel.* Hasanuddin.
- I Ketut Suantra, Ni Wayan Sitiari, & Putu Ngurah Suyatna Yasa. (2020). The Role of Organizational Commitments Mediates The Effect of Competence on Employee Performance in PT. Bali Tangi Spa Production. *Jurnal Ekonomi & Bisnis JAGADITHA*, 7(1). <https://doi.org/10.22225/jj.7.1.1653.53-64>
- Ikatan Bankir Indonesia. (2014). Mengelola Kualitas Layanan Perbankan. (Jakarta: *PT Gramedia Pustaka Utama.*
- Irianto, G., & Baridwan, Z. (2015). The Effect of Working Experience, Integrity, Competence, and Organizational Commitment on Audit Quality (Survey State Owned Companies In Libya). *IOSR Journal of Economics and Finance Ver. II*, 6(4).
- Kaptein, M. (2003). The diamond of managerial integrity. *European Management Journal*, Vol. 21. [https://doi.org/10.1016/S0263-2373\(02\)00157-3](https://doi.org/10.1016/S0263-2373(02)00157-3)
- Kapucu, N., Yuldashev, F., & Bakiev, E. (2009). Collaborative Public Management and Collaborative Governance: Conceptual Similarities and Differences. *European Journal of Economic and Political Studies*, 2(1).
- Keraf, S. A. (1996). *Pasar bebas keadilan dan peran pemerintah telaah atas etika politik ekonomi Adam Smith* (Kanisius, Ed.). KOTA YOGYAKARTA: Kanisius.
- Killinger, B. (2007). Integrity: Doing the right thing for the right reason. In *Integrity:*

- Doing the Right Thing for the Right Reason.*
<https://doi.org/10.5860/choice.45-4080>
- Kim, H. R., Lee, M., Lee, H. T., & Kim, N. M. (2010). Corporate social responsibility and employee-company identification. *Journal of Business Ethics*, 95(4). <https://doi.org/10.1007/s10551-010-0440-2>
- Kolibáčová, G. (2014). The relationship between competency and performance. *Acta Universitatis Agriculturae et Silviculturae Mendelianae Brunensis*. <https://doi.org/10.11118/actaun201462061315>
- Kolthoff, E., Erakovich, R., & Lasthuizen, K. (2010). Comparative analysis of ethical leadership and ethical culture in local government: The USA, The Netherlands, Montenegro and Serbia. *International Journal of Public Sector Management*, 23(7). <https://doi.org/10.1108/09513551011078879>
- Krog, C. L., & Govender, K. (2015). The relationship between servant leadership and employee empowerment, commitment, trust and innovative behaviour: A project management perspective. *SA Journal of Human Resource Management*, 13(1). <https://doi.org/10.4102/sajhrm.v13i1.712>
- Lahat, L., & Sher-Hadar, N. (2020). A threefold perspective: conditions for collaborative governance. *Journal of Management and Governance*, 24(1). <https://doi.org/10.1007/s10997-019-09465-1>
- Lai, E. R. (2011). Collaboration : A Literature Review Research Report. *Research Reports*, (April).
- Leroy, H., Palanski, M. E., & Simons, T. (2012). Authentic Leadership and Behavioral Integrity as Drivers of Follower Commitment and Performance. *Journal of Business Ethics*, 107(3), 255–264. <https://doi.org/10.1007/s10551-011-1036-1>
- Lin, J. Y. (2019). How does collaboration between universities and R&D firms influence performance? *Management Decision*, 57(9). <https://doi.org/10.1108/MD-07-2016-0497>
- Loan, L. T. M. (2020). The influence of organizational commitment on employees' job performance: The mediating role of job satisfaction. *Management Science Letters*, 10(14). <https://doi.org/10.5267/j.msl.2020.6.007>
- Lu, C., & Yu, B. (2020). The effect of formal and informal external collaboration on innovation performance of smes: Evidence from China. *Sustainability (Switzerland)*, 12(22). <https://doi.org/10.3390/su12229636>
- Luthans, F. (2006). Perilaku Organisasi, Edisi Sepuluh. In *PT. Andi: Yogyakarta*.
- Luthans, F. (2012). Organizational behavior an evidence-based approach 12th edition. In *Organizational behavior: an edivence-based approach*.
- M. Nur Rianto al-arif. (2010). Dasar-dasar Pemasaran Bank Syariah. *Jurnal Ekonomi Dan Pembangunan*, 27(2).
- ManagementInstitute, P. (2017). A Guide To The Project Management Body of Knowledge PMBOK Guide Sixth Edition. In *Project Management Institute (Vol. 6)*.
- Manery, B. R., Lengkong, V. P. K., Saerang, R. T., & Komitmen....., P. (2018). PENGARUH KOMITMEN ORGANISASI DAN BUDAYA ORGANISASI TERHADAP KINERJA PEGAWAI DI BKDPSDA DI KABUPATEN HALMAHERA UTARA. *Jurnal EMBA : Jurnal Riset Ekonomi, Manajemen, Bisnis Dan Akuntansi*, 6(4).
- Mardiana, R., Guntur, Y., Haerani, S., & Hasan, M. (2012). The influence of affective, continuance and normative commitments on the turnover intentions of nurses at Makassar's private hospitals in Indonesia. *African*

- Journal of Business Management*, 6(38).
<https://doi.org/10.5897/AJBM11.1715>
- Mardiyana, I. K. E., & Riana, I. G. (2019). PERAN KOMITMEN ORGANISASIONAL DALAM MEMEDIASI PENGARUH KEPUASAN KERJA TERHADAP KINERJA KARYAWAN KRISNA OLEH - OLEH. *E-Jurnal Manajemen Universitas Udayana*, 8(11).
<https://doi.org/10.24843/ejmunud.2019.v08.i11.p22>
- Martini, I. A. O., Rahyuda, I. K., Sintaasih, D. K., & Piartrini, P. S. (2018). The Influence of Competency on Employee Performance through Organizational Commitment Dimension. *IOSR Journal of Business and Management (IOSR-JBM)*.
- Mata, F. J., Fuerst, W. L., & Barney, J. B. (1995). Information technology and sustained competitive advantage: A resource-based analysis. *MIS Quarterly: Management Information Systems*.
<https://doi.org/10.2307/249630>
- Mathis, R. L., & Jackson, J. H. (2006). *Human Resource Management*. Jakarta: Salemba Empat.
- McGregor, D. (2000). The Human Side of Enterprise. *Reflections: The SoL Journal*. <https://doi.org/10.1162/152417300569962>
- Meoqui, J. M. (2021). Overcoming absolute and comparative advantage: A reappraisal of the relative cheapness of foreign commodities as the basis of international trade. *Journal of the History of Economic Thought*, 43(3).
<https://doi.org/10.1017/S1053837220000401>
- Mitchell, G. E., O'Leary, R., & Gerard, C. (2015). Collaboration and performance: Perspectives from public managers and NGO leaders. *Public Performance and Management Review*, 38(4).
<https://doi.org/10.1080/15309576.2015.1031015>
- Morsink, C. V., Thomas, C. C., & Correra, V. I. (1991). *Interactive Teaming: Consultation and Collaboration in Special Programs. Second Edition*. New York, NY,: Mc Millan Publishn Company.
- MRI | Marketing Research Indonesia. (n.d.). Retrieved January 13, 2021, from <https://mri-research-ind.com/home/bsem/mriresearchindmarketingresearchindonesiamarketingresearchdiindonesiaperusahaanrisetdiindonesiarisetpasar>
- Muhammadiyah, K. B., Brasit, N., & Lasise, S. (2021). The Effect Of Person Job Fit And Training On Employee Performance Thorough Job Satisfaction At PT. PLN (Persero) UP3 Makasar Utara. *Journal Of Applied Business and Entrepreneurship (HJABE)*, 4(2), 2598–0890.
- Nelson, N. (2007). Human Resource Management In Strength Quality Prospective. *Journal of Business Research*, 60(3), 277–284.
- Ningrum, D., Haerani, S., & Munizu, M. (2020). The Effect of Intellectual Capital, Work Environment and Work Motivation of Behavior Organizational Citizenship and Employee Performance in PT. Japfa Comfeed Indonesia, Tbk Makassar Branch. *Hasanuddin Journal of Applied Business and Entrepreneurship*, 3(2). <https://doi.org/10.26487/hjabe.v3i2.321>
- Novianti, P. (2011). *Pengaruh Budaya Organisasi dan Kepuasan Kerja terhadap Komitmen Organisasi*. UIN Syarif Hidayatullah.
- Nurdin, S. (2013). *Pengaruh Gaya Kepemimpinan, Budaya Perusahaan, Kompetensi, Sistem dan Teknologi terhadap Kepuasan Kerja Komitmen Organisasi dan Kinerja Karyawan Bank Kaltim*. Hasanuddin University.

- Nwachukwu, P. I., & Sopirinye, E. (2019). *EMPLOYEE LOYALTY AND ORGANIZATIONAL COMMITMENT IN PORT HARCOURT ORGANIZATIONS NWACHUKWU PRECIOUS IKECHUKWU AND AMINOBIREN CHARLES . O. AND EPELLE , EZEKIEL SOPIRINYE AND KALU LIVINUS ACHI.*
- O'Reilly, C. A., Chatman, J., & Caldwell, D. F. (1991). PEOPLE AND ORGANIZATIONAL CULTURE: A PROFILE COMPARISON APPROACH TO ASSESSING PERSON-ORGANIZATION FIT. *Academy of Management Journal*, 34(3). <https://doi.org/10.5465/256404>
- Ordóñez de Pablos, P., & Lytras, M. D. (2008). Competencies and human resource management: Implications for organizational competitive advantage. *Journal of Knowledge Management*. <https://doi.org/10.1108/13673270810913612>
- Parung, J., & Bititci, U. S. (2006). A conceptual metric for managing collaborative networks. *Journal of Modelling in Management*, 1(2), 116–136. <https://doi.org/10.1108/17465660610703468>
- Pawirosumarto, S., Sarjana, P. K., & Gunawan, R. (2017). The effect of work environment, leadership style, and organizational culture towards job satisfaction and its implication towards employee performance in Parador hotels and resorts, Indonesia. *International Journal of Law and Management*. <https://doi.org/10.1108/IJLMA-10-2016-0085>
- Payangan, O. R. (Hasanuddin U. (2020). The Effect of Consumer Learning on Customer Loyalty A Study on BRI Customers in Southeast Sulawesi. *International Journal of Applied Behavioral Economics*, 0(1), 41–53. <https://doi.org/10.4018/IJABE.2020010104>
- Peterson, S. J., & Luthans, F. (2006). The impact of financial and nonfinancial incentives on business-unit outcomes over time. *Journal of Applied Psychology*. <https://doi.org/10.1037/0021-9010.91.1.156>
- Phillips, J. J. (1998). Measuring the return on investment in organization development: Key issues and trends. *Organization Development Journal*.
- Piazolo, D., & Förster, G. (2019). Integrity as performance-increasing factor within the real estate industry. *Property Management*, 37(1). <https://doi.org/10.1108/PM-02-2018-0015>
- Prasetyo, H. (2021). *PENGARUH KEPEMIMPINAN DAN INTEGRITAS TERHADAP KINERJA PEGAWAI DENGAN KOMITMEN ORGANISASI SEBAGAI VARIABEL INTERVENING (Studi Kasus pada Departemen Pengelolaan Uang Bank Indonesia)* (Mercu Buana University). Retrieved from <https://repository.mercubuana.ac.id/50427/>
- Princy, K., & Rebeka, E. (2019). Employee commitment on organizational performance. *International Journal of Recent Technology and Engineering*, 8(3), 891–895. <https://doi.org/10.35940/ijrte.C4078.098319>
- Purba, C. B. (2020). How is the impact of employee performance influenced by organizational commitment, integrity and leadership. *Academy of Entrepreneurship Journal*, 26(Special Issue 4), 1–10.
- Purnomo, R. (2017). Resource-Based View dan Keunggulan Bersaing Berkelanjutan : Sebuah Telaah Kritis Terhadap Pemikiran Jay Barney (1991). *Proceeding Seminar Nasional & Call For Papers (SCA-1)*.
- Purwati, A. A., & Wijaya, I. (2019). Pengaruh Kepemimpinan Transformasional, Integritas, Kompetensi, Dan Komitmen Organisasi Terhadap Kinerja Karyawan Di PT. Golden Riau Jaya Pekanbaru. *Jurnal Sains, Teknologi*

- Dan Industri*, 16(2). <https://doi.org/10.24014/sitekin.v16i2.10443>
- Rahim, N. A. A. B. A., Omar, K. B., & Kamaruddin, S. N. A. A. B. (2020a). Integrity and employee job performance. *Journal of Critical Reviews*, 7(16), 517–521. <https://doi.org/10.31838/jcr.07.16.62>
- Rahim, N. A. A. B. A., Omar, K. B., & Kamaruddin, S. N. A. A. B. (2020b). Integrity and employee job performance. *Journal of Critical Reviews*, 7(16). <https://doi.org/10.31838/jcr.07.16.62>
- Rahmat, M. A., Brasit, N., & Kadir, N. (2020). THE INFLUENCE OF LEADERSHIP STYLE AND WORK DISCIPLINE ON SERVICE QUALITY AND EMPLOYEE PERFORMANCE IN THE INVESTMENT OFFICE AND ONE STOP INTEGRATED SERVICE IN MAKASSAR CITY. *Hasanuddin Journal of Applied Business and Entrepreneurship*, 3(4), 58–71. <https://doi.org/10.26487/hjabe.v3i4.378>
- Rakhmanto, B., Masyhudzu Saluy, L., & Badawi, A. (2021). PENGARUH KEPEMIMPINAN DAN INTEGRITAS TERHADAP KINERJA ORGANISASI DENGAN KOMITMEN ORGANISASI SEBAGAI VARIABEL INTERVENING (STUDI KASUS PADA KOMISI PEMBERANTASAN KORUPSI). *Indikator*, 5(1). <https://doi.org/https://publikasi.mercubuana.ac.id/index.php/indikator/article/view/11239>
- Ranatiwi, M., & Mulyana, M. (2018). DAMPAK JEJARING KOLABORASI DAN KAPABILITAS INOVASI TERHADAP KINERJA. *Jurnal Ekonomi Dan Bisnis*, 19(1). <https://doi.org/10.30659/ekobis.19.1.49-58>
- Rita, M., Randa Payangan, O., Rante, Y., Tuhumena, R., & Erari, A. (2018). Moderating effect of organizational citizenship behavior on the effect of organizational commitment, transformational leadership and work motivation on employee performance. *International Journal of Law and Management*. <https://doi.org/10.1108/IJLMA-03-2017-0026>
- Robbins, S. P. (1994). Teori Organisasi: struktur, Desain dan Aplikasi. *Jakarta: Arcan*.
- Robbins, S. P., & Judge, T. (2013). *Organizational Behavior* (15th ed.). Pearson, 2013.
- Robbins, S. P., & Judge, T. A. (2008). Perilaku Organisasi Jilid II. *Salemba Empat*.
- Ronald Jacob Saleky, S., Cheng Wen, L., Randa Payangan, O., Jusni, J., & Pono, M. (2018). Identification of Customer Loyalty Determinants in Service Industry. *Journal of Business and Management Sciences*, 6(4). <https://doi.org/10.12691/jbms-6-4-5>
- Rosmi, R., & Syamsir, S. (2020). The Influence of Integrity and Work Experience on Employee Performance. *International Journal of Research and Analytical Reviews (IJRAR)*, 7(1).
- Rothwell, H. (2007). *Planning For Good Competence Individual*. Libraries Unlimited,.
- Rusydi, M., Muis, M., Mardiana, Ri. ((Hasanuddin U., & Idayanti. (2014). *PENGARUH KEPEMIMPINAN DAN PEMBERDAYAAN TERHADAP KOMPETENSI DAN PRESTASI KERJA DOSEN KOPERTIS WILAYAH IX DI KOTA MAKASSAR*. Hasanuddin University.
- Salman, M., Ganie, S. A., & Saleem, I. (2020). Employee Competencies as Predictors of Organizational Performance: A Study of Public and Private Sector Banks. *Management and Labour Studies*, 45(4), 416–432.

- <https://doi.org/10.1177/0258042X20939014>
- Saputri, E. D., & Muhsin, M. (2019). PERAN KOMITMEN ORGANISASI DALAM MEMEDIASI PENGARUH VARIABEL KETELADANAN PEMIMPIN, KOMPETENSI PERANGKAT DESA, DAN BUDAYA ORGANISASI TERHADAP KINERJA. *Economic Education Analysis Journal*, 7(3). <https://doi.org/10.15294/eeaj.v7i3.28345>
- Schunk, D. H. (2012). Learning theories: An educational perspective. In *Reading* (Vol. 5).
- Shahzadi, I., Sciences, B. (Hons) D. of M., The Islamia University of Bahawalpur, P., Javed, A., Sciences, B. (Hons) D. of M., The Islamia University of Bahawalpur, P., ... The Islamia University of Bahawalpur, P. (2014). Impact of Employee Motivation on Employee Performance. *European Journal of Business and Management*, 6(23). Retrieved from www.iiste.org
- Sihombing, S. O. (2018). Youth perceptions toward corruption and integrity: Indonesian context. *Kasetsart Journal of Social Sciences*, 39(2). <https://doi.org/10.1016/j.kjss.2018.03.004>
- Silvia, C. (2011). Collaborative Governance Concepts for Successful Network Leadership. *State and Local Government Review*, 43(1). <https://doi.org/10.1177/0160323x114400211>
- Sirait, M. M., Suratini, Husen, S., Rasyid, A., & Pasolo, F. (2020). Pengaruh Kompetensi Terhadap Kinerja Pegawai Dan Komitmen Organisasi Sebagai Variabel Mediasi (Studi Empirik Pada Kantor PT PLN (Persero) Unit Induk Wilayah Papua dann Papuan Barat). *The Journal Of Business and Management Research*, 3(2), 1–10. Retrieved from <http://jurnal1.uniyap.ac.id/uyp/index.php/tjbmr/article/view/14%0Ahttp://jurnal1.uniyap.ac.id/uyp/index.php/tjbmr/article/download/14/14>
- Solimun. (2017). Metode Statistika Multivariant. *Jurnal Pendidikan Ekonomi (JUPE)*.
- Song, M., Zhang, H., & Heng, J. (2020). Creating sustainable innovativeness through big data and big data analytics capability: From the perspective of the information processing theory. *Sustainability (Switzerland)*, 12(5). <https://doi.org/10.3390/su12051984>
- Spencer, M., & Spencer, J. (2019). 7. Competence and compellability. Special Measures. In *Evidence Concentrate*. <https://doi.org/10.1093/he/9780198840633.003.0007>
- Statsenko, L., & Corral de Zubielqui, G. (2020). Customer collaboration, service firms' diversification and innovation performance. *Industrial Marketing Management*, 85. <https://doi.org/10.1016/j.indmarman.2019.09.013>
- Sugiyanto, A. N. (2019). Mediasi Komitmen Organisasi Dalam Kepemimpinan Dan Budaya Organisasi Terhadap Kinerja Pegawai Akademi Pelayaran Nasional Surakarta. *EXCELLENT*, 6(1). <https://doi.org/10.36587/exc.v6i1.466>
- Sugiyono. (2015). Metode Penelitian. *Metode Penelitian*.
- Supriyanto, E. B. (2006). *Budaya Kerja Perbankan - Jalan Lurus Menuju Integritas*. Jakarta: LP3ES.
- Suyono, H., & , D. (2019). PENGARUH GAYA KEPEMIMPINAN SUPORTIF, KOMUNIKASI HORIZONTAL DAN PENGEMBANGAN KARIR TERHADAP KEPUASAN KERJA KARYAWAN KONTRAK (Studi Pada Karyawan Frontliner PT. Bank Central Asia Tbk Banjarmasin). *JWM (Jurnal Wawasan Manajemen)*, 7(1). <https://doi.org/10.20527/jwm.v7i1.177>

- Syarifuddin, S., Kadir, R., Maupa, H., & Muis, M. (2018). Pengaruh Resource Based View dan Dynamic Capability Terhadap daya Saing Strategis dan Kinerja Ekspor di Sulawesi-Selatan. *Disertasi*.
- Tasi, R., & Syamsir, S. (2020). The Influence Of Integrity And Loyalty on Employee Performance. *International Journal of Research and Analytical Reviews*, 7(1).
- Thierauf, F. (2008). *Perspective The Competency HRM*. New York, NY,: Harper and Row.
- Treviño, L. K., & Weaver, G. R. (2001). Organizational Justice and Ethics Program “Follow-Through”: Influences on Employees’ Harmful and Helpful Behavior. *Business Ethics Quarterly*, 11(4). <https://doi.org/10.2307/3857765>
- Trice, H. M., Mowday, R. T., Porter, L. W., & Steers, R. M. (1984). Employee-Organization Linkages: The Psychology of Commitment, Absenteeism, and Turnover. *Contemporary Sociology*, 13(1). <https://doi.org/10.2307/2068333>
- Tung, A., Baird, K., & Schoch, H. P. (2011). Factors influencing the effectiveness of performance measurement systems. *International Journal of Operations and Production Management*. <https://doi.org/10.1108/01443571111187457>
- Undang - Undang RI, B. I. (1992). Undang-Undang Nomor 7 Tahun 1992 Tentang Perbankan. *Bank Indonesia*.
- Verma, A., Mowday, R. T., Porter, L., & Steers, R. M. (1985). Employee-Organization Linkages: The Psychology of Commitment, Absenteeism and Turnover. *Industrial and Labor Relations Review*, 38(2). <https://doi.org/10.2307/2523856>
- Vogelgesang, G. R., Leroy, H., & Avolio, B. J. (2013). The mediating effects of leader integrity with transparency in communication and work engagement/performance. *The Leadership Quarterly*, 24(3), 405–413. <https://doi.org/10.1016/j.leaqua.2013.01.004>
- W. LaMorte MD, PhD, MPH, W. (2019). The social cognitive theory. *Boston University School of Public Health*, Vol. 12.
- Wahid, M., Salim, U., & Sudiro, A. (2017). TRANSFORMATIONAL LEADERSHIP STYLE AND COMPETENCY INFLUENCE ON EMPLOYEE PERFORMANCE: STUDY OF BNI MAKASSAR BRANCH. *Russian Journal of Agricultural and Socio-Economic Sciences*. <https://doi.org/10.18551/rjoas.2017-04.06>
- Walker, D. (2007). *Organization Behavior in Characteristic Qualified Prentice*. New Jersey: Hall Cliffs.
- Wernerfelt, B. (1984). A resource-based view of the firm. *Strategic Management Journal*. <https://doi.org/10.1002/smj.4250050207>
- Widodo. (2017). Metodologi Penelitian, Populer & Praktis. In *Metodologi Penelitian, Populer & Praktis*.
- Wright, P. M., McMahan, G. C., & McWilliams, A. (1994). Human resources and sustained competitive advantage: A resource-based perspective. *The International Journal of Human Resource Management*. <https://doi.org/10.1080/09585199400000020>
- Yamali, F. R. (2017). The Role Of Organizational Commitments Mediates The Effect Of Competence On Employee Performance. *Ekonomis: Jurnal of Economics and Business*, 1(1).
- Yoo, J., & Jung, Y. (2019). Interactive effects of organizational goal orientations on bank-employee’s behavior. *International Journal of Bank Marketing*. <https://doi.org/10.1108/IJBM-08-2017-0177>

- Yukl, G. (2009). Leading organizational learning: Reflections on theory and research. *Leadership Quarterly*.
<https://doi.org/10.1016/j.leaqua.2008.11.006>
- Yunus, A. N. M. T., Hamid, N., & Yusuf, R. M. (2018). Kepemimpinan dan Pengembangan Karir Terhadap Komitmen Organisasional Serta Dampaknya Pada Kinerja Karyawan PT. Bank Mandiri (Persero) TBK Area Makassar Kartini. *Hasanuddin Journal of Applied Business and Entrepreneurship (HJABE)*, 1(2), 50–60.
- Yunus, H. A., & Nawawi, W. (2013). *Teori Organisasi*. Majalengka: Universitas Majalengka.
- Yusril, B., Alam, S., & Pono, M. (2020). An Analysis of the Effect Compensation towards Employee Performance and Work Satisfaction of Employees of PT. Bank Rakyat Indonesia tbk. *Hasanuddin Journal of Applied Business and Entrepreneurship*, 3(4). <https://doi.org/10.26487/hjabe.v3i4.376>
- Zaim, H., Yasar, M. F., & Unal, O. F. (2013). analyzing the effects of individual competency on performance. *Journal of Global Strategic Management*.
- Zainal, V. R. (2015). Manajemen Sumber Daya Manusia. *Manajemen Sumber Daya Manusia Untuk Perusahaan Dari Teori Ke Praktik*.
- Ziafar, M., & Namaziandost, E. (2019). From Behaviorism to New Behaviorism: A Review Study. *Loquen: English Studies Journal*, 12(2).
<https://doi.org/10.32678/loquen.v12i2.2378>
- Zwell, M. (1999). Competencies distinguishing superior banks. *U.S. Banker*, 109.

Lampiran-lampiran

Lampiran 1 Kuesioner

KUESIONER

PENGARUH TATA KELOLA KOLABORASI, KOMPETENSI PERSONAL DAN INTEGRITAS TERHADAP KINERJA KARYAWAN MELALUI KOMITMEN ORGANISASI PADA BANK BRI DI SULAWESI SELATAN

Dengan Hormat,

Dalam rangka penulisan disertasi pada Program Studi Doktor Ilmu Ekonomi Fakultas Universitas Hasanuddin, maka saya mohon kepada Bapak/Ibu/Sdr. untuk mengisi kuesioner yang telah disediakan.

Angket ini bukan tes psikologi dari atasan atau darimanapun, serta bersifat rahasia sehingga Bapak/Ibu/Sdr. tidak perlu takut atau ragu-ragu dalam memberikan jawaban yang sejujurnya. Artinya semua jawaban yang diberikan adalah benar dan jawaban yang diminta adalah sesuai dengan kondisi yang dirasakan oleh Bapak/Ibu/Sdr. selama ini. Hasil studi ini diharapkan dapat memberikan kontribusi sebagai bahan masukan bagi Bank BUMN khususnya Bank BRI Kanwil Makassar dalam merumuskan kebijakan terkait dengan Tata Kelola Kolaborasi, kompetensi, integritas dan komitmen organisasi serta pengaruhnya terhadap kinerja karyawan untuk meningkatkan kinerja pelayanan terhadap nasabah..

Setiap jawaban yang diberikan merupakan bantuan yang tidak ternilai harganya bagi penelitian ini, atas perhatian dan bantuannya, saya mengucapkan terima kasih.

Makassar, Januari 2022

Peneliti,

Ichwan Riodini

Semua pernyataan di bawah ini menyangkut tanggapan anda mengenai pengaruh Tata Kelola Kolaborasi, Kompetensi Personal dan Integritas terhadap Kinerja Karyawan melalui Komitmen Organisasi pada Bank BRI di Sulawesi Selatan

IDENTITAS RESPONDEN

1. Nama :
(boleh tidak diisi)
2. Kantor Cabang / Unit :
3. Posisi / Jabatan :
4. Kabupaten/Kota :
5. No. HP :
(boleh tidak diisi)
6. Jenis Kelamin :
 Laki-laki
 Perempuan
7. Umur :
 < 25 tahun
 26 – 39 tahun
 40 – 49 tahun
 > 50 tahun
8. Pendidikan terakhir :
 Diploma
 Sarjana (S1)
 Master (S2)
9. Masa kerja :
 2 – 3 tahun
 3,1 – 4 tahun
 Diatas 5 tahun
10. Status Perkawinan :
 Kawin
 Belum Kawin

11. Status Pegawai :

- Pegawai Tetap
- Pegawai Kontrak
- Pegawai *Outsource*
- Magang

Petunjuk :

Pilihlah salah satu jawaban yang Anda anggap paling sesuai dengan diri Anda dengan memberi tanda (X) pada jawaban yang dipilih.

Pilihan jawaban :	Nilai
a. Sangat setuju	: 5
b. Setuju	: 4
c. Netral	: 3
d. Tidak setuju	: 2
e. Sangat tidak setuju	: 1

PERNYATAAN :

A. Tata kelola Kolaborasi (*Collaborative Governance*)

Suatu sistem tata kelola yang dilakukan dalam usaha untuk meningkatkan kinerja pelayanan secara kolektif dengan menggunakan forum kolaborasi (kerja sama) yang diselenggarakan secara resmi untuk melakukan pertemuan dan dialog secara teratur dalam rangka membuat keputusan serta implementasinya dengan cara musyawarah dan mufakat. Sistem ini dilaksanakan melibatkan manajemen serta non-manajemen (pelaku kolaborasi) yang berasal dari beberapa sektor yang berbeda (*frontliner*, divisi penunjang, *marketing*, *supervisor*) dengan posisi setara dan otonom.

No	Daftar Pernyataan	Jawaban				
		STS	TS	N	S	SS
1.	Kondisi Awal					
	a. Dibandingkan dengan administrasi publik yang tradisional, tata kelola kolaborasi dapat lebih baik dalam meningkatkan kinerja pelayanan					
	b. Tata kelola kolaborasi diperlukan dalam meningkatkan kinerja pelayanan karena adanya ketidakseimbangan sumber daya dan pengetahuan diantara para pelaku kerjasama					
	c. Tata kelola kolaborasi diperlukan karena kurang maksimalnya kerjasama yang telah dilakukan sebelumnya serta adanya konflik-konflik yang pernah terjadi antara para pelaku kerja sama					

No	Daftar Pernyataan	Jawaban				
		STS	TS	N	S	SS
	d. Tata kelola kolaborasi diperlukan karena bentuk dorongan serta banyaknya kendala untuk berpartisipasi diantara para pelaku kolaborasi					
	e. Dalam tata kelola kolaborasi perlu dipersiapkan kondisi-kondisi diantara para pelaku sehingga terhindar dari konflik					
	f. Tata kelola kolaborasi antara semua pelaku dapat meningkatkan kinerja pelayanan					
2.	Desain Institusi					
	a. Saya perlu mengetahui aturan main dan bentuk pelaksanaan yang jelas supaya dapat ikut berpartisipasi dalam tata kelola kolaborasi dan implementasinya					
	b. Perusahaan perlu membuat konsep yang jelas dan transparan dalam tata kelola kolaborasi serta implementasinya					
	c. Dalam proses implementasi tata kelola kolaborasi perlu adanya transparansi dalam masalah insentif					
	d. Perusahaan perlu menciptakan aturan main yang jelas dan adil dalam melaksanakan tata kelola kolaborasi					
	e. Perusahaan perlu menjelaskan rencana pembentukan tata kelola kolaborasi ke semua pihak					
3.	Kepemimpinan Fasilitatif					
	a. Pemimpin harus dapat diterima dan dipercaya oleh para pelaku kerjasama					
	b. Pemimpin dapat diandalkan sebagai mediator di dalam tata kelola kolaborasi.					
	c. Pemimpin dapat menyediakan semua yang dibutuhkan para pelaku kolaborasi					
	d. Pemimpin harus adil dalam proses kolaborasi kepada semua pihak					
	e. Pelaksanaan tata kelola kolaborasi sama mengedepankan demokrasi, kesetaraan dan otonomi					
4	Proses Kolaborasi					
	a. Tata kelola kolaborasi dimulai dari dialog tatap muka yang biasanya dilakukan untuk mengidentifikasi peluang akan adanya keadaan "saling menguntungkan" terhadap para pelaku.					
	b. Tata kelola kolaborasi harus mampu membangun kepercayaan dan komitmen diantara para pelaku dan pihak terkait					
	c. Para pelaku tata kelola kolaborasi harus mampu mengembangkan pemahaman bersama tentang apa yang dapat dicapai					

No	Daftar Pernyataan	Jawaban				
		STS	TS	N	S	SS
	d. Para pelaku tata kelola kolaborasi saling berbagi pemahaman tentang misi dan permasalahan serta mengidentifikasi nilai-nilai umum dalam bekerja sama					
	e. Semua pihak pelaku tata kelola kolaborasi terlibat dalam pengambilan keputusan secara msyawah					

Pertanyaan Terbuka

1. Saran saya terhadap penerapan tata kelola kerjasama :
2. Harapan terhadap penerapan tata kelola kerjasama dalam rangka peningkatan kinerja pelayanan

B. Kompetensi Personal

Kemampuan kerja setiap individu yang mencakup aspek pengetahuan, keterampilan, dan sikap kerja yang sesuai dengan standardisasi yang diharapkan

No	Daftar Pernyataan	Jawaban				
		STS	TS	N	S	SS
1	Pengetahuan (<i>knowledge</i>)					
	a. Pengetahuan saya dapat menunjang kemampuan saya dalam bekerja					
	b. Saya mencari referensi tambahan, baik dari internet yang berkaitan dengan pekerjaan saya					
	c. Saya mengetahui apa yang harus saya lakukan untuk menjadi sukses ditempat kerja					
	d. Perusahaan memberi saya fasilitas yang memadai untuk memperluas pengetahuan saya					
	e. Saya senang bila perusahaan dapat terus menunjang peningkatan pengetahuan saya					
2.	Keterampilan (<i>skill</i>)					
	a. Keterampilan yang dimiliki sesuai dengan teknis pekerjaan yang dikerjakan					
	b. Pelatihan yang diberikan dapat meningkatkan keterampilan dan mempermudah menyelesaikan pekerjaan					
	c. Saya mampu memberikan umpan balik tentang permasalahan yang saya ketahui					
	d. Perusahaan memfasilitasi saya untuk dapat menambah dan mengembangkan keterampilan saya					
	e. Saya mempunyai banyak keterampilan diluar pekerjaan saya namun bermanfaat buat kinerja saya					
3.	Pengalaman Kerja					
	a. Karyawan yang menunjukkan pengalaman dan keahlian dipromosikan pada jabatan tertentu					
	b. Karyawan yang senior lebih berpengalaman dan mempunyai keahlian dalam bekerja					
	c. Karyawan yang mempunyai pengalaman dan Keahlian yang dimiliki merupakan kebanggaan diri setiap karyawan.					

No	Daftar Pernyataan	Jawaban				
		STS	TS	N	S	SS
	d. Pengalaman kerja sangat berguna dalam meningkatkan kinerja karyawan					
	e. Saya diberi kesempatan untuk berkembang di berbagai posisi pekerjaan					
4.	Pendidikan					
	a. Pendidikan formal saya dapat menunjang kemampuan saya dalam bekerja					
	b. Pendidikan yang saya miliki sesuai dengan teknis pekerjaan yang diberikan					
	c. Pendidikan formal saya menunjang kesempatan saya dalam berkarir					
	d. Perusahaan terus mendorong saya untuk dapat pendidikan yang lebih baik					
	e. Perusahaan menghargai hak saya dalam mencapai pendidikan yang lebih tinggi					

Pertanyaan Terbuka

1. Saran saya untuk peningkatan kompetensi bagi para karyawan dalam rangka meningkatkan kinerja pelayanan:
2. Harapan saya terhadap peningkatan kompetensi personal di masa yang akan datang

C. Integritas

Karakteristik atau kualitas perilaku individu atau organisasi yang mencerminkan kualitas bertindak sesuai dengan standar, aturan dan nilai-nilai moral yang ditetapkan oleh suatu organisasi maupun oleh masyarakat

No	Daftar Pernyataan	Jawaban				
		STS	TS	N	S	SS
1.	Jujur					
	a. Saya selalu mengutamakan perilaku kejujuran dalam menjalankan pekerjaan					
	b. Dalam bekerja saya selalu memiliki kejujuran terhadap diri sendiri, teman dan pimpinan					
	c. Saya selalu berusaha untuk tidak berbohong					
	d. Saya berusaha untuk menghindari kecurangan					
	e. Saya melakukan pekerjaan saya sebaik-baiknya					
2.	Truthfulness					
	a. Saya selalu melakukan hal yang benar dalam menjalankan pekerjaan					
	b. Dalam bekerja saya selalu mengutamakan moral dan kebenaran					
	c. Saya mengikuti semua aturan serta SOP yang dikeluarkan perusahaan					
	d. Saya berusaha untuk berbuat yang benar walaupun tanpa pengawasan					
	e. Saya menghindari setiap perilaku yang melanggar norma-norma agama, norma adat serta norma masyarakat					
3	Konsistensi perkataan dan Perbuatan					
	a. Saya selalu melaksanakan apa yang saya katakan					

No	Daftar Pernyataan	Jawaban				
		STS	TS	N	S	SS
	b. Saya tidak akan mengingkari janji aaya					
	c. Saya berusaha untuk menepati janji saya kepada siapapun					
	d. Saya tidak akan melanggar janji saya sebagai seorang pegawai					
	e. Saya akan melaksanakan aturan dan kebijakan perusahaan yang telah diberikan kepada saya					

Pertanyaan Terbuka

1. Saran saya untuk peningkatan integritas bagi para karyawan dalam rangka meningkatkan kinerja pelayanan:
2. Harapan saya terhadap peningkatan integritas personal di masa yang akan datang

D. Komitmen Organisasi

Suatu keadaan dimana seorang karyawan memihak organisasi tertentu serta tujuan-tujuan dan keinginannya untuk mempertahankan keanggotaan dalam organisasi tersebut

No	Daftar Pernyataan	Jawaban				
		STS	TS	N	S	SS
1.	Rasa bangga					
	a. Saya merasa sangat bangga bekerja di perusahaan ini					
	b. Perusahaan ini memberikan yang terbaik buat saya					
	c. Saya membanggakan perusahaan ini kepada orang diluar perusahaan ini					
	d. Bagi saya perusahaan ini merupakan yang terbaik					
	e. Perusahaan ini lebih baik dibandingkan dengan perusahaan lain yang sejenisnya					
2.	Loyalitas					
	a. Saya merasa menjadi bagian dari keluarga besar perusahaan ini					
	b. Akan terlalu merugikan saya untuk meninggalkan Bank ini					
	c. Jika saya mendapatkan tawaran pekerjaan yang lebih baik di tempat lain maka saya merasa tawaran tersebut bukan merupakan alasan yang tepat untuk meninggalkan bank ini					
	d. Saya mengeluarkan segala kemampuan saya dalam bekerja di perusahaan ini					
	e. Saya rela berkorban waktu dan tenaga saya untuk membesarkan perusahaan ini					
3.	Perhatian terhadap keberlangsungan perusahaan					
	a. Saya ingin perusahaan ini semakin maju					
	b. Saya percaya loyalitas adalah penting dan saya merasa tetap bekerja di bank ini merupakan kewajiban moral					

No	Daftar Pernyataan	Jawaban				
		STS	TS	N	S	SS
	c. Saya merasa terikat secara emosional terhadap perusahaan ini					
	d. Saya harus membalas kebaikan perusahaan ini terhadap saya					
	e. Saya turut andil dalam membesarkan perusahaan ini					
4.	Pekerjaan yang memberikan inspirasi					
	a. Saya senang dapat berkerja di perusahaan ini					
	b. Saya suka pekerjaan yang diberikan kepada saya					
	c. Saya saat ini tetap bekerja di perusahaan ini merupakan kebutuhan sekaligus juga keinginan saya					
	d. Perusahaan ini telah membuat kehidupan saya menjadi lebih baik					
	e. Saya rela mengeluarkan kemampuan saya secara maksimal demi perusahaan ini					
5.	Kesempatan berkarir					
	a. Saya akan merasa bahagia menghabiskan sisa karir saya di perusahaan ini					
	b. Perusahaan selalu mendukung pegawai yang berprestasi dalam bekerja					
	c. Saya mempunyai harapa untuk dapat lebih berkembang di masa depan dengan perusahaan ini					
	d. Perusahaan ini selalu memperhatikan karyawannya yang loyal dan berprestasi					
	e. Perusahaan menghargai kinerja serta segala pengorbanan saya terhadap perusahaan					

Pertanyaan Terbuka

1. Saran saya untuk peningkatan komitmen bagi para karyawan dalam rangka meningkatkan kinerja pelayanan:
2. Harapan saya terhadap peningkatan komitmen di masa yang akan datang

E. Kinerja karyawan

Hasil kerja yang dicapai oleh seorang karyawan dalam melaksanakan tugas dan pekerjaan sesuai tanggungjawab dan wewenang yang diberikan kepadanya mencakup kuantitas, kualitas dan efisiensi

No	Daftar Pernyataan	Jawaban				
		STS	TS	N	S	SS
1.	Kuantitas Hasil Kerja					
	a. Saya selalu berhasil mencapai standar kualitas kerja yang telah ditetapkan perusahaan.					
	b. Hasil kerja saya sesuai dengan target yang telah ditetapkan perusahaan					
	c. Saya selalu berusaha meningkatkan kinerja saya dalam bekerja					
	d. Saya selalu tertarik untuk mengetahui detil pekerjaan pada divisi lainnya					
	e. Saat pekerjaan saya selesai, saya berminat membantu pekerjaan teman lain yang belum selesai					
2.	Kualitas Hasil Kerja					
	a. Hasil Kerja saya sesuai dengan standar kualitas atau mutu yang ditetapkan oleh perusahaan.					

	b. Dalam bekerja, saya selalu merencanakan pekerjaan saya					
	c. Saya selalu mencari jalan agar dapat melakukan pekerjaan sebaik-baiknya					
	d. Saya selalu berusaha untuk terus memperbaiki kualitas pekerjaan saya					
	e. Saya telah berkerja semaksimal mungkin					
3.	Efisiensi					
	a. Saya melakukan pekerjaan saya secara efektif dan efisien					
	b. Saya selalu bekerja hati-hati dan cermat untuk menghindari kesalahan					
	c. Saya selalu mencari jalan agar dapat melakukan pekerjaan dengan lebih efisien					
	d. Saya menghindari penggunaan sumber daya perusahaan yang terlalu berlebihan					
	e. Saya selalu berusaha agar pekerjaan saya tepat sasaran sesuai keinginan perusahaan					

Pertanyaan Terbuka

1. Saran saya untuk peningkatan kinerja karyawan dalam rangka meningkatkan kinerja pelayanan:
2. Harapan saya untuk peningkatan kinerja karyawan di masa yang akan datang

Lampiran 2 Data Rekap Jawaban Responden

1. Tata Kelola Kolaborasi

No.	Tata Kelola Kolaborasi																				
	X1.11	X1.12	X1.13	X1.14	X1.15	X1.16	X1.21	X1.22	X1.23	X1.24	X1.25	X1.31	X1.32	X1.33	X1.34	X1.35	X1.41	X1.42	X1.43	X1.44	X1.45
1	5	5	5	5	5	5	5	4	4	4	4	4	4	4	5	5	5	5	5	4	4
2	5	4	5	5	5	5	5	4	4	4	5	4	4	4	5	5	5	5	4	4	4
3	4	4	4	5	4	4	5	5	5	5	5	4	4	4	5	5	4	4	4	5	5
4	5	5	5	5	5	5	5	5	5	5	5	5	5	5	5	5	5	5	5	5	5
5	5	5	5	4	5	5	4	4	4	4	5	4	4	4	5	5	5	4	4	4	5
6	5	5	5	5	5	5	5	5	5	5	5	5	5	5	5	5	5	5	5	5	5
7	5	4	5	5	5	5	4	4	4	5	5	4	4	4	5	5	5	4	4	4	5
8	5	5	4	4	4	4	5	5	5	5	5	5	5	5	5	5	5	5	5	5	5
9	3	4	5	4	5	5	5	4	4	4	4	4	4	4	5	5	5	4	4	4	4
10	3	5	3	3	3	3	5	5	4	4	4	4	4	4	5	5	4	4	2	3	2
11	3	3	4	4	3	3	3	3	3	4	4	4	4	3	3	3	5	4	4	4	5
12	4	5	4	5	4	4	5	5	5	5	5	5	5	5	5	5	5	5	5	5	5
13	3	3	4	4	3	3	5	4	4	4	4	4	4	3	3	3	5	4	4	4	4
14	5	5	3	4	4	4	4	4	5	4	5	4	4	4	5	5	5	4	4	4	5
15	5	4	5	4	4	4	3	4	3	3	4	4	4	4	5	5	4	4	2	3	2
16	5	5	5	5	5	5	5	5	5	5	5	5	5	5	5	5	5	5	5	5	5
17	3	3	3	3	4	4	4	4	4	5	5	3	3	3	4	4	4	4	4	5	5
18	5	4	4	4	4	4	3	3	3	4	4	4	4	4	5	5	4	4	2	3	2
19	3	4	5	4	5	5	5	5	5	5	5	4	4	4	5	5	5	4	5	5	5
20	5	5	3	4	4	4	4	3	3	4	3	4	4	4	5	5	3	3	3	4	4
21	3	3	5	3	3	3	5	4	4	4	4	4	4	3	3	3	5	4	4	4	4
22	5	5	4	4	4	4	5	5	5	5	5	5	5	5	5	5	5	4	4	4	5
23	5	5	3	4	4	4	4	4	5	4	5	5	5	4	5	5	5	4	4	4	5
24	5	5	3	4	4	4	4	4	4	4	5	4	4	3	3	3	5	4	4	4	5
25	3	3	3	3	4	4	3	3	3	4	4	4	4	4	5	5	4	5	2	3	2
26	5	4	5	5	4	3	3	3	3	4	4	4	4	4	5	5	4	4	4	5	5
27	3	3	3	5	3	3	3	4	3	3	4	4	4	3	3	3	4	5	2	3	2
28	3	4	5	4	5	5	2	3	3	5	4	4	4	3	3	3	5	4	4	4	4
29	5	5	3	4	4	4	4	4	4	4	5	4	4	4	5	5	4	4	4	4	5
30	3	4	5	4	5	5	5	2	3	3	4	4	4	3	3	3	3	5	4	2	3
31	2	2	2	4	2	2	1	2	2	3	4	5	3	2	1	1	3	2	2	2	2
32	2	2	2	2	2	4	3	3	2	2	2	1	5	2	3	1	3	1	2	2	4
33	5	3	3	3	3	3	3	3	3	4	4	4	4	3	3	3	4	4	3	3	2
34	4	4	3	3	3	3	3	3	2	2	2	2	3	1	1	5	1	4	2	2	3
35	2	2	2	2	2	4	3	3	2	2	2	1	3	2	2	2	3	1	2	2	4
36	3	3	3	3	3	4	4	3	3	3	4	4	4	3	3	3	3	2	3	4	5
37	3	3	2	2	2	2	1	1	1	2	2	1	1	1	3	1	1	2	1	1	2
38	3	3	2	2	2	2	1	2	1	1	1	2	1	1	1	1	2	1	2	1	1
39	5	5	4	4	4	4	5	5	5	5	5	5	5	5	5	5	5	5	5	5	5
40	5	5	3	4	4	4	4	4	4	4	5	5	5	5	4	4	5	4	4	4	5
41	5	5	5	5	5	5	5	5	5	5	5	5	5	5	5	5	5	5	5	5	5
42	5	5	4	4	4	4	5	5	5	5	5	4	5	5	4	4	5	4	4	4	5
43	5	5	4	4	4	4	4	4	5	5	5	5	5	5	5	5	5	5	5	5	5
44	5	4	5	4	5	5	5	5	4	4	5	5	5	5	5	5	5	5	4	5	4
45	5	5	4	4	4	4	5	5	5	5	5	4	4	4	5	5	5	4	4	4	5
46	5	5	4	4	4	4	5	5	5	5	5	5	5	5	5	5	5	5	5	5	5
47	3	4	5	4	5	5	5	4	5	5	4	4	4	4	5	5	5	4	4	4	4
48	5	5	3	4	4	4	5	4	4	5	4	5	4	5	4	4	5	4	4	4	5
49	3	4	5	4	5	5	4	5	2	3	3	4	4	3	3	3	3	5	4	3	2
50	4	4	3	3	3	3	3	3	3	4	4	4	5	5	4	4	4	4	4	5	5
51	4	4	3	3	3	3	4	3	3	3	4	4	4	3	3	3	4	4	4	5	5
52	5	5	3	4	4	4	5	4	4	4	5	4	5	5	4	4	5	4	4	4	5
53	4	4	3	3	3	3	3	3	3	4	4	4	4	3	3	3	4	2	2	3	5
54	4	4	3	3	3	3	3	3	3	4	4	4	5	5	4	4	4	2	2	3	5
55	3	3	2	2	2	2	3	3	3	4	4	2	3	4	2	1	5	4	1	1	1
56	4	4	3	3	3	3	3	3	3	2	4	2	3	2	4	5	5	4	2	2	3
57	3	3	2	2	2	2	3	3	2	2	2	5	3	1	1	2	3	1	2	2	2
58	4	4	3	3	3	3	4	3	2	2	1	2	4	2	1	3	1	4	2	2	3
59	5	5	3	4	4	4	5	5	5	4	5	4	4	4	5	5	5	4	4	4	5
60	5	5	5	5	5	5	5	5	5	5	5	5	5	5	5	5	5	5	5	5	5
61	5	5	4	4	4	4	5	5	5	5	5	4	4	4	5	5	5	4	4	4	5
62	5	5	5	5	5	5	5	5	5	5	5	5	5	5	5	5	5	5	5	5	5
63	3	3	2	2	2	2	3	3	2	2	2	2	3	5	1	1	4	1	1	2	2
64	3	3	2	2	2	2	1	1	1	2	2	2	1	2	1	1	1	2	3	2	2
65	1	1	2	1	1	1	2	2	2	3	3	2	2	1	1	1	1	2	2	1	1
66	3	3	2	2	2	2	2	2	2	3	3	1	1	2	1	2	1	2	2	1	1
67	4	4	3	3	3	3	3	3	3	4	4	4	4	4	5	5	4	4	4	5	5
68	4	4	3	3	3	3	3	3	2	5	4	3	3	4	3	4	5	4	2	3	2
69	5	5	4	4	4	4	5	4	4	4	5	4	4	4	5	5	5	4	4	4	5
70	3	4	3	3	3	3	4	5	2	3	3	4	4	4	5	5	2	4	4	3	4
71	5	5	4	4	4	4	5	4	4	4	5	4	5	5	4	4	4	4	4	5	5
72	3	4	5	4	5	5	5	4	4	4	4	4	5	5	4	4	5	4	4	4	4
73	3	3	3	3	3	4	3	4	2	4	4	4	4	4	5	5	3	4	4	3	2
74	3	3	3	3	3	4	5	4	4	4	4	4	4	4	5	5	5	4	4	4	4
75	3	3	3	3	3	3	2	3	3	5	4	3	3	3	4	4	3	4	4	3	2
76	3	3	3	3	3	3	5	4	4	4	4	3	3	3	4	4	3	5	4	3	2
77	5	5	4	4	4	4	5	4	4	4	5	5	5	5	5	5	5	4	4	4	5
78	5	5	4	4	4	4	5	4	4	4	5	4	4	4	5	5	5	5	4	4	4
79	5	5	4	4	4	4	5	4	4	4	5	4	4	4	5	5	5	4	4	4	5
80	4	4	3	3	3	3	3	2	3	4	4	3	4	3	4	3	4	4	4	5	5
81	4	4	3	3	3	3	3	2	4	4	4	4	3	3	3	4	1	4	2	5	3
82	5	5	3	4	4	4	5	4	4	4	5	4	4	4	5	5	5	4	4	4	5
83	5	4	5	4	5	5	5	4	4	4	4	4	4	4	5	5	5	4	4	4	4
84	3	3	2	2	2	2	2	1	1	1	2	2	2	1	1	1	3	4	2	1	2

No.	Tata Kelola Kolaborasi																				
	X1.11	X1.12	X1.13	X1.14	X1.15	X1.16	X1.21	X1.22	X1.23	X1.24	X1.25	X1.31	X1.32	X1.33	X1.34	X1.35	X1.41	X1.42	X1.43	X1.44	X1.45
85	3	3	2	2	2	2	3	3	2	2	2	5	3	1	2	1	3	4	2	1	2
86	1	2	2	1	1	1	1	2	1	1	2	2	2	2	1	1	2	3	2	1	4
87	3	3	3	3	4	3	5	4	4	4	4	3	3	3	4	4	3	4	4	3	2
88	5	5	4	4	4	4	5	4	4	4	5	4	5	5	4	4	5	5	4	4	4
89	5	5	5	5	4	4	5	5	5	4	5	5	5	4	5	5	5	4	5	5	5
90	5	5	4	4	4	4	2	3	3	4	4	4	5	5	4	4	5	4	5	4	4
91	4	4	3	3	3	3	3	3	2	4	4	4	5	2	1	4	5	4	2	3	3
92	5	5	4	4	4	4	5	4	4	4	5	4	5	5	4	4	5	4	4	4	5
93	3	4	5	4	5	5	5	4	4	4	4	4	5	5	4	4	5	4	4	4	4
94	4	4	3	3	3	3	3	3	3	4	4	3	3	3	4	4	5	4	2	3	3
95	3	3	3	3	4	4	3	3	3	3	4	3	3	3	4	4	5	4	4	4	4
96	5	5	4	4	4	4	5	4	4	4	5	4	5	5	4	4	5	4	4	4	5
97	3	4	5	4	5	5	5	4	4	4	4	4	5	5	4	4	5	4	4	4	4
98	5	5	3	4	4	4	5	4	4	4	5	4	5	5	4	4	5	4	4	4	5
99	5	5	3	4	4	4	3	3	3	4	4	3	3	3	4	4	3	4	4	4	2
100	5	5	4	4	4	4	4	5	2	2	4	3	3	3	4	4	5	4	2	3	3
101	5	5	4	4	4	4	3	3	3	4	4	3	3	3	4	4	5	4	2	2	3
102	5	5	3	4	4	4	3	2	3	4	4	3	3	3	4	4	3	5	4	3	2
103	5	5	4	4	4	4	3	3	3	4	4	3	3	3	4	4	5	4	2	3	3
104	5	5	4	4	4	4	3	3	2	4	4	3	3	3	4	4	5	4	2	3	3
105	5	5	4	4	4	4	3	3	3	4	4	5	2	1	4	4	5	4	2	2	3
106	5	5	4	4	4	4	5	4	4	4	5	4	5	5	4	4	5	5	4	4	4
107	5	5	3	4	4	4	3	2	3	4	4	4	5	2	2	4	3	4	4	3	2
108	5	5	4	4	4	4	3	2	3	4	4	4	5	2	2	4	5	4	2	3	3
109	3	3	3	4	3	3	3	3	3	4	4	4	4	5	2	1	4	3	4	4	2
110	5	5	4	4	4	4	5	4	4	4	5	4	5	5	4	4	5	5	4	4	4
111	4	4	3	3	3	3	3	2	4	4	4	4	5	2	2	4	5	4	2	1	3
112	3	4	5	4	5	5	5	4	4	4	4	4	5	5	4	4	5	4	4	4	4
113	5	5	4	4	4	4	3	3	3	4	4	3	3	3	4	4	4	5	2	2	3
114	5	5	4	4	4	4	5	4	4	4	5	4	5	5	4	4	4	5	4	4	4
115	4	4	3	3	3	3	3	3	3	4	4	3	3	3	4	4	5	5	4	4	4
116	5	5	5	4	5	4	5	4	4	4	5	4	4	4	5	5	5	4	4	4	5
117	5	5	5	5	5	5	5	5	5	5	5	5	5	5	5	5	5	5	5	5	5
118	5	4	5	5	5	5	5	4	4	4	5	4	4	4	5	5	5	5	4	4	4
119	5	5	4	4	4	4	5	5	5	5	5	5	5	5	5	5	5	5	5	5	5
120	5	4	5	4	5	5	5	5	4	5	4	5	5	5	5	5	5	5	4	5	4
121	5	5	3	4	4	4	5	5	5	4	5	5	5	4	5	5	5	5	4	5	5
122	3	4	5	4	5	5	5	4	5	5	4	4	4	4	5	5	5	4	4	4	4
123	5	5	5	5	5	5	5	5	5	5	5	5	5	5	5	5	5	5	5	5	5
124	5	5	4	4	4	4	5	4	4	4	5	4	4	4	5	5	5	5	5	5	5
125	5	5	3	4	4	4	5	4	4	4	5	5	5	4	5	5	5	4	4	4	5
126	5	5	5	5	5	5	5	4	4	4	5	4	4	4	5	5	5	5	4	4	4
127	5	4	5	5	5	5	5	4	4	4	5	4	4	4	5	5	4	4	4	4	4
128	5	5	5	5	5	5	5	4	4	4	5	4	4	4	5	5	5	5	5	4	4
129	5	4	5	4	5	5	5	4	5	4	5	4	4	4	5	5	5	4	4	4	4
130	5	5	5	5	4	4	5	4	4	4	5	4	4	4	5	5	5	4	4	4	5
131	3	3	2	2	2	2	2	2	1	1	1	1	1	1	2	2	1	2	1	1	2
132	2	2	2	2	2	4	1	2	2	3	4	1	3	2	5	1	1	1	2	1	2
133	2	2	2	2	2	4	1	2	1	2	1	1	1	1	2	2	1	2	1	1	2
134	2	2	2	2	2	4	2	2	2	3	3	2	3	5	1	1	3	4	1	2	2
135	2	2	2	2	2	4	1	1	2	2	2	1	1	1	2	2	2	2	1	1	1
136	2	2	1	1	1	1	2	1	1	2	1	2	2	2	1	5	3	4	2	1	2
137	4	4	3	3	3	3	1	1	4	3	3	2	3	5	1	1	1	4	2	2	3
138	3	3	2	2	2	2	3	3	3	4	4	3	3	3	4	4	4	5	2	3	1
139	3	3	4	3	3	3	5	2	3	3	4	3	3	3	4	4	3	2	5	3	2
140	5	5	3	4	4	4	5	4	4	4	5	4	4	4	5	5	5	4	4	4	5
141	3	4	5	4	5	5	3	3	2	5	4	3	3	3	4	4	3	5	4	3	2
142	4	4	3	3	3	3	5	4	4	4	5	4	5	5	4	4	5	5	4	4	4
143	5	5	4	4	4	4	3	3	3	4	4	3	3	3	4	4	4	5	2	2	3
144	3	3	4	3	3	3	5	4	4	4	5	3	3	3	4	4	3	2	4	3	2
145	5	5	4	4	4	4	5	4	4	4	5	4	5	5	4	4	4	5	4	4	4
146	4	4	3	3	3	3	5	4	4	4	5	3	3	3	4	4	4	5	3	2	1
147	5	5	4	4	4	4	5	4	4	4	5	4	5	5	4	4	5	5	4	4	4
148	5	5	4	4	4	4	3	2	3	4	4	3	3	3	4	4	5	3	4	2	1
149	3	4	3	3	3	3	3	5	2	2	4	4	5	5	4	4	5	4	4	4	5
150	3	4	5	4	5	5	3	2	3	5	4	3	3	3	4	4	3	5	4	2	3
151	4	4	3	3	3	3	5	4	4	4	5	3	3	3	4	4	5	4	2	3	2
152	5	5	4	4	4	4	3	2	3	2	4	4	5	5	4	4	5	4	2	3	2
153	4	4	3	3	3	3	5	4	4	4	5	5	4	2	4	1	5	5	4	4	4
154	5	5	3	4	4	4	5	4	4	4	5	4	5	5	4	4	5	4	4	4	5
155	4	4	3	3	3	3	5	4	4	4	5	4	2	2	4	5	5	4	2	2	3
156	5	5	3	4	4	4	5	4	4	4	5	5	5	4	5	5	5	4	5	4	5
157	1	2	2	1	1	1	3	2	2	3	2	5	1	2	3	1	1	4	2	2	3
158	4	4	3	3	3	3	4	2	2	3	1	2	2	2	5	1	4	3	2	1	2
159	5	5	4	4	4	4	3	5	2	2	4	4	5	5	4	4	5	1	2	3	4
160	2	1	1	2	1	1	2	2	2	3	3	1	1	1	1	3	1	1	1	2	2
161	5	5	5	5	5	5	5	5	5	5	5	5	5	5	5	5	5	5	5	5	5
162	5	5	5	5	5	5	5	5	5	5	5	5	5	5	5	5	5	5	5	5	4
163	5	5	4	4	4	4	5	5	5	5	5	5	5	5	5	5	5	5	4	4	4
164	5	5	4	4	4	4	5	4	4	4	5	4	5	5	4	4	5	4	4	5	4
165	4	4	3	3	3	3	5	4	4	4	5	4	4	3	3	3	1	4	2	5	3
166	2	2	2	2	2	4	2	3	3	5	4	2	2	2	1	3	1	1	1	3	4
167	4	3	3	3	3	3	5	4	4	4	4	4	4	3	3	3	5	4	4	4	4
168	3	3	2	2	2	2	1	1	1	2	2	2	1	1	1	2	1	2	1	1	2
169	4	4	3	3	3	3	5	4	4	4	5	2	5	2	3	5	4	2	3	2	2
170	2	1	1	2	1	1	2	1	1	2	1	1	2	4	3	2	3	4	1	2	2

2. Kompetensi personal

No.	Kompetensi Personal																			
	X2.11	X2.12	X2.13	X2.14	X2.15	X2.21	X2.22	X2.23	X2.24	X2.25	X2.31	X2.32	X2.33	X2.34	X2.35	X2.41	X2.42	X2.43	X2.44	X2.45
1	5	4	4	4	5	3	3	4	3	4	3	3	3	3	4	4	4	5	4	5
2	5	5	4	3	5	4	4	4	4	4	4	4	4	5	4	4	4	4	5	5
3	5	4	4	4	1	4	5	4	5	4	4	4	4	4	3	4	2	5	3	3
4	3	2	3	4	4	4	3	2	5	5	4	3	3	3	4	4	4	5	4	5
5	2	2	3	5	3	5	3	2	1	2	3	4	3	3	3	5	3	3	4	4
6	4	5	4	3	2	3	2	5	3	5	5	4	4	4	5	5	2	4	3	3
7	3	3	3	4	4	3	3	3	4	4	4	4	4	5	4	5	3	5	5	4
8	5	4	4	3	2	3	4	4	3	3	3	3	3	3	3	4	4	3	4	3
9	5	4	4	4	5	4	4	4	5	4	3	4	3	3	3	4	2	5	3	1
10	2	4	3	5	4	2	5	5	5	5	5	4	5	4	4	5	5	5	5	5
11	5	5	5	5	5	4	5	5	5	4	5	5	5	5	3	5	4	5	4	5
12	1	2	3	4	5	4	4	4	3	3	3	3	3	4	5	2	4	3	3	
13	5	5	4	4	5	5	5	5	3	5	5	5	4	5	4	5	4	5	4	5
14	4	5	4	3	2	3	3	4	3	4	5	4	4	5	4	3	5	3	4	4
15	5	5	4	4	5	4	5	5	5	4	4	4	4	5	4	4	4	5	4	5
16	2	1	4	5	3	4	4	4	5	5	5	5	4	4	4	4	2	5	3	3
17	5	3	3	4	2	3	4	4	3	3	3	3	4	3	3	4	4	4	5	5
18	3	2	3	4	4	4	5	4	5	4	4	4	4	4	3	4	4	3	4	3
19	3	3	3	4	2	3	3	4	3	4	3	3	3	3	3	4	4	5	4	5
20	5	5	5	4	5	4	3	2	5	5	5	4	4	5	4	5	4	5	5	5
21	5	5	5	5	4	4	5	5	4	5	4	5	5	5	4	5	4	5	4	5
22	5	4	4	3	2	3	3	3	4	4	4	4	4	4	3	4	4	3	4	3
23	4	5	4	4	1	4	3	2	5	5	5	4	4	5	4	3	3	3	4	4
24	4	5	4	3	2	5	4	5	4	5	5	4	4	5	4	5	4	5	5	5
25	5	5	5	5	5	5	5	5	5	5	5	4	4	4	5	3	4	5	5	5
26	5	5	4	4	5	4	4	4	4	4	4	4	4	5	5	5	5	5	5	5
27	5	4	4	3	2	4	5	5	5	4	4	4	4	4	3	4	4	3	4	3
28	4	5	5	5	4	4	4	4	5	4	4	5	5	5	4	5	4	5	4	5
29	5	5	5	4	5	4	4	5	4	5	5	4	4	5	4	4	5	5	4	5
30	5	4	5	4	5	4	5	5	5	4	5	5	4	5	4	5	4	5	4	5
31	1	1	1	2	2	2	2	3	3	2	1	1	1	2	2	2	2	1	1	1
32	2	2	2	4	2	2	3	4	2	1	2	1	1	1	2	2	3	3	2	2
33	1	2	1	1	1	4	3	1	2	2	3	2	2	2	3	2	1	1	1	2
34	2	1	3	2	4	1	1	1	1	1	1	1	1	2	2	2	3	3	2	2
35	4	3	2	1	2	1	1	2	2	1	1	3	2	2	4	2	3	2	2	2
36	2	1	1	2	1	2	2	3	3	2	2	1	1	1	1	2	4	2	2	2
37	5	3	3	4	2	3	3	3	4	4	3	3	3	3	4	1	4	3	2	2
38	2	2	3	2	3	2	2	3	3	2	3	2	2	2	3	1	2	2	1	1
39	2	4	3	5	4	3	2	5	3	5	2	3	2	2	5	4	4	5	4	5
40	2	1	4	5	3	3	3	4	3	4	3	3	3	3	3	3	5	3	4	4
41	1	2	3	4	5	4	5	2	3	2	5	4	3	2	1	4	2	5	3	2
42	5	4	3	2	1	2	3	4	4	4	3	4	3	3	4	4	4	4	5	5
43	2	2	3	5	3	4	5	4	5	4	3	4	3	3	3	4	4	3	4	3
44	1	2	3	4	5	4	4	4	5	4	3	3	3	3	4	4	2	5	3	3
45	4	5	4	3	2	4	5	5	5	4	4	4	4	5	4	5	3	5	5	4
46	2	4	3	5	4	4	5	4	5	4	5	4	5	5	4	4	4	3	4	3
47	4	5	4	3	2	5	4	5	5	4	4	4	4	5	4	5	4	5	4	5
48	2	2	3	5	3	4	4	4	4	5	5	4	4	5	4	3	5	3	4	4
49	5	4	4	4	5	4	4	4	5	4	3	3	3	3	4	5	2	4	3	3
50	2	1	4	5	3	4	5	4	5	4	4	4	4	4	3	4	2	5	3	3
51	5	5	5	5	5	5	5	5	5	5	5	5	5	5	4	4	4	5	4	5
52	5	4	4	4	1	5	3	2	1	2	5	4	4	5	4	3	3	3	4	4
53	5	3	3	4	2	4	5	2	3	2	1	2	3	4	5	4	2	5	3	2
54	5	4	4	3	2	3	4	4	3	3	3	3	3	3	4	2	5	3	3	3
55	3	2	3	4	4	2	1	4	2	3	2	1	4	2	3	2	3	3	2	2
56	2	2	3	5	3	4	3	2	2	1	5	4	3	2	1	5	2	4	3	3
57	4	3	2	1	2	2	3	1	2	4	1	2	3	4	2	4	2	5	3	3
58	3	2	3	2	2	2	2	2	5	1	2	3	2	2	3	5	2	4	3	3
59	4	5	4	4	1	5	4	5	4	5	5	4	4	5	4	4	5	4	5	5
60	5	4	4	3	2	5	5	5	5	5	4	4	4	5	5	4	4	4	5	5
61	4	5	4	3	2	4	5	5	4	5	4	4	4	5	4	5	5	5	5	5
62	5	5	5	5	4	5	5	5	5	5	5	5	5	5	5	4	4	5	4	5
63	4	3	2	1	2	3	3	4	3	4	3	4	3	3	2	3	3	2	2	2
64	2	2	2	4	2	2	3	4	1	2	2	3	2	2	3	3	3	3	4	4
65	3	3	3	4	2	4	4	2	2	1	3	3	3	3	4	4	2	5	3	2
66	1	2	3	4	5	2	3	2	2	4	3	3	3	3	3	5	2	4	3	3
67	5	5	5	5	3	4	3	2	5	5	5	5	5	5	5	5	2	4	3	3
68	5	4	5	3	2	4	4	4	4	4	4	4	4	5	4	4	4	5	4	5
69	4	5	4	3	2	4	5	4	5	4	5	5	5	5	3	5	4	4	5	5
70	4	5	5	5	5	4	5	5	5	4	4	5	5	5	4	5	3	5	5	4
71	4	5	4	3	2	3	3	4	3	4	4	4	4	4	3	4	4	3	4	3
72	5	4	3	2	1	4	4	4	5	4	3	3	3	3	4	5	5	4	3	4
73	3	3	3	4	4	5	3	2	1	2	5	4	4	5	4	3	3	5	4	4
74	1	2	3	4	5	4	4	4	4	5	4	3	3	3	4	5	2	4	3	3
75	2	4	3	5	4	3	2	5	3	5	5	4	4	5	4	4	5	4	5	5
76	5	5	4	5	5	4	4	4	5	4	4	4	4	5	4	5	4	5	4	5
77	5	5	4	5	5	4	5	4	5	4	4	4	4	4	3	5	4	5	5	5
78	5	4	4	3	2	5	4	5	4	3	5	5	5	5	5	4	4	5	4	5

79	5	3	3	4	3	3	3	3	4	4	4	4	4	5	4	4	4	5	4	5		
80	5	3	3	4	2	3	4	4	4	3	3	4	3	3	4	2	5	3	3			
81	5	4	3	2	1	4	5	2	3	1	5	4	3	2	1	4	4	4	5	5		
82	5	3	3	4	3	3	2	5	3	5	2	4	4	4	5	3	3	5	4	4		
83	5	3	3	4	2	2	4	2	5	4	3	3	3	3	3	4	2	5	3	2		
84	3	2	3	2	2	2	2	3	3	2	2	2	3	2	3	1	1	1	2	2		
85	4	3	2	1	2	1	1	2	1	2	1	1	1	2	2	2	3	3	2	2		
86	2	1	3	4	2	2	3	1	2	4	1	2	2	2	1	2	3	3	2	2		
87	5	3	3	5	2	4	5	5	4	5	4	4	5	4	5	4	5	4	5	5		
88	5	4	4	4	1	4	3	2	5	5	5	5	4	4	4	4	4	5	4	5		
89	5	4	4	3	2	5	3	2	1	2	3	3	4	3	3	3	3	5	4	4		
90	1	2	3	4	5	3	4	4	3	3	4	4	4	5	4	4	4	5	4	5		
91	5	5	4	5	5	4	4	4	4	3	5	5	5	5	5	5	5	5	5	5		
92	5	4	4	3	2	5	3	3	3	2	4	5	3	2	1	4	4	4	5	5		
93	3	3	3	4	2	4	4	4	4	3	4	3	3	4	3	3	5	2	4	3	3	
94	4	5	5	5	5	3	4	4	3	4	5	4	4	4	4	5	5	5	5	5	5	
95	3	3	3	4	4	3	3	4	3	4	3	4	3	3	3	5	5	3	4	4	4	
96	5	4	3	5	2	5	4	5	5	4	5	5	5	4	4	4	5	5	4	5	5	
97	5	5	4	5	4	4	5	5	5	4	5	5	4	5	4	4	4	5	4	5	5	
98	5	5	5	4	5	4	4	4	4	4	5	5	3	5	5	3	5	3	4	4	4	
99	4	5	5	5	5	3	2	5	3	5	5	4	5	5	4	5	4	4	5	5	5	
100	4	5	4	3	2	3	3	3	4	4	4	4	4	5	4	4	2	5	3	3	3	
101	2	4	4	3	5	4	4	5	4	2	2	4	4	4	4	3	4	4	3	4	3	3
102	3	3	3	4	2	5	4	5	4	3	3	3	4	3	3	3	3	3	3	4	4	5
103	5	3	3	5	2	4	5	5	5	4	4	4	4	5	4	4	4	5	4	4	5	5
104	5	3	3	5	2	5	5	5	5	5	4	5	4	4	5	4	4	4	4	5	5	5
105	5	4	4	3	2	4	5	5	4	5	4	4	5	4	4	5	5	5	5	5	5	5
106	2	4	3	5	4	4	5	4	5	4	4	4	4	4	4	3	5	5	4	5	5	5
107	5	4	4	3	2	3	2	5	3	5	3	5	4	4	5	4	3	3	3	4	4	4
108	5	4	3	2	1	3	3	3	4	4	3	3	3	3	3	3	4	4	3	4	4	3
109	5	4	4	3	2	5	4	2	4	5	5	4	4	5	4	4	5	5	4	5	5	5
110	5	5	4	5	5	3	2	5	3	5	5	5	5	5	5	5	5	5	5	5	5	5
111	5	4	4	3	2	5	4	5	5	4	4	4	4	4	5	4	5	5	5	5	5	5
112	5	5	5	5	4	4	4	4	5	4	5	5	4	5	4	5	4	5	4	5	5	5
113	5	4	4	3	2	4	5	5	4	5	4	4	4	4	5	4	5	5	5	5	5	5
114	5	5	5	5	5	5	4	5	5	4	5	5	5	5	3	4	4	4	3	4	3	3
115	5	5	5	5	5	4	3	2	5	5	4	5	4	4	5	5	5	5	5	5	5	5
116	2	4	3	5	4	5	3	2	1	2	3	4	3	3	3	3	5	3	3	4	4	4
117	3	2	3	4	4	5	2	5	2	3	5	4	3	2	1	5	3	4	5	4	5	4
118	5	5	4	3	5	4	3	4	3	3	4	4	4	5	4	4	2	5	3	2	2	2
119	2	2	3	5	3	4	5	4	5	4	3	3	3	3	4	4	4	4	3	4	3	3
120	1	2	3	4	5	4	4	4	5	4	3	3	3	3	3	5	2	4	3	3	3	3
121	5	4	4	3	2	4	4	4	4	4	5	5	4	4	5	4	3	3	5	4	4	4
122	4	5	4	3	2	5	4	5	4	3	5	5	4	5	4	5	4	5	4	5	4	5
123	5	4	4	4	1	4	5	5	5	4	4	4	4	4	3	5	4	4	4	5	5	5
124	2	4	3	5	4	5	5	5	5	5	5	5	5	5	5	5	4	4	5	4	5	5
125	5	4	4	3	2	3	2	5	3	5	5	4	5	5	4	4	5	5	4	5	5	5
126	3	3	3	4	4	5	3	2	1	2	5	4	5	4	4	4	4	4	4	5	5	5
127	3	3	3	4	2	3	3	4	3	4	3	4	3	3	3	3	4	4	5	4	5	5
128	5	3	3	4	2	4	5	4	5	4	3	3	3	3	4	4	2	5	3	3	3	3
129	5	3	3	4	2	3	3	3	4	4	3	3	3	3	3	4	2	5	3	1	1	1
130	5	4	3	2	1	3	4	4	3	3	4	3	3	3	3	3	5	3	4	4	4	4
131	1	2	3	4	5	2	2	3	3	2	3	2	2	2	2	3	4	2	5	3	3	3
132	2	3	3	2	2	5	2	2	1	2	3	3	3	3	4	2	3	3	2	2	2	2
133	3	3	3	2	1	2	2	3	3	2	3	3	3	3	3	5	2	2	4	3	3	3
134	5	3	3	4	2	1	3	4	2	2	3	5	4	2	1	2	3	3	2	2	2	2
135	5	4	3	2	1	4	3	2	4	1	2	3	3	2	2	3	3	3	4	4	4	4
136	5	3	2	1	1	2	3	2	2	4	2	1	2	2	2	2	2	3	3	2	2	2
137	4	2	3	1	2	1	1	2	2	1	1	1	1	2	1	2	1	1	1	1	1	1
138	2	1	1	2	1	2	1	1	2	1	1	1	1	1	3	2	1	2	1	1	1	1
139	3	2	3	2	2	1	1	2	2	1	1	2	1	1	1	2	3	3	2	2	2	2
140	4	5	5	5	5	5	4	5	4	5	5	5	4	5	4	5	5	4	5	5	5	5
141	4	3	2	5	5	4	4	4	5	4	4	4	4	5	4	5	4	5	4	5	4	5
142	4	5	5	5	5	4	5	5	4	5	5	5	5	3	5	5	4	4	3	4	3	3
143	5	5	5	5	5	5	3	2	5	5	4	4	5	5	4	5	5	5	5	5	5	5
144	5	5	5	4	5	4	4	4	4	5	5	4	5	5	4	4	5	5	5	4	5	5
145	5	4	4	3	2	5	4	5	5	4	5	5	5	5	5	5	5	5	5	5	5	5
146	5	4	5	4	5	4	5	5	4	5	4	4	4	5	4	3	5	4	5	5	5	5
147	5	5	5	5	5	5	4	5	4	3	5	4	4	4	5	4	4	5	4	5	4	5
148	5	5	4	3	5	4	4	4	4	4	4	4	4	5	4	5	5	5	5	5	5	5
149	5	5	5	4	5	3	2	5	3	5	5	4	4	5	4	5	4	5	5	5	5	5
150	5	4	4	4	5	5	4	5	5	4	4	4	4	5	4	4	4	4	5	5	5	5
151	5	5	4	3	5	4	4	4	4	4	4	5	5	5	4	5	5	5	5	5	5	5
152	5	5	5	5	5	4	5	4	5	4	5	5	3	5	5	4	5	5	4	5	4	5
153	5	4	4	3	2	4	4	4	4	5	5	5	5	5	5	5	5	5	5	5	5	5
154	5	5	4	5	4	5	4	5	4	3	5	4	4	5	4	5	3	3	4	4	4	4
155	2	4	3	5	4	4	4	4	4	5	4	5	4	4	5	5	5	5	5	5	5	5
156	4	5	4	3	2	3	3	4	3	4	5	4	4	5	4	3	5	3	4	4	4	4
157	3	2	4	2	2	1	4	3	2	4	2	4	5	1	2	2	3	3	2	2	2	2
158	3	2	3	2	2	1	1	1	1	2	3	1	2	2	4	2	3	3	2	2	2	2
159	4	5	4	4	1	5	5	5	5	5	5	4	4	4	5	5	5	5	5	5	5	5
160	4	3	2	1	2	2	3	1	2	4	4	1	2	2	3	3	3	3	4	4	4	4
161	3	3	3	4	2	4	3	2	5	4	4	4	4	5	4	4	5	4	5	4	5	5

162	5	4	4	3	2	3	2	5	3	5	5	4	3	2	1	4	2	5	3	2
163	1	2	3	4	5	4	4	4	4	4	3	4	3	3	3	4	4	4	5	5
164	5	5	5	5	5	4	5	5	5	4	5	5	5	5	3	5	4	4	5	5
165	5	4	4	3	3	4	5	4	5	4	4	4	4	4	3	4	5	5	4	5
166	2	1	1	1	2	2	2	3	3	2	1	1	1	2	2	2	1	1	1	1
167	4	5	5	5	5	4	4	4	5	4	4	4	4	5	4	4	4	5	4	5
168	4	3	2	1	2	3	3	2	2	2	3	2	2	1	4	4	2	5	3	3
169	4	4	3	4	3	4	5	5	4	5	4	4	4	4	3	4	4	3	4	3
170	2	3	3	2	2	4	4	3	3	3	3	3	3	3	4	2	3	3	2	2

3. Integritas Karyawan

No.	Integritas karyawan														
	X3.11	X3.12	X3.13	X3.14	X3.15	X3.21	X3.22	X3.23	X3.24	X3.25	X3.31	X3.32	X3.33	X3.34	X3.35
1	5	5	5	5	5	5	5	4	5	5	5	5	5	5	5
2	5	5	5	5	5	4	4	4	5	5	5	5	4	4	4
3	4	5	2	5	4	5	4	3	2	2	5	3	3	3	2
4	3	3	4	4	3	5	4	4	5	4	4	4	5	4	5
5	4	3	4	2	5	4	5	4	5	4	5	5	4	4	4
6	4	3	3	3	3	4	5	3	2	2	4	3	3	3	4
7	5	4	4	2	5	5	4	4	5	4	4	5	4	5	4
8	5	5	5	5	5	5	5	5	5	5	5	5	5	5	5
9	5	5	5	5	5	5	5	4	5	5	5	5	5	5	5
10	3	3	4	4	4	3	4	5	3	2	2	4	5	4	4
11	4	4	3	3	3	2	2	3	5	4	4	4	5	4	5
12	5	5	5	5	5	5	5	5	5	5	5	5	5	5	5
13	4	5	4	5	4	5	4	4	5	3	5	3	3	3	2
14	4	5	4	5	4	5	5	5	5	5	5	5	4	4	4
15	4	3	4	5	4	3	5	5	5	4	5	5	4	4	4
16	5	5	5	5	5	5	5	5	5	5	4	5	5	4	4
17	4	4	3	3	3	2	2	3	5	4	4	5	4	5	4
18	4	3	4	5	4	2	5	3	2	4	4	4	3	3	3
19	4	5	4	2	5	4	4	4	5	5	5	5	5	5	5
20	5	4	4	5	4	2	5	3	2	4	4	4	3	3	3
21	3	3	4	4	3	4	5	3	2	2	3	3	3	3	2
22	5	4	4	5	4	5	5	5	5	5	4	4	5	4	5
23	5	5	5	5	5	5	5	5	5	5	5	5	5	5	5
24	4	4	3	3	3	5	4	3	2	2	4	4	3	3	3
25	4	4	3	3	3	5	4	4	5	4	3	3	3	3	5
26	5	4	4	5	4	4	4	4	5	5	5	5	4	4	4
27	4	5	4	5	4	2	2	3	5	4	4	5	4	5	4
28	3	3	4	4	3	4	4	5	3	2	2	5	3	3	2
29	4	4	3	3	3	5	4	4	5	3	4	4	5	4	5
30	4	4	3	3	3	4	4	5	4	4	4	4	3	3	3
31	3	3	4	4	3	2	5	3	2	4	5	3	3	3	2
32	3	3	2	2	2	3	2	2	2	3	4	2	2	2	2
33	4	4	3	3	3	2	2	3	5	4	2	2	3	3	2
34	4	4	3	3	3	4	5	3	2	2	4	2	2	2	2
35	3	3	4	4	3	3	3	2	2	2	2	2	2	3	3
36	4	2	2	2	2	3	2	2	3	2	4	2	2	2	2
37	2	1	1	1	1	2	2	2	2	2	1	1	1	2	2
38	2	2	1	1	1	2	2	1	1	1	1	2	1	2	1
39	5	5	5	5	5	5	5	5	5	5	5	5	5	5	5
40	4	3	4	5	4	5	5	5	5	5	5	5	4	4	4
41	4	5	4	5	4	5	5	5	5	5	5	5	5	5	5
42	5	5	5	5	5	3	5	5	5	4	5	5	5	5	5
43	5	5	5	5	5	5	5	5	5	5	5	5	5	5	5
44	5	5	5	5	5	5	5	4	5	5	4	3	5	5	5
45	4	4	3	3	3	5	4	3	2	2	5	3	3	3	2
46	4	3	4	5	4	4	5	4	5	4	5	5	4	4	4
47	4	4	3	3	3	2	2	3	5	4	4	4	3	3	3
48	5	4	4	5	4	4	4	4	5	5	4	5	5	5	3
49	4	4	3	3	3	5	4	3	2	2	4	3	3	3	4
50	4	3	4	5	4	5	4	4	5	4	5	5	4	4	4
51	4	4	3	3	3	4	4	4	5	5	4	4	3	3	3
52	5	4	4	5	4	4	5	4	5	3	4	5	5	4	4
53	4	5	4	5	4	5	5	5	5	5	5	5	5	5	5
54	5	5	5	5	5	5	5	5	5	5	5	5	5	5	5
55	2	2	1	1	1	3	2	2	2	3	2	3	2	2	3
56	1	2	1	1	1	2	2	3	2	2	1	1	1	2	2
57	2	1	1	2	1	1	1	1	2	2	4	2	2	2	2
58	1	2	2	1	1	3	2	2	3	2	2	2	3	3	2
59	4	4	3	3	3	2	2	3	5	4	5	5	4	4	4
60	4	5	4	5	4	4	4	4	3	5	3	3	5	3	3
61	3	3	4	4	3	4	4	5	3	2	4	5	5	4	4
62	5	4	4	5	4	5	4	4	5	4	4	4	5	4	5
63	4	2	2	2	2	2	1	1	1	2	1	1	2	1	2
64	3	3	2	2	2	3	3	2	2	2	2	2	2	3	3
65	4	2	2	2	2	2	3	2	2	3	4	2	2	2	2
66	3	3	2	2	2	2	5	3	2	4	4	4	3	3	3
67	5	5	5	5	5	5	5	5	5	5	5	5	5	5	5
68	5	4	4	5	4	5	4	3	5	4	5	5	4	4	4
69	5	5	5	5	5	5	5	5	5	5	5	5	5	5	5
70	4	5	4	5	4	4	4	4	5	5	4	4	5	4	5
71	5	5	5	5	5	4	4	4	5	5	5	5	5	5	5
72	4	3	4	5	4	5	5	4	5	5	4	4	5	4	5
73	5	5	5	5	5	3	5	3	5	4	4	5	5	4	4
74	4	5	4	5	4	4	4	4	5	5	5	5	4	4	4

No.	Integritas karyawan														
	X3.11	X3.12	X3.13	X3.14	X3.15	X3.21	X3.22	X3.23	X3.24	X3.25	X3.31	X3.32	X3.33	X3.34	X3.35
75	4	3	4	5	4	5	5	5	5	5	5	3	5	3	5
76	5	5	5	5	5	5	5	4	5	5	5	5	5	5	5
77	3	3	4	4	3	2	5	3	2	4	4	3	5	5	5
78	4	4	3	3	3	3	5	5	5	4	4	3	3	3	4
79	5	5	5	5	5	5	5	5	5	5	5	5	5	5	5
80	5	4	4	5	4	5	4	4	5	4	4	5	4	5	4
81	5	5	5	5	5	5	5	5	5	5	5	5	5	5	5
82	4	3	4	5	4	4	5	4	5	4	4	5	5	4	4
83	4	4	3	3	3	4	5	3	2	2	4	3	5	5	5
84	3	3	2	2	2	3	2	2	3	2	5	3	3	3	2
85	4	2	2	2	2	5	4	3	2	2	2	2	3	3	2
86	3	3	2	2	2	2	3	2	2	2	3	3	3	3	5
87	5	4	4	5	4	5	4	4	5	4	5	5	5	5	5
88	4	3	4	4	5	4	4	4	4	5	3	5	5	4	4
89	5	4	4	5	4	5	4	4	5	4	4	5	4	5	4
90	4	5	4	5	4	4	5	4	5	4	5	5	4	4	4
91	5	5	5	5	5	5	5	5	5	5	5	5	5	5	5
92	5	4	4	5	4	5	5	5	5	5	4	5	5	5	3
93	5	5	5	5	5	5	5	4	5	5	5	5	5	5	5
94	4	5	4	5	4	4	4	4	5	5	5	5	5	5	5
95	4	5	4	5	4	4	4	4	5	3	4	5	5	4	4
96	5	5	5	5	5	5	5	5	5	5	5	5	5	5	5
97	5	5	5	5	5	5	5	4	5	5	5	5	5	5	5
98	5	5	5	5	5	5	5	5	5	5	5	5	4	4	4
99	5	5	5	5	5	5	5	5	5	5	5	5	5	5	5
100	5	5	5	5	5	3	5	5	5	4	4	4	5	4	5
101	4	3	4	5	4	5	4	4	5	4	5	5	5	5	5
102	5	5	5	5	5	5	5	5	5	5	5	5	5	5	5
103	5	5	5	5	5	3	5	5	5	4	5	5	5	5	5
104	4	3	4	5	4	5	4	4	5	4	3	5	5	4	5
105	5	5	5	5	5	4	4	4	5	5	4	5	4	5	4
106	5	4	4	5	4	5	4	4	3	4	4	4	5	4	5
107	4	5	4	5	4	4	4	4	5	4	4	5	5	4	4
108	4	3	4	5	4	4	3	5	5	4	5	5	4	4	4
109	5	5	5	5	5	5	4	4	3	4	4	5	5	4	4
110	5	5	5	5	5	5	5	5	5	5	5	5	5	5	5
111	5	4	4	5	4	4	4	4	5	5	4	5	5	4	4
112	5	5	5	5	5	5	5	4	5	5	5	5	5	5	5
113	4	3	4	5	4	4	5	4	5	4	4	4	5	4	5
114	5	5	5	5	5	5	5	5	5	5	5	5	5	5	5
115	5	4	4	5	4	5	5	5	5	5	5	5	4	4	4
116	3	3	4	4	3	4	5	3	2	2	5	3	3	3	2
117	4	4	3	3	3	4	4	4	5	5	5	2	2	2	2
118	4	5	4	5	4	5	4	4	5	4	4	5	5	4	4
119	4	4	3	3	3	2	2	3	5	4	4	4	3	3	3
120	4	4	3	3	3	5	4	3	2	2	4	3	3	3	4
121	4	3	4	5	4	3	5	5	3	4	4	5	5	4	4
122	3	3	4	4	3	5	4	4	5	4	4	3	3	3	4
123	4	5	4	5	4	4	5	4	5	4	4	5	4	5	4
124	4	4	3	3	3	5	4	4	5	4	4	4	3	3	3
125	5	4	4	5	4	4	4	4	5	5	5	5	4	4	4
126	4	4	3	3	3	4	5	3	2	2	5	3	3	3	2
127	4	4	3	3	3	5	4	3	2	2	4	4	5	4	5
128	3	3	4	4	3	2	2	3	5	4	5	3	3	3	2
129	4	3	4	5	4	4	5	3	2	2	4	4	3	3	3
130	5	4	4	5	4	5	3	4	5	4	4	5	5	4	4
131	4	2	2	2	2	3	3	2	2	2	2	4	2	2	2
132	3	3	2	2	2	2	3	2	3	2	2	2	3	3	2
133	4	4	3	3	3	5	4	3	2	2	3	3	3	5	3
134	4	4	3	3	3	3	3	2	2	2	4	2	2	2	2
135	4	2	2	2	2	2	3	2	2	3	3	3	3	3	5
136	3	3	2	2	2	3	2	2	3	2	4	4	3	3	3
137	1	1	1	2	2	2	3	2	2	3	1	1	1	2	2
138	1	1	2	1	2	2	2	1	1	1	1	2	1	2	1
139	4	2	2	2	2	3	3	2	2	2	2	2	2	3	3
140	5	5	5	5	5	3	5	5	5	4	5	5	4	4	4
141	4	5	4	5	4	4	5	4	5	4	4	3	5	5	5
142	5	5	5	5	5	4	3	4	5	5	4	3	5	5	5
143	4	3	4	5	4	5	4	4	5	4	5	5	5	5	5
144	5	5	5	5	5	5	5	5	5	5	5	5	5	5	5
145	5	5	5	5	5	4	4	4	5	5	5	5	5	5	5
146	5	5	5	5	5	4	5	4	5	4	4	5	4	5	4
147	5	4	4	5	4	4	3	4	5	5	5	4	4	4	4
148	5	5	5	5	5	3	5	5	5	4	5	5	5	5	5
149	5	4	4	5	4	4	4	4	5	5	5	5	5	5	5
150	5	4	4	5	4	5	5	4	5	5	4	4	5	4	5
151	3	3	4	4	3	4	5	4	5	4	5	3	3	3	2
152	4	4	3	3	3	4	4	4	5	5	4	5	5	4	4
153	4	4	3	3	3	5	4	4	5	4	4	5	5	5	3
154	4	4	3	3	3	4	3	4	5	5	5	5	4	4	4
155	4	3	4	5	4	3	5	5	5	4	4	5	5	5	3
156	5	4	4	5	4	5	5	5	5	5	4	4	5	4	5
157	3	3	4	4	3	2	5	3	2	4	5	3	3	3	2
158	1	1	1	2	2	2	3	2	2	2	1	2	1	1	2
159	5	4	4	5	4	5	3	4	5	4	5	5	5	5	5
160	3	3	2	2	2	2	2	3	5	4	2	2	3	3	2
161	4	5	4	5	4	5	5	5	5	5	4	5	5	4	4
162	5	5	5	5	5	4	5	4	5	4	5	5	4	4	4
163	4	3	4	5	4	5	5	5	5	5	5	5	5	5	5

No.	Integritas karyawan															
	X3.11	X3.12	X3.13	X3.14	X3.15	X3.21	X3.22	X3.23	X3.24	X3.25	X3.31	X3.32	X3.33	X3.34	X3.35	
164	5	5	5	5	5	5	4	4	5	4	5	5	5	5	5	
165	4	3	4	5	4	4	4	4	5	5	5	5	5	5	5	
166	4	2	2	2	2	1	1	1	2	2	1	1	1	2	2	
167	5	5	5	5	5	4	4	4	5	5	5	5	5	5	5	
168	4	2	2	2	2	2	2	2	3	2	2	2	2	2	2	
169	4	5	4	5	4	5	5	5	5	5	5	5	5	5	5	
170	3	3	2	2	2	2	2	3	5	4	4	4	3	3	3	

4. Komitmen Organisasi

N o.	Komitmen Organisasi																									
	Z1.11	Z1.12	Z1.13	Z1.14	Z1.15	Z1.21	Z1.22	Z1.23	Z1.24	Z1.25	Z1.31	Z1.32	Z1.33	Z1.34	Z1.35	Z1.41	Z1.42	Z1.43	Z1.44	Z1.45	Z1.51	Z1.52	Z1.53	Z1.54	Z1.55	
1	5	3	4	2	3	4	3	3	3	4	3	3	3	5	3	4	4	4	4	4	4	4	4	4	4	4
2	4	5	4	5	4	5	5	2	5	5	5	3	4	2	3	5	4	4	4	5	5	3	2	4	3	3
3	5	4	5	4	4	3	3	3	4	4	4	3	4	3	4	4	4	4	5	5	4	5	4	4	4	5
4	5	4	2	3	3	3	3	3	4	4	5	3	4	2	3	3	3	3	3	5	3	3	3	4	3	3
5	3	4	3	4	3	5	3	3	3	3	4	4	3	3	3	4	3	3	5	5	3	2	4	3	3	
6	4	5	4	4	4	4	4	4	5	5	5	3	4	3	3	4	4	4	5	5	4	4	4	5	5	
7	5	3	3	2	4	4	3	3	3	4	4	3	5	3	3	4	4	3	3	3	4	3	3	3	3	3
8	4	5	4	5	4	5	5	5	4	3	5	3	5	2	3	4	3	3	3	5	4	5	4	4	5	5
9	5	5	5	4	4	5	5	5	5	4	4	5	4	5	5	4	5	5	5	4	4	4	5	5	5	5
10	5	4	5	4	4	2	4	2	5	4	5	4	4	5	5	5	4	4	4	5	4	5	4	4	5	5
11	5	3	4	2	3	3	4	3	4	3	3	4	4	5	3	3	4	3	3	5	4	4	3	3	3	3
12	3	5	4	2	3	3	3	3	3	5	4	3	4	3	3	3	3	3	3	5	5	3	2	4	3	3
13	5	3	3	3	3	4	3	3	3	4	4	5	3	3	3	4	3	3	3	4	3	3	3	3	3	5
14	5	5	4	5	3	5	4	5	4	4	5	3	4	5	3	3	5	3	3	4	4	4	4	5	5	5
15	4	5	4	5	4	5	2	4	4	4	5	5	4	2	3	3	3	3	5	3	4	5	4	4	5	5
16	5	5	4	4	4	5	5	3	5	4	4	3	3	3	3	5	5	4	4	4	5	3	2	4	3	3
17	4	3	3	2	5	4	3	3	3	4	4	5	3	3	4	5	4	4	4	5	4	4	4	5	5	5
18	4	5	4	5	4	3	4	4	4	3	5	3	4	2	3	4	4	4	5	5	4	4	4	5	5	5
19	5	4	5	4	4	5	5	5	4	4	5	5	4	5	4	4	4	4	4	4	4	5	5	5	4	4
20	5	5	4	5	3	5	4	5	4	4	4	3	4	5	3	4	4	3	3	3	4	5	4	4	4	5
21	3	4	3	4	3	3	4	3	3	4	3	3	5	3	3	4	3	3	3	5	4	4	4	4	4	4
22	5	4	5	4	4	5	3	4	5	5	5	3	4	2	3	4	4	4	5	5	4	5	4	4	5	5
23	5	5	4	5	3	5	4	5	4	4	3	4	4	5	3	4	4	4	5	5	4	5	4	4	4	5
24	3	2	4	5	3	5	4	5	4	4	4	4	5	3	3	4	3	4	3	3	4	4	4	4	5	5
25	4	5	4	5	4	5	3	5	4	5	4	3	4	3	3	4	5	3	3	4	4	4	4	5	5	5
26	4	5	4	4	4	4	3	3	3	4	5	3	4	5	3	3	3	3	3	5	4	3	3	3	3	3
27	5	5	5	5	5	3	4	4	4	5	3	3	3	5	5	3	4	4	3	4	5	5	5	5	5	5
28	5	5	5	4	4	5	5	4	5	4	5	3	3	5	5	5	4	5	5	4	5	5	5	4	4	4
29	5	5	4	5	3	5	4	5	4	4	4	5	4	5	5	5	4	5	4	4	4	4	4	4	5	5
30	5	4	5	5	4	5	5	5	4	4	5	4	4	5	5	4	5	4	5	5	5	4	5	4	5	5
31	3	1	1	1	1	2	1	1	1	2	2	2	2	2	4	2	2	1	1	1	2	2	3	2	3	3
32	2	3	2	1	4	2	2	2	2	2	3	2	1	1	2	1	2	2	1	1	2	2	1	1	1	1
33	1	2	2	1	1	1	1	1	1	3	3	3	2	2	2	1	1	1	2	1	2	3	2	4	1	1
34	2	3	2	3	2	1	1	1	1	4	1	1	2	2	1	2	2	1	2	2	1	2	1	1	2	2
35	1	1	2	1	2	1	1	1	1	3	2	3	3	2	2	1	1	1	1	2	2	2	3	2	3	3
36	1	2	2	1	1	1	1	1	2	2	2	1	1	2	1	1	1	2	2	2	1	2	1	1	1	1
37	3	5	4	2	3	3	4	3	3	4	3	3	3	4	2	2	3	3	3	2	3	2	3	2	2	3
38	4	3	3	2	5	1	3	1	2	2	2	2	3	3	2	2	1	3	1	3	2	2	3	2	3	3
39	5	4	2	3	3	3	3	3	3	4	3	3	5	3	3	3	2	3	3	3	5	3	2	4	3	3
40	3	4	3	4	3	4	3	3	3	4	3	4	4	3	3	3	4	3	3	4	3	4	3	3	3	4
41	4	5	4	5	4	5	4	3	4	4	5	3	4	5	3	4	3	3	4	4	4	4	4	4	5	5
42	3	5	4	2	3	4	3	3	3	4	4	4	5	3	3	2	2	4	4	5	4	3	3	3	3	3
43	5	3	3	2	4	4	4	4	5	5	4	3	4	3	3	3	4	3	3	4	4	4	5	4	5	4
44	5	4	5	4	4	5	3	4	4	4	3	5	3	5	3	4	3	4	4	4	4	4	4	4	4	4
45	4	5	4	5	4	5	5	5	5	4	4	5	5	5	5	5	5	5	4	4	4	5	5	5	5	5
46	4	4	5	4	5	5	4	3	4	4	5	3	4	5	3	5	5	4	4	4	4	4	4	5	5	5
47	4	4	4	3	2	4	3	3	3	4	3	3	5	3	3	4	4	2	2	4	4	3	3	3	3	4
48	5	3	3	3	3	5	4	5	4	4	5	3	3	4	5	3	5	4	4	4	5	4	4	4	5	5
49	5	4	5	4	4	5	3	4	4	4	4	4	4	3	5	4	4	4	4	4	4	5	5	5	5	5
50	4	4	5	4	5	3	4	4	4	4	5	4	4	5	5	4	4	4	5	5	5	5	5	5	5	5
51	5	5	5	5	5	5	5	5	5	5	4	4	5	5	5	4	5	4	5	5	5	5	5	5	5	5
52	5	5	4	5	3	5	4	5	4	5	3	4	4	5	3	4	4	4	5	5	5	5	5	5	5	5
53	5	4	5	4	4	5	5	5	5	4	5	3	3	4	4	4	4	4	5	5	4	5	4	4	5	5
54	4	5	5	5	5	5	5	2	5	5	4	4	3	3	5	5	4	4	4	5	4	5	5	5	5	5
55	2	1	1	1	2	1	1	1	1	3	1	2	1	2	1	1	1	1	2	2	1	1	1	1	1	2
56	2	3	2	3	2	2	2	2	2	4	2	2	3	3	2	2	2	2	1	1	2	3	2	3	2	2
57	1	2	1	2	1	1	1	1	2	2	2	1	2	1	1	1	1	1	1	2	2	2	3	2	3	3
58	3	2	3	1	3	2	2	2	2	4	2	2	2	2	4	1	2	1	2	1	1	1	1	1	1	3
59	5	5	4	5	3	5	4	5	4	4	4	4	3	5	3	3	4	4	3	4	4	4	4	4	5	5
60	4	5	4	4	4	2	2	4	5	4	4	3	4	3	3	4	4	4	5	5	4	4	4	4	5	5
61	5	4	2	3	3	3	4	3	3	4	5	3	4	2	3	5	2	2	4	2	4	5	4	5	4	4
62	3	5	4	2	3	5	3	3	3	3	4	4	5	3	3	4	4	3	4	4	4	4	4	5	5	5
63	2	2	4	2	2	1	1	1	2	2	2	1	1	1	1	1	1	2	2	2	1	1	1	1	1	2
64	3	2	4	5	3	2	2	2	4	2	2	2	3	3	2	3	2	3	2	2	4	1	2	2	3	3
65	3	4	3	4	3	3	3	2	2	2	3	3	2	2	2	3	3	2	2	2	4	3	3	3	3	4
66	5	3	3	2	4	2	2	2	2	4	2	2	3	3	2	3	3	3	2	2	2	2	3	2	3	3

N o.	Komitmen Organisasi																									
	Z1. 11	Z1. 12	Z1. 13	Z1. 14	Z1. 15	Z1. 21	Z1. 22	Z1. 23	Z1. 24	Z1. 25	Z1. 31	Z1. 32	Z1. 33	Z1. 34	Z1. 35	Z1. 41	Z1. 42	Z1. 43	Z1. 44	Z1. 45	Z1. 51	Z1. 52	Z1. 53	Z1. 54	Z1. 55	
77	4	3	3	2	5	3	4	3	4	3	4	3	3	3	4	4	3	3	3	3	3	4	5	4	4	5
78	5	4	5	4	4	3	3	3	3	3	5	3	4	2	3	4	4	3	3	3	3	5	5	4	4	4
79	4	5	4	5	4	5	5	5	5	5	5	4	5	4	5	5	5	4	5	5	5	4	5	5	5	5
80	5	5	5	5	5	5	5	5	5	5	5	5	4	2	3	5	5	4	4	4	4	4	4	4	5	5
81	5	5	5	5	5	5	5	5	5	5	4	4	5	5	5	4	4	5	5	5	5	5	5	5	5	5
82	5	5	4	5	3	5	4	5	4	4	4	3	4	3	5	5	4	4	4	4	5	4	4	4	5	5
83	5	3	3	3	3	3	4	3	3	4	5	5	3	4	2	4	4	4	4	2	2	3	3	3	3	5
84	5	4	3	2	3	5	3	3	3	3	2	2	3	3	2	3	2	2	3	2	3	2	2	2	2	3
85	3	3	1	2	3	2	2	2	2	4	2	2	2	2	4	2	3	3	3	3	3	2	2	3	2	3
86	4	3	3	2	5	3	3	3	3	3	3	4	4	3	3	4	3	3	3	3	4	5	3	2	4	3
87	5	4	5	4	4	5	3	4	4	4	4	3	5	3	5	3	5	4	4	4	4	5	5	5	4	4
88	5	4	5	4	4	3	4	4	4	4	5	5	3	4	2	3	4	4	4	3	3	5	5	5	5	5
89	3	4	3	4	3	4	3	3	3	3	4	4	3	4	3	3	4	4	4	3	4	4	5	4	4	5
90	4	5	5	5	5	5	5	2	5	5	5	5	3	4	5	3	5	4	4	5	4	4	5	5	5	5
91	4	5	5	5	5	5	5	5	5	5	4	4	5	5	5	5	5	5	5	5	5	4	5	5	5	5
92	5	5	4	4	4	5	4	4	4	5	4	5	4	5	4	3	3	4	4	4	4	4	5	4	4	5
93	5	4	5	4	4	5	3	4	4	4	4	5	3	3	3	5	4	4	3	4	3	4	4	4	4	4
94	5	3	4	2	3	3	4	3	4	3	4	4	3	3	3	4	3	3	3	3	3	3	3	3	3	5
95	5	4	5	5	4	5	3	4	4	4	4	5	4	4	2	4	4	4	4	4	4	4	4	5	5	5
96	5	4	5	4	4	5	4	3	4	4	5	3	5	2	3	3	4	4	3	4	3	4	4	5	4	5
97	5	4	5	4	4	4	3	3	3	4	4	4	3	3	5	4	4	3	3	3	3	4	4	4	4	4
98	5	5	4	5	3	5	4	5	4	4	4	3	4	5	3	5	4	4	4	5	4	5	4	5	4	5
99	5	5	4	5	4	5	4	5	4	5	4	5	3	5	5	5	4	5	4	5	5	5	5	5	5	5
100	4	5	4	5	4	5	5	5	5	5	4	4	5	5	5	4	5	4	5	5	4	5	5	5	5	5
101	4	5	4	4	4	5	5	5	5	5	4	3	5	3	4	5	4	4	4	4	5	4	5	4	4	5
102	5	5	4	5	5	5	4	5	5	4	4	5	5	5	5	5	5	4	5	4	5	5	5	5	5	5
103	3	5	4	2	3	4	3	3	3	4	3	4	5	3	3	4	3	3	5	2	3	3	3	3	3	5
104	4	4	5	4	5	5	5	5	5	5	4	4	5	3	3	5	5	4	4	5	5	5	5	5	5	5
105	5	5	5	5	5	5	5	5	5	5	4	4	3	3	5	5	5	4	4	5	5	5	5	5	5	5
106	5	5	5	5	5	3	4	4	4	4	5	5	3	4	5	3	5	5	5	5	5	4	4	4	5	5
107	5	3	3	3	3	5	3	3	3	3	4	3	4	5	3	3	3	4	3	4	3	4	5	3	3	3
108	5	4	2	3	3	3	3	3	3	3	4	3	3	3	5	3	3	3	3	4	4	5	3	2	4	3
109	3	2	4	5	3	3	4	3	3	4	4	3	4	5	3	3	4	3	3	4	5	3	3	3	3	3
110	5	4	4	4	5	4	4	4	5	5	5	3	4	2	5	3	3	4	4	4	4	4	4	4	5	5
111	4	3	3	2	5	4	3	3	3	4	3	3	3	3	3	5	5	4	4	4	4	5	3	3	3	5
112	5	4	5	4	4	5	3	4	4	4	3	3	5	4	5	4	4	4	4	4	4	4	4	4	4	4
113	3	5	4	2	3	5	5	2	5	5	3	4	4	3	3	4	4	4	4	5	5	5	3	3	3	3
114	5	4	5	4	5	4	5	4	3	4	4	4	3	4	3	5	4	4	4	4	5	5	4	5	4	5
115	5	4	2	3	3	3	4	4	4	4	5	4	4	3	3	3	3	4	3	3	3	4	5	4	4	5
116	5	5	4	5	3	4	3	3	3	4	5	3	4	2	3	4	3	3	4	3	4	5	4	4	4	5
117	4	5	4	5	4	5	3	3	3	3	4	4	3	3	3	3	4	3	3	4	5	3	2	4	3	
118	5	3	4	2	3	5	5	2	5	5	4	3	4	5	3	3	4	4	3	4	4	4	4	5	4	5
119	4	3	3	2	5	3	3	3	3	3	4	3	3	3	4	4	4	3	3	3	3	3	3	3	3	5
120	5	4	5	4	4	5	3	4	4	4	4	3	5	3	3	3	3	4	4	4	4	4	4	4	4	4
121	3	4	3	4	3	4	3	3	3	4	5	3	4	2	3	4	3	3	3	3	3	5	3	3	3	3
122	5	3	3	3	3	5	3	4	4	4	4	4	3	5	3	3	3	3	4	4	4	4	4	4	4	4
123	3	5	4	2	3	4	2	4	2	4	4	3	4	3	3	3	4	3	3	4	5	3	2	4	4	3
124	4	5	4	4	4	5	4	4	5	4	4	3	4	5	3	4	3	3	4	4	5	5	5	5	5	5
125	5	5	4	5	5	5	4	5	5	4	4	3	4	5	3	4	4	4	5	5	4	5	4	4	4	5
126	4	4	5	4	5	4	4	4	5	5	5	5	4	5	4	5	5	4	4	4	4	5	4	4	4	5
127	4	5	4	5	4	5	5	2	5	5	4	4	5	3	3	4	4	4	5	5	4	5	4	4	4	5
128	5	4	5	4	4	3	4	4	4	5	5	4	5	4	5	4	4	4	5	5	4	5	4	4	4	5
129	5	4	5	4	4	5	3	4	4	4	3	5	3	5	3	4	4	4	4	4	4	3	3	3	3	5
130	5	5	4	5	3	4	3	3	3	4	4	3	4	3	3	4	4	4	5	5	3	3	3	3	3	5
131	3	2	4	5	3	3	4	3	3	4	4	2	2	2	2	3	3	3	3	4	4	3	3	3	3	4
132	5	3	4	2	3	5	3	3	3	3	5	3	4	2	3	3	4	3	3	4	5	3	3	3	3	3
133	5	3	4	2	3	3	4	3	4	3	2	3	3	2	2	2	2	3	2	3	5	3	2	4	3	3
134	2	3	2	3	2	2	2	2	2	4	2	2	2	2	2	4	3	2	3	2	2	2	2	2	2	3
135	2	2	2	2	4	4	3	3	3	4	3	3	3	3	5	2	3	3	3	3	3	2	2	3	2	3
136	5	4	2	3	3	2	2	2	2	4	2	2	3	3	2	3	4	3	3	4	4	1	2	2	3	3
137	1	2	1	1	2	1	1	2	2	1	1	2	2	1	1	1	1	1	3	1	2	2	3	2	3	3
138	3	5	4	2	3	3	3	3	3	3	4	3	4	3	3	3	3	2	3	2	3	3	3	3	3	5
139	2	2	4	2	2	4	3	3	3	4	4	2	2	2	2	2	3	2	2	2	2	2	2	2	3	3
140	3	4	3	4	3	5	4	5	4	4	5	3	4	2	3	3	3	3	2	2	2	4	4	4	5	5
141	5	3	3	3	3	4	3	3	3	4	4	4	3	3	3	4	4	3	4	3	4	3	3	3	3	4
142	5	5	4	4	4	4	4	4	4	5	5	3	4	4	3	5	5	5	4	4	4	4	4	4	5	5
143	5	4	5	4	4	4	4	2	2	4	5	3	4	2	3	4	4	4	5	5	5	3	2	4	3	3
144	5	5	4	5	3	4	3	3	3	4	5	3	4	2	3	3	3	3	3	5	5	3	3	3	3	3

No.	Komitmen Organisasi																										
	Z1.11	Z1.12	Z1.13	Z1.14	Z1.15	Z1.21	Z1.22	Z1.23	Z1.24	Z1.25	Z1.31	Z1.32	Z1.33	Z1.34	Z1.35	Z1.41	Z1.42	Z1.43	Z1.44	Z1.45	Z1.51	Z1.52	Z1.53	Z1.54	Z1.55		
14	5	5	3	4	2	3	5	3	3	3	4	3	4	3	3	3	4	4	4	3	4	5	3	2	4	3	
14	6	4	5	4	4	4	3	4	3	3	4	4	3	3	3	4	4	4	2	3	3	4	4	4	5	5	
14	7	5	5	5	5	5	5	5	5	5	5	4	4	5	5	5	5	4	5	5	4	4	4	4	5	5	
14	8	4	5	4	5	4	5	5	2	5	5	5	5	4	2	3	5	5	5	5	5	4	4	4	5	5	
14	9	5	5	4	5	5	5	4	5	5	4	4	5	5	4	5	5	4	5	5	5	4	4	4	5	5	
15	0	5	4	5	4	4	5	3	4	4	4	5	3	4	5	2	4	4	5	4	4	4	4	4	4	4	
15	1	4	4	5	4	5	5	5	4	5	5	3	4	4	5	3	4	4	4	5	5	4	5	4	4	5	
15	2	5	5	5	5	5	5	5	5	5	5	4	4	5	3	3	4	4	5	5	5	4	5	4	4	5	
15	3	4	5	4	4	4	5	5	5	5	5	5	3	4	2	3	4	4	4	5	4	4	5	4	4	5	
15	4	5	5	4	5	5	5	4	5	4	4	5	4	4	5	5	5	5	4	5	4	5	5	5	5	5	
15	5	5	4	5	4	4	5	5	5	5	5	4	5	4	3	3	4	4	5	4	5	4	5	4	4	5	
15	6	5	5	4	5	3	5	4	5	5	4	5	5	4	2	3	4	4	4	5	5	5	5	5	5	5	
15	7	5	4	2	3	3	2	2	2	2	4	2	2	2	3	3	2	3	2	2	2	2	2	3	2	3	
15	8	2	3	2	3	2	2	2	2	4	2	3	3	2	2	2	2	2	2	3	3	3	5	3	3	3	
15	9	4	5	4	5	4	5	4	3	4	4	4	4	3	5	3	3	4	4	3	4	4	4	4	5	5	
16	0	2	3	4	1	2	4	3	3	3	4	5	3	4	2	3	4	4	3	3	2	5	2	3	2	3	
16	1	5	5	5	5	5	5	5	5	5	4	3	4	3	5	4	4	4	4	5	5	4	5	4	4	5	
16	2	4	4	4	5	4	5	5	5	5	5	4	4	3	5	3	4	4	5	5	5	5	5	5	5	5	
16	3	4	5	5	5	5	5	5	2	5	5	3	4	4	5	3	5	4	5	4	4	4	4	5	4	4	5
16	4	5	4	2	3	3	3	3	3	3	3	5	3	4	2	3	4	4	4	5	5	3	3	3	3	5	
16	5	4	3	3	2	5	4	4	2	2	4	3	5	4	3	3	2	2	3	3	3	5	3	2	4	3	
16	6	3	4	3	4	3	2	2	2	3	3	3	2	2	2	2	2	2	2	3	3	3	3	2	2	2	
16	7	4	4	4	3	2	4	3	3	3	4	2	4	3	3	3	4	4	4	4	4	4	3	3	3	5	
16	8	4	3	3	2	5	4	3	3	3	4	4	4	3	3	3	2	2	2	2	2	3	2	2	4	1	
16	9	3	5	4	2	3	3	3	3	3	3	3	3	3	3	5	4	4	3	4	4	5	3	2	4	3	
17	0	3	2	2	2	3	2	3	2	2	2	2	2	2	3	3	3	2	3	2	2	2	2	3	2	3	

5. Kinerja karyawan

No.	Kinerja karyawan														
	Y1.11	Y1.12	Y1.13	Y1.14	Y1.15	Y1.21	Y1.22	Y1.23	Y1.24	Y1.25	Y1.31	Y1.32	Y1.33	Y1.34	Y1.35
1	4	4	4	4	5	4	4	3	3	3	3	3	3	3	3
2	4	4	4	4	5	5	3	3	3	3	3	3	3	3	3
3	4	4	4	4	5	5	4	4	4	4	4	4	4	4	4
4	3	5	2	3	4	3	3	3	3	3	3	3	3	3	3
5	5	5	5	4	4	4	4	3	3	3	3	3	3	3	3
6	4	4	5	5	4	4	4	5	4	5	4	4	4	4	4
7	4	4	4	4	5	5	4	5	4	5	4	4	3	3	4
8	4	4	4	3	3	3	3	3	3	3	3	3	3	3	3
9	4	4	4	3	3	3	4	3	5	1	2	3	5	4	3
10	3	5	2	3	4	3	3	3	3	5	4	4	3	3	4
11	4	4	4	4	4	4	4	5	4	5	4	4	4	4	4
12	4	3	3	3	3	3	5	3	3	3	3	2	5	2	5
13	4	4	4	5	4	4	4	3	4	3	3	3	4	3	4
14	5	5	4	4	4	4	4	5	4	5	4	5	4	3	4
15	4	4	4	4	5	5	4	5	4	4	4	4	4	3	4
16	4	4	4	4	5	5	5	5	4	4	4	3	4	4	4
17	4	4	4	4	5	5	3	3	3	5	2	3	3	3	4
18	4	4	4	4	5	3	4	3	3	3	3	4	3	3	4
19	4	4	4	5	4	4	4	3	4	3	3	3	3	3	4
20	5	5	4	4	4	4	5	4	4	4	4	5	4	3	4
21	4	4	4	5	4	4	4	5	3	2	5	4	4	4	4
22	3	5	2	3	4	4	5	4	5	4	5	2	3	3	4
23	5	3	3	3	3	3	4	5	4	4	5	4	3	4	4
24	3	5	2	3	4	4	5	4	4	4	4	3	3	4	4
25	5	4	4	5	4	4	5	4	5	4	3	4	4	4	4
26	5	3	3	3	3	3	4	3	3	4	4	3	3	3	4
27	4	5	5	4	4	3	3	3	3	3	3	2	5	2	5
28	4	4	3	3	3	3	4	4	3	3	2	3	5	4	3
29	4	4	3	3	3	3	4	3	5	5	4	3	3	4	4
30	3	3	4	4	3	4	3	3	3	4	3	3	3	4	4
31	3	5	2	3	4	2	3	4	5	2	3	3	3	3	4
32	4	2	2	2	2	2	2	2	3	3	3	4	3	2	5
33	4	4	3	3	3	3	3	3	3	5	2	3	5	3	4
34	1	5	2	2	2	2	2	2	2	2	2	2	3	2	2
35	3	3	3	4	4	4	3	3	4	4	4	2	5	3	2
36	4	2	2	2	2	2	2	2	3	3	2	2	2	2	3
37	2	1	2	1	1	1	1	1	2	2	1	2	1	2	1
38	1	2	2	1	1	1	2	2	3	3	1	1	2	1	2
39	4	5	5	5	5	5	5	5	5	5	4	4	3	4	4
40	5	5	4	4	4	4	5	4	4	5	4	4	3	4	4
41	4	5	5	5	5	5	5	5	5	5	5	5	5	5	5
42	4	4	4	5	5	5	5	4	5	4	3	4	4	4	4
43	4	4	4	5	5	5	5	5	5	5	5	5	5	5	5
44	4	4	4	5	4	4	4	5	4	4	3	4	4	4	4
45	4	4	4	4	5	5	5	5	4	4	5	5	5	5	5
46	4	4	4	5	5	5	4	5	5	5	5	5	5	5	5
47	5	5	5	4	4	4	4	5	3	2	5	4	4	4	4
48	5	5	5	4	4	5	5	5	5	5	5	4	3	4	4
49	4	4	4	3	3	4	4	4	3	3	2	3	1	2	1
50	4	4	4	4	5	5	5	4	4	4	4	4	3	4	4
51	3	4	3	4	3	5	5	4	4	4	5	2	3	2	5
52	5	5	4	4	4	4	4	5	4	5	4	4	4	5	5
53	4	5	5	5	5	5	5	5	5	5	5	5	5	5	5
54	4	4	4	4	5	5	5	4	3	5	3	3	3	5	4
55	2	2	1	1	1	2	2	1	1	1	1	1	2	1	2
56	3	1	2	2	2	2	2	2	3	2	3	2	3	2	2
57	3	1	1	1	1	1	2	2	3	2	3	1	2	2	1
58	1	5	2	2	2	2	2	3	2	3	2	2	2	2	2
59	5	5	4	4	4	4	4	5	5	5	4	4	3	4	4

No.	Kinerja karyawan														
	Y1.11	Y1.12	Y1.13	Y1.14	Y1.15	Y1.21	Y1.22	Y1.23	Y1.24	Y1.25	Y1.31	Y1.32	Y1.33	Y1.34	Y1.35
60	4	4	4	5	5	5	5	4	4	5	5	5	5	5	5
61	5	5	5	5	5	5	5	5	4	5	4	4	3	4	4
62	4	4	4	4	5	5	4	5	3	2	5	3	4	3	4
63	2	2	4	2	2	3	2	2	2	2	1	1	2	1	2
64	4	2	2	2	2	2	2	2	2	3	3	3	4	4	3
65	2	2	4	2	2	2	2	2	2	3	3	2	2	2	2
66	3	3	3	4	4	3	3	3	4	4	5	2	3	3	4
67	4	4	4	5	5	4	5	4	4	5	3	4	4	4	4
68	5	5	5	5	5	5	5	5	5	5	4	4	3	4	4
69	4	4	5	5	5	5	5	5	5	5	5	5	5	5	5
70	4	5	5	4	5	4	5	4	5	5	4	5	5	5	5
71	4	4	5	5	5	5	5	5	5	5	5	5	5	5	5
72	4	4	5	4	4	4	5	4	4	5	4	4	4	4	4
73	4	5	4	5	5	5	5	5	5	5	5	4	5	5	4
74	4	4	5	4	4	4	5	4	4	5	5	4	4	5	5
75	5	5	4	4	4	4	4	4	4	5	5	4	4	5	5
76	4	4	5	4	4	4	5	4	4	5	4	4	4	4	4
77	3	3	3	4	4	5	4	4	5	4	4	3	3	3	4
78	4	4	4	5	5	4	5	4	5	4	3	3	3	5	4
79	5	5	5	5	5	5	5	5	5	5	5	5	5	5	5
80	4	4	5	5	4	5	5	4	4	4	4	4	3	4	4
81	4	5	5	5	5	5	5	5	5	5	5	5	5	5	5
82	5	5	5	4	4	4	5	4	5	4	5	4	3	4	4
83	5	3	3	3	3	4	5	3	2	5	3	3	3	4	4
84	3	3	3	4	4	4	4	3	2	4	3	2	5	3	4
85	3	3	3	4	4	2	2	3	2	3	2	3	3	2	2
86	3	4	3	4	3	4	4	3	2	4	4	3	3	2	5
87	4	4	5	4	4	4	4	4	4	5	4	4	4	4	4
88	4	5	5	4	4	4	5	3	2	5	4	3	3	2	5
89	5	5	4	4	4	4	5	3	2	5	5	4	3	4	4
90	5	5	5	5	5	4	5	3	2	5	5	5	5	5	5
91	5	5	5	5	5	5	5	5	5	5	5	5	5	5	5
92	5	4	5	4	4	4	5	3	2	5	4	4	3	4	4
93	4	4	3	3	3	4	4	3	3	3	3	3	5	4	4
94	4	4	4	5	5	5	4	4	4	5	4	5	3	4	4
95	4	4	5	5	5	4	5	4	4	5	4	4	4	4	4
96	4	4	5	5	5	5	5	4	4	4	3	4	3	4	4
97	5	5	5	4	4	4	5	4	5	5	5	5	5	5	5
98	5	5	4	4	4	4	4	5	4	5	4	4	4	5	5
99	5	3	3	3	3	4	2	2	2	5	3	3	3	4	4
100	5	5	5	5	5	4	5	3	2	5	3	3	4	4	4
101	4	4	5	5	5	4	5	4	5	4	4	4	3	4	4
102	5	5	4	4	4	5	5	5	4	2	5	4	3	4	4
103	4	4	4	5	5	5	4	4	4	5	5	5	5	5	5
104	4	5	5	5	5	5	5	5	5	5	5	5	5	5	5
105	4	5	5	4	4	5	5	5	5	5	5	5	5	5	5
106	4	4	4	5	5	5	4	4	4	5	4	4	3	4	4
107	5	4	4	4	4	4	5	3	2	5	4	4	3	4	4
108	4	4	5	4	4	5	4	3	3	4	3	2	5	3	4
109	5	5	4	4	4	4	4	4	4	5	4	3	3	4	4
110	4	4	4	5	5	4	5	4	4	5	4	4	3	4	4
111	4	4	4	5	5	3	3	3	3	5	4	3	3	2	5
112	4	5	5	4	4	4	5	4	4	5	4	4	4	4	4
113	4	4	4	5	5	5	5	5	5	5	3	4	3	4	4
114	4	4	5	5	5	5	5	5	5	5	5	5	5	5	5
115	4	5	5	5	4	5	4	4	4	5	4	4	3	4	4
116	4	4	3	3	3	4	5	4	5	3	3	4	4	4	3
117	3	3	5	2	2	3	2	3	4	5	4	3	3	3	4
118	4	4	4	5	5	4	5	4	5	4	3	5	3	4	4
119	3	4	3	4	3	4	3	3	3	4	5	2	3	2	5
120	4	4	3	3	3	4	5	4	4	5	4	4	4	4	4
121	3	5	2	3	4	4	4	3	3	3	3	3	3	4	4
122	5	4	5	4	5	4	5	4	5	4	4	4	4	4	4
123	4	4	5	5	5	5	5	5	5	5	5	5	5	5	5
124	4	4	4	5	5	4	5	3	2	5	4	4	3	4	4
125	5	5	5	4	4	5	5	5	5	4	5	4	5	5	5
126	4	5	5	5	5	5	5	5	5	5	3	4	3	4	4
127	4	4	5	4	5	5	5	5	5	5	5	5	5	5	5
128	4	4	4	5	4	3	3	3	3	5	4	3	3	3	4
129	5	3	3	3	3	2	3	3	4	5	2	3	5	3	4
130	4	4	3	3	3	3	3	3	3	4	3	3	3	4	4
131	4	2	2	2	2	2	2	2	3	3	3	2	2	3	3
132	3	3	3	4	4	4	3	3	3	5	3	3	3	2	4
133	4	2	2	2	2	2	2	2	2	2	2	2	2	2	2
134	1	5	2	2	2	2	2	2	3	3	5	2	3	3	4
135	4	4	3	3	3	2	2	2	3	3	5	2	2	2	1
136	3	3	3	4	4	4	4	3	3	3	2	2	3	2	2
137	2	1	2	1	1	2	2	2	3	3	2	3	3	2	2
138	1	1	1	1	3	1	2	1	1	2	1	1	1	2	2
139	1	1	2	2	2	3	1	1	1	2	2	2	2	2	4
140	5	5	4	4	4	4	4	5	3	2	5	4	3	4	4
141	4	4	3	3	3	3	2	3	4	5	3	2	5	3	4
142	4	5	5	4	4	4	4	4	4	5	4	3	3	2	5
143	3	3	3	4	4	3	3	3	3	5	4	4	3	4	4
144	5	5	4	4	4	4	4	5	4	5	4	4	3	4	4
145	4	5	4	5	4	5	4	4	4	5	3	3	5	4	4
146	5	5	5	5	5	5	5	5	5	5	5	5	5	5	5
147	4	4	4	5	5	4	4	4	5	4	4	4	3	4	4
148	5	5	5	5	5	4	5	4	5	4	3	3	5	4	4
149	5	5	5	4	4	5	5	5	5	5	4	3	4	4	4
150	4	4	5	4	4	4	5	4	4	5	4	4	4	4	4
151	4	4	4	5	5	4	3	3	3	4	3	2	4	5	3
152	3	3	3	4	4	4	3	3	3	4	5	2	3	2	5
153	4	5	4	5	4	4	5	4	4	5	3	4	3	3	4
154	5	3	3	3	3	3	3	3	3	5	3	3	3	4	3
155	3	4	3	4	4	3	3	3	3	5	4	4	3	4	4
156	5	5	5	4	4	5	5	5	5	5	5	5	5	5	5
157	3	3	3	4	4	4	4	3	3	3	3	2	5	2	5
158	4	2	2	2	2	2	2	2	2	2	3	2	2	2	2
159	4	5	5	5	5	4	5	4	4	5	4	4	4	4	4
160	4	4	3	3	3	2	2	2	3	3	2	3	3	2	2
161	4	5	5	4	4	4	5	4	5	4	3	3	4	4	4
162	4	5	5	5	5	5	5	5	5	5	5	5	5	5	5
163	4	4	4	5	5	4	4	4	5	5	5	5	5	5	5
164	4	4	4	5	4	5	5	4	5	4	5	5	5	5	5
165	4	4	5	5	5	4	5	4	5	4	5	5	5	5	5
166	3	1	1	1	1	1	1	1	2	2	1	1	2	1	2
167	4	5	5	5	4	4	5	4	4	5	4	4	4	5	5
168	3	5	4	2	3	4	2	2	2	2	2	3	3	2	2
169	4	4	5	5	5	5	5	5	5	5	4	4	3	4	4

Lampiran 3 Frekuensi Responden

		Statistics																		
		CG1	CG2	CG3	CG4	CP1	CP2	CP3	CP4	E1	E2	E3	OC1	OC2	OC3	OC4	OC5	EP1	EP2	EP3
N	Valid	170	170	170	170	170	170	170	170	170	170	170	170	170	170	170	170	170	170	170
	Missing	0	0	0	0	0	0	0	0	0	0	0	0	0	0	0	0	0	0	0

CG1

	Frequency	Percent	Valid Percent	Cumulative Percent
Valid 1.00	6	3.5	3.5	3.5
Valid 2.00	20	11.8	11.8	15.3
Valid 3.00	45	26.5	26.5	41.8
Valid 4.00	74	43.5	43.5	85.3
Valid 5.00	25	14.7	14.7	100.0
Total	170	100.0	100.0	

CG2

	Frequency	Percent	Valid Percent	Cumulative Percent
Valid 1.00	11	6.5	6.5	6.5
Valid 2.00	16	9.4	9.4	15.9
Valid 3.00	52	30.6	30.6	46.5
Valid 4.00	61	35.9	35.9	82.4
Valid 5.00	30	17.6	17.6	100.0
Total	170	100.0	100.0	

CG3

	Frequency	Percent	Valid Percent	Cumulative Percent
Valid 1.00	12	7.1	7.1	7.1
Valid 2.00	17	10.0	10.0	17.1
Valid 3.00	50	29.4	29.4	46.5
Valid 4.00	65	38.2	38.2	84.7
Valid 5.00	26	15.3	15.3	100.0
Total	170	100.0	100.0	

CG4

	Frequency	Percent	Valid Percent	Cumulative Percent
Valid 1.00	10	5.9	5.9	5.9
Valid 2.00	19	11.2	11.2	17.1
Valid 3.00	48	28.2	28.2	45.3
Valid 4.00	70	41.2	41.2	86.5
Valid 5.00	23	13.5	13.5	100.0
Total	170	100.0	100.0	

CP1

	Frequency	Percent	Valid Percent	Cumulative Percent
Valid 1.00	5	2.9	2.9	2.9
Valid 2.00	20	11.8	11.8	14.7
Valid 3.00	46	27.1	27.1	41.8
Valid 4.00	63	37.1	37.1	78.8
Valid 5.00	36	21.2	21.2	100.0
Total	170	100.0	100.0	

CP2

	Frequency	Percent	Valid Percent	Cumulative Percent
1.00	7	4.1	4.1	4.1
2.00	19	11.2	11.2	15.3
3.00	42	24.7	24.7	40.0
4.00	67	39.4	39.4	79.4
5.00	35	20.6	20.6	100.0
Total	170	100.0	100.0	

CP3

	Frequency	Percent	Valid Percent	Cumulative Percent
1.00	10	5.9	5.9	5.9
2.00	14	8.2	8.2	14.1
3.00	48	28.2	28.2	42.4
4.00	66	38.8	38.8	81.2
5.00	32	18.8	18.8	100.0
Total	170	100.0	100.0	

CP4

	Frequency	Percent	Valid Percent	Cumulative Percent
.00	1	.6	.6	.6
1.00	6	3.5	3.5	4.1
2.00	16	9.4	9.4	13.5
3.00	37	21.8	21.8	35.3
4.00	63	37.1	37.1	72.4
5.00	47	27.6	27.6	100.0
Total	170	100.0	100.0	

EI1

	Frequency	Percent	Valid Percent	Cumulative Percent
1.00	9	5.3	5.3	5.3
2.00	18	10.6	10.6	15.9
3.00	40	23.5	23.5	39.4
4.00	61	35.9	35.9	75.3
5.00	42	24.7	24.7	100.0
Total	170	100.0	100.0	

EI2

	Frequency	Percent	Valid Percent	Cumulative Percent
1.00	5	2.9	2.9	2.9
2.00	19	11.2	11.2	14.1
3.00	35	20.6	20.6	34.7
4.00	71	41.8	41.8	76.5
5.00	40	23.5	23.5	100.0
Total	170	100.0	100.0	

EI3

	Frequency	Percent	Valid Percent	Cumulative Percent
1.00	8	4.7	4.7	4.7
2.00	17	10.0	10.0	14.7
3.00	35	20.6	20.6	35.3
4.00	69	40.6	40.6	75.9
5.00	41	24.1	24.1	100.0
Total	170	100.0	100.0	

OC1

	Frequency	Percent	Valid Percent	Cumulative Percent
1.00	7	4.1	4.1	4.1
2.00	12	7.1	7.1	11.2
3.00	56	32.9	32.9	44.1
4.00	67	39.4	39.4	83.5
5.00	28	16.5	16.5	100.0
Total	170	100.0	100.0	

OC2

	Frequency	Percent	Valid Percent	Cumulative Percent
1.00	8	4.7	4.7	4.7
2.00	15	8.8	8.8	13.5
3.00	56	32.9	32.9	46.5
4.00	61	35.9	35.9	82.4
5.00	30	17.6	17.6	100.0
Total	170	100.0	100.0	

OC3

	Frequency	Percent	Valid Percent	Cumulative Percent
1.00	7	4.1	4.1	4.1
2.00	20	11.8	11.8	15.9
3.00	44	25.9	25.9	41.8
4.00	76	44.7	44.7	86.5
5.00	23	13.5	13.5	100.0
Total	170	100.0	100.0	

OC4

	Frequency	Percent	Valid Percent	Cumulative Percent
1.00	7	4.1	4.1	4.1
2.00	17	10.0	10.0	14.1
3.00	44	25.9	25.9	40.0
4.00	77	45.3	45.3	85.3
5.00	25	14.7	14.7	100.0
Total	170	100.0	100.0	

OC5

	Frequency	Percent	Valid Percent	Cumulative Percent
1.00	6	3.5	3.5	3.5
2.00	21	12.4	12.4	15.9
Valid 3.00	42	24.7	24.7	40.6
4.00	70	41.2	41.2	81.8
5.00	31	18.2	18.2	100.0
Total	170	100.0	100.0	

EP1

	Frequency	Percent	Valid Percent	Cumulative Percent
1.00	8	4.7	4.7	4.7
2.00	12	7.1	7.1	11.8
Valid 3.00	44	25.9	25.9	37.6
4.00	66	38.8	38.8	76.5
5.00	40	23.5	23.5	100.0
Total	170	100.0	100.0	

EP2

	Frequency	Percent	Valid Percent	Cumulative Percent
1.00	5	2.9	2.9	2.9
2.00	19	11.2	11.2	14.1
Valid 3.00	42	24.7	24.7	38.8
4.00	72	42.4	42.4	81.2
5.00	32	18.8	18.8	100.0
Total	170	100.0	100.0	

EP3

	Frequency	Percent	Valid Percent	Cumulative Percent
1.00	7	4.1	4.1	4.1
2.00	16	9.4	9.4	13.5
Valid 3.00	52	30.6	30.6	44.1
4.00	62	36.5	36.5	80.6
5.00	33	19.4	19.4	100.0
Total	170	100.0	100.0	

Lampiran 4 : CFA VARIABEL LATEN

1. CFA TATA KELOLA KOLABORASI

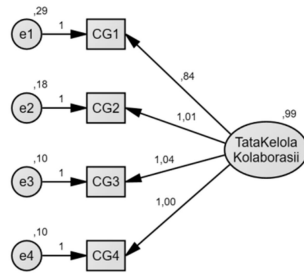

UJI MODEL
 Statistical Measure
 Chi Square=1,760
 Signifikansi=.415
 DF=2
 Non Statistical Measure
 GFI=.995
 CFI=1,000
 TLI=1,001
 RMSEA=.000

2. CFA KOMPETENSI PERSONAL

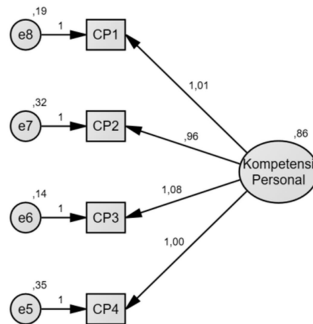

UJI MODEL
 Statistical Measure
 Chi Square=1,039
 Signifikansi=.595
 DF=2
 Non Statistical Measure
 GFI=.997
 CFI=1,000
 TLI=1,005
 RMSEA=.000

3. CFA INTEGRITAS KARYAWAN

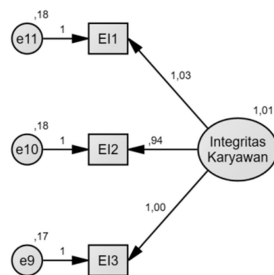

UJI MODEL
 Statistical Measure
 Chi Square=.000
 Signifikansi=.p
 DF=0
 Non Statistical Measure
 GFI=1,000
 CFI=1,000
 TLI=TLI
 RMSEA=RMSEA

4. CFA KOMITMEN ORGANISASI

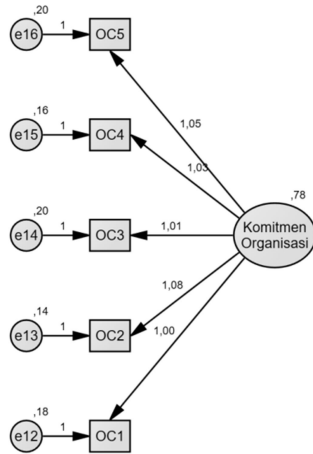

UJI MODEL
 Statistical Measure
 Chi Square=7,763
 Signifikansi=.170
 DF=5
 Non Statistical Measure
 GFI=.982
 CFI=.997
 TLI=.994
 RMSEA=.057

5. CFA KINERJA KARYAWAN

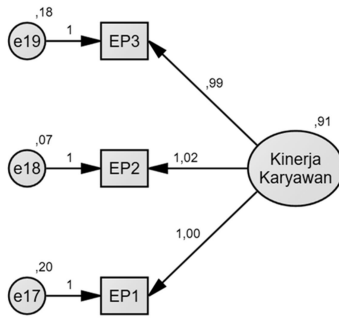

UJI MODEL
 Statistical Measure
 Chi Square=.000
 Signifikansi=>p
 DF=0
 Non Statistical Measure
 GFI=1,000
 CFI=1,000
 TLI=>TLI
 RMSEA=>RMSEA

Lampiran 5: Uji Model dan Pengujian Hipotesis Pengaruh antar variabel secara langsung

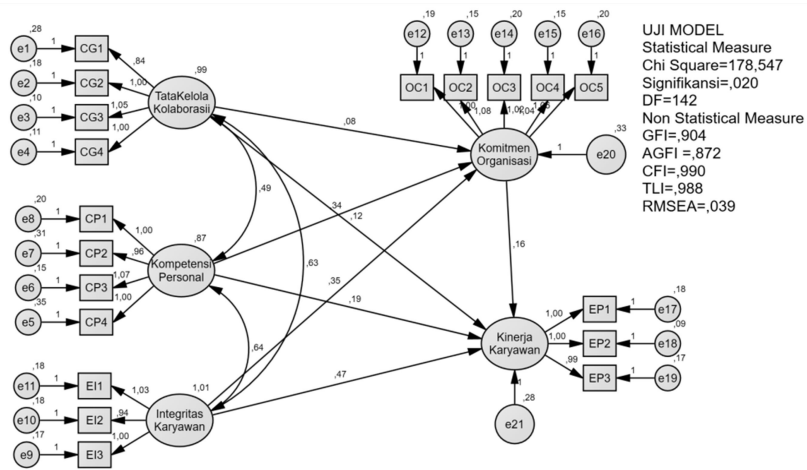

UJI MODEL
 Statistical Measure
 Chi Square=178.547
 Signifikansi=.020
 DF=142
 Non Statistical Measure
 GFI=.904
 AGFI=.872
 CFI=.990
 TLI=.988
 RMSEA=.039

Estimates (Group number 1 - Default model)

Scalar Estimates (Group number 1 - Default model)

Maximum Likelihood Estimates

Regression Weights: (Group number 1 - Default model)

	Estimate	S.E.	C.R.	P	Label
Komitmen_Organisasi <--- TataKelola_Kolaborasi	,075	,065	1,155	,248	par_12
Komitmen_Organisasi <--- Kompetensi_Personal	,342	,078	4,375	***	par_13
Komitmen_Organisasi <--- Integritas_Karyawan	,353	,079	4,459	***	par_14
Kinerja_Karyawan <--- Integritas_Karyawan	,472	,084	5,618	***	par_15
Kinerja_Karyawan <--- Kompetensi_Personal	,193	,079	2,432	,015	par_16
Kinerja_Karyawan <--- TataKelola_Kolaborasi	,116	,063	1,840	,066	par_17
Kinerja_Karyawan <--- Komitmen_Organisasi	,158	,084	1,873	,061	par_18

Standardized Regression Weights: (Group number 1 - Default model)

	Estimate
Komitmen_Organisasi <--- TataKelola_Kolaborasi	,085
Komitmen_Organisasi <--- Kompetensi_Personal	,362
Komitmen_Organisasi <--- Integritas_Karyawan	,403
Kinerja_Karyawan <--- Integritas_Karyawan	,493
Kinerja_Karyawan <--- Kompetensi_Personal	,187
Kinerja_Karyawan <--- TataKelola_Kolaborasi	,120
Kinerja_Karyawan <--- Komitmen_Organisasi	,145

Standardized Indirect Effects (Group number 1 - Default model)

	TataKelola_Kolaborasi	Integritas_Karyawan	Kompetensi_Personal
Komitmen_Organisasi	,000	,000	,000
Kinerja_Karyawan	,012	,058	,053

Standardized Indirect Effects - Two Tailed Significance (BC) (Group number 1 - Default model)

	TataKelola_Kolaborasi	Integritas_Karyawan	Kompetensi_Personal
Komitmen_Organisasi
Kinerja_Karyawan	,200	,057	,048

Lampiran 6: Hasil Uji Mediasi Menggunakan Sobel Test

1. Pengaruh tata kelola kolaborasi terhadap Kinerja karyawan melalui komitmen organisasi

Sobel Test Calculator for the Significance of Mediation

This calculator uses the Sobel test to tell you whether a mediator variable significantly carries the influence of an independent variable to a dependent variable; i.e., whether the indirect effect of the independent variable on the dependent variable through the mediator variable is significant. This calculator returns the Sobel test statistic, and both one-tailed and two-tailed probability values.

Please enter the necessary parameter values, and then click 'Calculate'.

A: 0.36
B: 0.14
SE_A: 0.07
SE_B: 0.08

Calculate!

Sobel test statistic: 1.6567120
One-tailed probability: 0.04878886
Two-tailed probability: 0.09757772

2. Pengaruh kompetensi personal terhadap Kinerja karyawan melalui komitmen organisasi

Sobel Test Calculator for the Significance of Mediation

This calculator uses the Sobel test to tell you whether a mediator variable significantly carries the influence of an independent variable to a dependent variable; i.e., whether the indirect effect of the independent variable on the dependent variable through the mediator variable is significant. This calculator returns the Sobel test statistic, and both one-tailed and two-tailed probability values.

Please enter the necessary parameter values, and then click 'Calculate'.

A: 0.08
B: 0.14
SE_A: 0.06
SE_B: 0.08

Calculate!

Sobel test statistic: 1.06057563
One-tailed probability: 0.14444140
Two-tailed probability: 0.28888280

3. Pengaruh integritas terhadap Kinerja karyawan melalui komitmen organisasi

Sobel Test Calculator for the Significance of Mediation

This calculator uses the Sobel test to tell you whether a mediator variable significantly carries the influence of an independent variable to a dependent variable; i.e., whether the indirect effect of the independent variable on the dependent variable through the mediator variable is significant. This calculator returns the Sobel test statistic, and both one-tailed and two-tailed probability values.

Please enter the necessary parameter values, and then click 'Calculate'.

A: 0.40
B: 0.14
SE_A: 0.07
SE_B: 0.08

Calculate!

Sobel test statistic: 1.67329017
One-tailed probability: 0.04713509
Two-tailed probability: 0.09427019