

DAFTAR PUSTAKA

- Akhyar, H., Iswanto, P. T., dan Pambekti, A. (2018). Pengaruh Variasi Suhu Tuang dengan Heat Treatment T4 terhadap Sifat Mekanis pada Aluminium Paduan 2024, *1*(July), 61–65
- Fauzan (2018). Perencanaan Fender Dermaga (*Jetty*) Kapal Dengan Bobot 10000 DWT, *Vol 1. No. 1 2*(October). <https://jurnal.ensiklopediaku.org>
- Muhammad Zikra, Kriyo, S., Abdul, M.,T., Yeyes, M. (2016). Design and Modeling Fender System For Condensate and Sulphuric Acid Jetty at Senoro Field, Central Sulawesi, ISSN 1819-6608
- Choudhari C.M., Narkhede, B., M., Mahajan, S., K. (2014). Casting Design and Simulation of Cover Plate using AutoCAST-X Software for Detect Minimization with Experimental Validation, *Procedia Materials Science* 6 786-797
- Beeresh Chatrad, Nithin Kammar, Prasanna P Kulkarni, Shrinivas Patil, A study on Minimization of Critical Defects in Casting Process Considering Various Parameters, *International Journal of Innovative research in Science, Engineering and Technology*,5(2016)8884-8902
- Budiyono, A., dan Widayat, W. (2013). Pemanfaatan Aluminium Skrap Sebagai Bahan Baku Industri Kecil Pengecoran Logam Non Ferro Melalui Perlakuan Pada Logam Cair (*Solution Treatment*) Dengan *Rotary Degasser*. *Saintekno*, *11*(1), 21–34. <https://doi.org/10.15294/saintekno.v11i1.5561>
- B. Ravi, Casting method optimization driven by simulation, *Indian Foundry Cong.* 57 (2009) 70–74
- Carlson, K. D., Ou, S., Hardin, R. A., dan Beckermann, C. (2002). Development of new feeding-distance rules using casting simulation: Part I. Methodology. *Metallurgical and Materials Transactions B: Process Metallurgy and Materials Processing Science*, 33(5), 731-740. <https://doi.org/10.1007/s11663-002-0027-0>
- Chelladurai, C., Mohan, N. S., Hariharashayee, D., Manikandan, S., dan Sivaperumal, P. (2020). Analyzing the casting defects in small scale casting industry. *Materials Today: Proceedings*, xxx. <https://doi.org/10.1016/j.matpr.2020.05.32>
- J. Jezierski, R. Dojka, K. Janerka, Optimizing the gating system for steel castings, *Metals* 8 (66) (2018) 1–13

- Kalpakjian, S., *Manufacturing Engineering and Technology*, 7th Pearson Prentice Hall, 2006
- Kotschi R.M., *Metals Handbook: Casting Design*, 9th edition, ASM, 1988
- Lampman, S., (2009). *Casting Design and Performance*. ASM International, 165.
- Budinski G. K., (1996). *Engineering Material Properties and Selection*, Prentice Hall, Inc, Englewood Cliffs, New Jersey.
- Surdia, T.; Saito, S., (2000). *Pengetahuan Bahan Teknik*, Cetakan ke 4, Pt. Pradnya Paramita, Jakarta.
- Supandi, S.; Bandriyana, B., (2008). *Karakterisasi Bahan Paduan Al-Si Hasil Proses Squeeze Casting*, Pusat Teknologi Bahan Industri Nuklir (PTBIN)-BATAN, Tangerang.
- Firdaus., (2002). Analisis Parameter Proses Pengecoran *Squeeze* Terhadap Cacat Porositas Produk Flens Motor Sungai. *Jurnal Teknik Mesin* Vol.4, No.1, pp.6-12.
- Kurniawan, D. Y., Sumarji, dan Kristianta, F. (2014). Simulasi Perancangan Saluran Tuang Pada Pembuatan Pipe Reducer Ø 12'' Ke Ø 10'' FC25 Dengan Perangkat Lunak Solidcast. *Unej Jurnal*, II(2), 1–5
- Nimbulkar, S. L., dan Dalu, R. S. (2016). Design optimization of gating and feeding system through simulation technique for sand casting of wear plate. *Perspectives in Science*, 8, 39–42. <https://doi.org/10.1016/j.pisc.2016.03.001>
- Suardia, T., and Saito, S. (1985a). *Ilmu Pengetahuan Bahan Teknik*. Pradnya Paramita Jakarta.
- Suardia, T., and Saito, S. (1985b). *Ilmu Pengetahuan Bahan Teknik*. Pradnya Paramita Jakarta.
- Suardia, T., *Teknik Pengecoran Logam*, PT. Pradnya Paramita, Jakarta, 1976
- Surekha, B., Rao, D. H., Rao, G. K. M., & Vundavilli, P. R. (2014). Design and Development of Knowledge Base Scheme for Chromite-based Resin Bonded Sand Core System. *Procedia Materials Science*, 6(Icmpc), 919–925. <https://doi.org/10.1016/j.mspro.2014.07.161>
- Zhiyu, Jiang., and Mintong Gu. (2010). Optimization of a fender structure for the crashworthiness design. *School of naval Architecture, Shang hai jiao Tong*

University, No. 800 Dongchuan Road, Shanghai 200240, PR China.
<https://www.elsevier.com/locate/matdes>

- Narayanswamy.C, Natrajan.K, Review Analysis of Casting Defect with Respect to Indian Standards in Cast Iron foundry, *Journal of Chemical and pharmaceutical Science*,2(2016)63-68,ISSN:0974-2115
- Muhammad Zikra, Kriyo Sambodho, T. Abdul Manan, Yeyes Mulyadi, (2016). Design and Modeling Fender System For Condensate and Sulphuric Acid Jetty At Senoro Field, Central Sulawesi, *ARPN Journal of Engineering and Applied Sciences*, <https://www.arpnjournals.com>
- Budiyono, A., dan Widayat, W. Pemanfaatan Aluminium Skrap Sebagai Bahan Baku Industri Kecil Pengecoran Logam Non Ferro Melalui Perlakuan Pada Logam Cair (Solution Treatment) Dengan Rotary Degasser. *Saintekno*, 11(1), 21-34. <https://doi.org/10.15294/saintekno.v11i1.5561> (2013)
- W.,T., Bhirawa. Proses Pengecoran Logam Dengan Menggunakan Sand Casting. Program Studi Teknik Industri Universitas Suryadarma, Jakarta. (2021)
- Hirigo, T. H., & Singh, B. Design and Analysis of sand casting process of mill roller. *International Journal of advanced Manufacturing Technology*, 105(5-6), 2183-2214. <https://doi.org/10.1007/s00170-019-04270-4> (2019).
- Glasbrenner, Scale Structure of Aluminized F82H-mod after HIP Treatment. Elsevier,2000.
- Hagayeghi., R. Bahai., Kapranos, H., 2012. Effect of Ultrasonic argon degassing on dissolved hydrogen in aluminium alloy, *materials Letter* 82, hlm. 230-232.
- Kucharikova, L., & Tillova, E. The comparison of the porosity formation in different casted secondary aluminium alloy. *Zeszyty Naukowe Quality. Production. Improvement I(I)*, 2-9 (2017)
- KS, R.P., Siahaan, E., and Darmawan, S. Pengaruh unsur Silikon Pada Aluminium Alloy (al-si) Terhadap Sifat Mekanis dan Struktur Mikro. *Poros* 14,49-56 (2017).
- Narwanto, I., Studi, P., Mesin, T., Teknik, F., & Surakarta, u. Studi pengamatan density dan struktur mikro Scanned by camscanner (2020)
- Muhammad Syahid, Andi Amijoyo Muchtar, & A., Ari Putra. Perancangan Gating System Flange Reducer Dengan Media Pasir Resin (Resin Coated Sand). *EPI International Journal of Engineering*, Volume 1, Number 1, pp 1-2. DOI: 10.25042/epi-ije.022018.01, 1 February 2018.

LAMPIRAN

Lampiran 1 Gambar Desain *Fender*

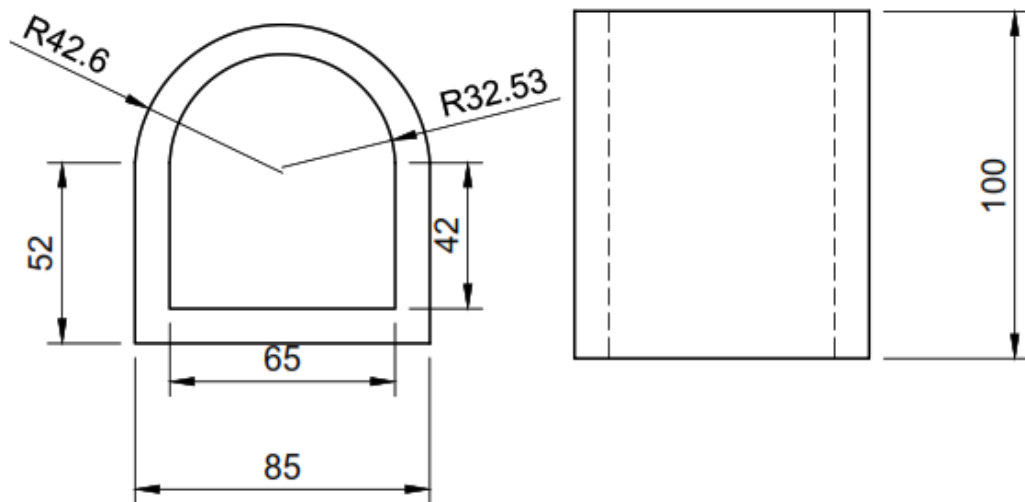
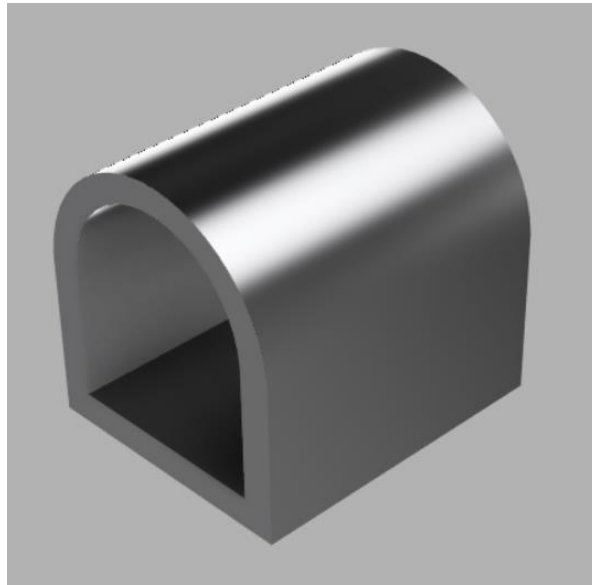

Lampiran 2 Foto Kegiatan

Proses Pembuatan Cetakan



Pemasangan pola cetakan kayu



Proses pengayakan pasir silika



Hasil Pembuatan cetakan pasir bagian atas dan bawah

Proses Pembuatan Inti Cor



Proses pembakaran inti cor

Proses Pengecoran



Proses peleburan aluminium



Saluran masuk cairan logam



Proses penuangan aluminium cair pada cetakan



Hasil Pengecoran *Fender*

Proses Pengujian

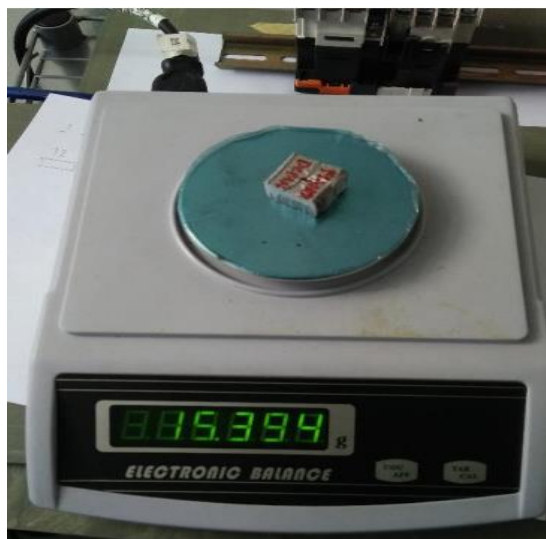

Penimbangan berat Sampel

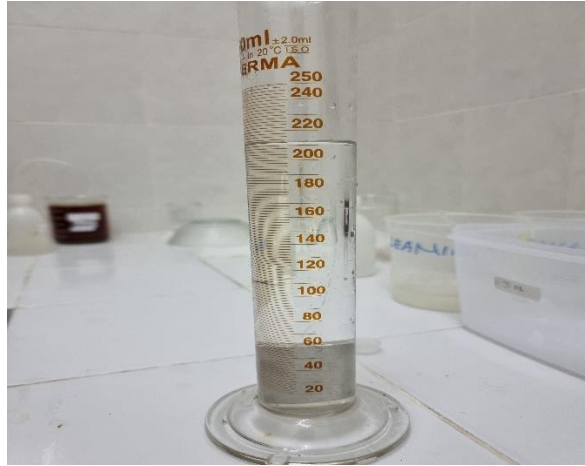

Pengukuran penambahan Volume



Proses pengujian kekerasan