

DAFTAR PUSTAKA

- Adam, Z., Ameme, D. K., Nortey, P., Afari, E. A. & Kenu, E. (2019). Determinants of low birth weight in neonates born in three hospitals in Brong Ahafo region, Ghana 2016- an unmatched case-control study. *BMC Pregnancy Childbirth*, 19, 1–9.
- Agapova, S., Stephenson, K., Manary, M., Weisz, A., Tarr, P. I., Mkakosya, R., Maleta, K., Shulman, R. J., Manary, M., & Shaikh, N. (2013). Detection of low-concentration host mRNA transcripts in Malawian children at risk for environmental enteropathy. *Journal of Pediatric Gastroenterology and Nutrition*, 56(1), 66–71.
- Aliyu, M.H., Luke, S., Kristensen, S., Alio, A.P., & Salihu, H. (2012). The factor list of low birth weight: a population based study In Karachi. *J. Adolesc Heal*, 46, 77–82.
- Arndt, M. B., Richardson, B. A., Ahmed, T., Mahfuz, M., Haque, R., John-Stewart, G. C., Denno, D. M., Petri Jr, W. A., Kosek, M., & Walson, J. L. (2016). Fecal markers of environmental enteropathy and subsequent growth in Bangladeshi children. *The American Journal of Tropical Medicine and Hygiene*, 95(3), 694.
- Assefa, N., Berhane, Y., & Worku, A. (2012). Wealth status, mid upper arm circumference (MUAC) and antenatal care (ANC) are determinants for low birth weight in Kersa, Ethiopia. *PloS One*, 7(6), e39957.
- Baker, K. K., Story, W. T., Walser-Kuntz, E., & Zimmerman, M. B. (2018). Impact of social capital, harassment of women and girls, and water and sanitation access on premature birth and low infant birth weight in India. *PloS One*, 13(10), e0205345.
- Baker KK, Padhi BK, Torondel B, Das P, Dutta A, Sahoo KC, et al. (2017). From Menarche to Menopause: A Population-Based Assessment of Water, Sanitation, and Hygiene Risk Factors for Reproductive Tract Infection Symptoms over Life stages in rural Girls and Women in India. *PLoS One*.
- Benova L, Cumming O, C. O. (2014). Systematic review and meta-analysis: association between water and sanitation environment and maternal mortality. *Trop Med Int Health.*, 19(4), 368–87.
- Benova, L., Cumming, O., & Campbell, O. M. R. (2014). Systematic review and meta-analysis: association between water and sanitation environment and maternal mortality. *Tropical Medicine & International Health*, 19(4), 368–387.

- Black, R. E., Victora, C. G., Walker, S. P., Bhutta, Z. A., Christian, P., De Onis, M., Ezzati, M., Grantham-McGregor, S., Katz, J., & Martorell, R. (2013). Maternal and child undernutrition and overweight in low-income and middle-income countries. *The Lancet*, *382*(9890), 427–451.
- Breton, J., Massart, S., Vandamme, P., De Brandt, E., Pot, B., & Foligné, B. (2013). Ecotoxicology inside the gut: impact of heavy metals on the mouse microbiome. *BMC Pharmacology and Toxicology*, *14*(1), 1–11.
- Budge, S., Parker, A. H., Hutchings, P. T., & Garbutt, C. (2019). Environmental enteric dysfunction and child stunting. *Nutrition Reviews*, *77*(4), 240–253. <https://doi.org/10.1093/nutrit/nuy068>
- Budjang, R. . (2015). *Bayi dengan berat Lahir Rendah* (dalam Ilmu). EGC. Jakarta.
- Campbell, R. K., Schulze, K. J., Shaikh, S., Raqib, R., Wu, L. S. F., Ali, H., Mehra, S., West, K. P., & Christian, P. (2018). Environmental enteric dysfunction and systemic inflammation predict reduced weight but not length gain in rural Bangladeshi children. *British Journal of Nutrition*, *119*(4), 407–414. <https://doi.org/10.1017/S0007114517003683>
- Campbell, R. K., Schulze, K., Shaikh, S., Mehra, S., Ali, H., Wu, L., Raqib, R., Baker, S., Labrique, A., & West Jr, K. P. (2017). Biomarkers of environmental enteric dysfunction among children in rural Bangladesh. *Journal of Pediatric Gastroenterology and Nutrition*, *65*(1), 40.
- Caruso BA, Sevilimedu V, Fung IC, Patkar A, B. K. (2015). Gender disparities in water, sanitation, and global health. *Lancet*, *386*(9990), 650–651.
- Checkley, W., Buckley, G., Gilman, R. H., Assis, A. M. O., Guerrant, R. L., Morris, S. S., Mølbak, K., Valentiner-Branth, P., Lanata, C. F., & Black, R. E. (2008). Multi-country analysis of the effects of diarrhoea on childhood stunting. *International Journal of Epidemiology*, *37*(4), 816–830.
- Checkley, W., Epstein, L. D., Gilman, R. H., Black, R. E., Cabrera, L., & Sterling, C. R. (1998). Effects of *Cryptosporidium parvum* infection in Peruvian children: growth faltering and subsequent catch-up growth. *American Journal of Epidemiology*, *148*(5), 497–506.
- Chen, P., Soares, A. M., Lima, A. A. M., Gamble, M. V, Schorling, J. B., Conway, M., Barrett, L. J., Blaner, W. S., & Guerrant, R. L. (2003). Association of vitamin A and zinc status with altered intestinal permeability: analyses of cohort data from northeastern Brazil. *Journal of Health, Population and Nutrition*, 309–315.
- ClinicalTrials.gov. (2018). *Identifier NCT03588013, Study of Environmental Enteropathy and Malnutrition in Pakistan (SEEM)*.

<https://clinicaltrials.gov/ct2/show/NC>.

- Crane, R. J., Jones, K. D. J., & Berkley, J. A. (2015). Environmental enteric dysfunction: an overview. *Food and Nutrition Bulletin*, 36(1_suppl1), S76–S87.
- Cumming, O., Jeandron, A., & Ensink, J. (2012). *Trachoma & WASH: an evidence summary (prepared for DFID)*.
- Cumming, Oliver, Watson, L., & Dangour, A. (2016). Water, sanitation and hygiene: a missing link to food and nutrition security? In *Routledge Handbook of Food and Nutrition Security* (pp. 460–472). Routledge.
- Cunningham, F.G., Leveno, K.J., Bloom, S.L., Hauth, J.C., Gilstrap III, L. C., & Wenstrom, K. D. (2014). *Williams obstetrics* (22nd ed.).
- Dangour, A. D., Watson, L., Cumming, O., Boisson, S., Che, Y., Velleman, Y., Cavill, S., Allen, E., & Uauy, R. (2013). Interventions to improve water quality and supply, sanitation and hygiene practices, and their effects on the nutritional status of children. *Cochrane Database of Systematic Reviews*, 8.
- Das P, Baker KK, Dutta A, Swain T, Sahoo S, Das BS, et al. (2015). Menstrual Hygiene Practices, WASH Access and the Risk of Urogenital Infection in Women from Odisha, India. *PLoS One*, 10(6).
- De Filippo, C., Cavalieri, D., Di Paola, M., Ramazzotti, M., Poullet, J. B., Massart, S., Collini, S., Pieraccini, G., & Lionetti, P. (2010). Impact of diet in shaping gut microbiota revealed by a comparative study in children from Europe and rural Africa. *Proceedings of the National Academy of Sciences*, 107(33), 14691–14696.
- Denno, D. M., Tarr, P. I., & Nataro, J. P. (2017). Environmental enteric dysfunction: a case definition for intervention trials. *The American Journal of Tropical Medicine and Hygiene*, 97(6), 1643.
- Denno, D. M., Van Buskirk, K. M., Nelson, Z. C., Musser, C. A., & Tarr, P. I. (2016). *Environmental enteric dysfunction: advancing current knowledge*. Washington University Libraries.
- Denno DM, VanBuskirk K, Nelson ZC, Musser CA, Hay Burgess DC, T. P. (2014). Use of the lactulose to mannitol ratio to evaluate childhood environmental enteric dysfunction: a systematic review. *Clin Infect Dis*, 59(4), S213–S219.
- Dinari G, Rosenbach Y, Zahavi I, Sivan Y, N. M. (1984). Random Fecal Alpha1- Antitrypsin Excretion in Children With Intestinal Disorders. *Am J Dis Child*, 138, 971-3.
- ED., N. (2010). Diarrhoea and malnutrition. *J Clin Nutr*, 23:(S15-S8).

- Eno, E., Fawole, A., Aboyeji, P., Adesina, K., & Adeniran, A. (2014). *Domestic violence and obstetric outcome among pregnant women in Ilorin, north central Nigeria*.
- Esplin MS, Manuck TA, Varner MW, Christensen B, Biggio J, Bukowski R, et al. (2015). Cluster analysis of spontaneous preterm birth phenotypes identifies potential associations among preterm birth mechanisms. *Am J Obstet Gynecol*, 213(3), 429. [https://doi.org/Epub 2015/06/14](https://doi.org/Epub%202015/06/14)
- Exum, N. G., Lee, G. O., Olórtegui, M. P., Yori, P. P., Salas, M. S., Trigos, D. R., Colston, J. M., Schwab, K. J., McCormick, B. J. J., & Kosek, M. N. (2018). A longitudinal study of household water, sanitation, and hygiene characteristics and environmental enteropathy markers in children less than 24 months in Iquitos, Peru. *The American Journal of Tropical Medicine and Hygiene*, 98(4), 995.
- Fahim, S. M., Das, S., Sanin, K. I., Gazi, M. A., Mahfuz, M., Munirul Islam, M., & Ahmed, T. (2018). Association of fecal markers of environmental enteric dysfunction with zinc and iron status among children at first two years of life in Bangladesh. *American Journal of Tropical Medicine and Hygiene*, 99(2), 489–494. <https://doi.org/10.4269/ajtmh.17-0985>
- Faubion, W. A., Camilleri, M., Murray, J. A., Kelly, P., Amadi, B., Kosek, M. N., Enders, F., Larson, J., Grover, M., & Boe, G. (2016). Improving the detection of environmental enteric dysfunction: a lactulose, rhamnase assay of intestinal permeability in children aged under 5 years exposed to poor sanitation and hygiene. *BMJ Global Health*, 1(1), e000066.
- Feng, Y., Xu, J., Zhou, Q., Wang, R., Liu, N., Wu, Y., Yuan, H., & Che, H. (2016). Alpha-1 antitrypsin prevents the development of preeclampsia through suppression of oxidative stress. *Frontiers in Physiology*, 7, 176.
- Geere, J.-A. L., Hunter, P. R., & Jagals, P. (2010). Domestic water carrying and its implications for health: a review and mixed methods pilot study in Limpopo Province, South Africa. *Environmental Health*, 9(1), 1–13.
- Geere JA, Hunter PR, J. P. (2010). Domestic water carrying and its implications for health: a review and mixed methods pilot study in Limpopo Province, South Africa. *Environ Health*, 9(52).
- Georgiou, H. M., Thio, Y. S., Russell, C., Permezel, M., Heng, Y. J., Lee, S., & Tong, S. (2011). Association between maternal serum cytokine profiles at 7-10 weeks' gestation and birthweight in small for gestational age infants. *American Journal of Obstetrics and Gynecology*, 204(5), 415-e1.
- Ghosh, S., Spielman, K., Kershaw, M., Ayele, K., Kidane, Y., Zillmer, K., Wentworth, L., Pokharel, A., Griffiths, J. K., & Belachew, T. (2019).

- Nutrition-specific and nutrition-sensitive factors associated with mid-upper arm circumference as a measure of nutritional status in pregnant Ethiopian women: implications for programming in the first 1000 days. *PloS One*, 14(3), e0214358.
- Gordon, J. I., Dewey, K. G., Mills, D. A., & Medzhitov, R. M. (2012). The human gut microbiota and undernutrition. *Science Translational Medicine*, 4(137), 137ps12-137ps12.
- Goto, R., Panter-Brick, C., Northrop-Clewes, C. A., Manahdhar, R., & Tuladhar, N. R. (2002). Poor intestinal permeability in mildly stunted Nepali children: associations with weaning practices and *Giardia lamblia* infection. *British Journal of Nutrition*, 88(2), 141–149.
- Gough, E. K., Moulton, L. H., Mutasa, K., Ntozini, R., Stoltzfus, R. J., Majo, F. D., Smith, L. E., Panic, G., Giallourou, N., & Jamell, M. (2020). Effects of improved water, sanitation, and hygiene and improved complementary feeding on environmental enteric dysfunction in children in rural Zimbabwe: A cluster-randomized controlled trial. *PLoS Neglected Tropical Diseases*, 14(2), e0007963.
- Grote NK, Bridge JA, Gavin AR, Melville JL, Iyengar S, K. W. (2010). A meta-analysis of depression during pregnancy and the risk of preterm birth, low birth weight, and intrauterine growth restriction. *Arch Gen Psychiatry*, 67(10), 1012–24. <https://doi.org/pub/2010/10/06>
- Guerrant, R. L., Leite, A. M., Pinkerton, R., Medeiros, P. H. Q. S., Cavalcante, P. A., DeBoer, M., Kosek, M., Duggan, C., Gewirtz, A., & Kagan, J. C. (2016). Biomarkers of environmental enteropathy, inflammation, stunting, and impaired growth in children in northeast Brazil. *PloS One*, 11(9), e0158772.
- Guerrant RL, DeBoer MD, Moore SR, Scharf RJ, L. A. (2013). The impoverished gut—a triple burden of diarrhoea, stunting and chronic disease. *Nat Rev Gastroenterol Hepatol*, 10(4), 220–229.
- Haghighi, P., Wolf, P. L., & Durie, P. (1997). Tropical sprue and subclinical enteropathy: a vision for the nineties. *Critical Reviews in Clinical Laboratory Sciences*, 34(4), 313–341.
- Halaby H, Bakheet SM, Shabib S, Powe JE, Mehaidib AA, N. H. (2000). Serum Albumin Scans in Children with Protein-Losing Enteropathy. *The Journal Of Nuclear Medicine*, 43, 251–259.
- Hanaruddin, D. Y. (2021). Desain penelitian kesehatan. In P. P. R. Yohannes (Ed.), *Metodologi penelitian kesehatan* (pp. 67–87). Yayasan Penerbit Muhammad Zaini.
- Harper, K. M., Mutasa, M., Prendergast, A. J., Humphrey, J., & Manges, A. R. (2018). Environmental enteric dysfunction pathways and child

- stunting: A systematic review. *PLoS Neglected Tropical Diseases*, 12(1), 1–23. <https://doi.org/10.1371/journal.pntd.0006205>
- Hasibuan, F. E. B., & Kolondam, B. J. (2017). Interaksi antara Mikrobiota Usus dan Sistem Kekebalan Tubuh Manusia. *Jurnal Ilmiah Sains*, 17(1), 35–42.
- Hlaing, T. (1993). Ascariasis and childhood malnutrition. *Parasitology*, 107(S1), S125–S136.
- Hooper, L.V., Littman, DR., Macpherson, A. J. 2012. (2012). *Interactions between in microbiota and the immune system*.
- Hulland KR, Chase RP, Caruso BA, Swain R, Biswal B, Sahoo KC, et al. (2015). Sanitation, Stress, and Life Stage: A Systematic Data Collection Study among Women in Odisha, India. *PLoS One*, 10(11).
- Humphrey, J. H. (2009). Child undernutrition, tropical enteropathy, toilets, and handwashing. *Lancet*, 374, 1032–1035.
- I, P. (2010). *Bayi dengan Berat Bayi Lahir Rendah (BBLR)*. Nuha Medika. Yogyakarta.
- Investigators Mal-Ed Network. (2017). Childhood stunting in relation to the pre-and postnatal environment during the first 2 years of life: the MAL-ED longitudinal birth cohort study. *PLoS Medicine*, 14(10), e1002408.
- Iqbal, N. T., Sadiq, K., Syed, S., Akhund, T., Umrani, F., Ahmed, S., Yakoob, M. Y., Rahman, N., Qureshi, S., & Xin, W. (2018). Promising biomarkers of environmental enteric dysfunction: a prospective cohort study in Pakistani children. *Scientific Reports*, 8(1), 1–10.
- Iskandar WJ, Sukardi W, S. Y. (2015). Risk of nutritional status on diarrhea among under five children. *Paediatr Indone*, 55, 235-8.
- Israel, M., Albert, J., & Annis, J. (2018). *Toward a hygienic environment for infants and young children: a review of the literature*.
- Kamada, N., Seo, S., Chen, G., dan N. G. (2013). Role of the gut microbiota in immunity and inflammatory disease. *Nature Reviews Immunology*, 5(13), 321–335.
- Kamariyah, N. & M. (2016). Lingkar lengan atas akan memengaruhi penambahan berat badan bayi lahir di BPS ardiningsih Surabaya. *J. Ilmu Kesehatan*, 9, 99–105.
- Kates, N., Mazowita, G., Lemire, F., Jayabarathan, A., Bland, R., Selby, P., Isomura, T., Craven, M., Gervais, M., & Audet, D. (2011). The evolution of collaborative mental health care in Canada: A shared vision for the future. *Canadian Journal of Psychiatry*, 56(5), 11.
- Kelly P, Besa E, Zyambo K, et al. (2016). Endomicroscopic and

transcriptomic analysis of impaired barrier function and malabsorption in environmental enteropathy. *PLoS Negl Trop Dis*.

- Kelly P, Menzies I, Crane R, et al. (2004). Responses of small intestinal architecture and function over time to environmental factors in a tropical population. *Am J Trop Med Hyg.*, 70(4), 412–419.
- Kelly, P., Menzies, I., Crane, R., Zulu, I., Nickols, C., Feakins, R., Mwansa, J., Mudenda, V., Katubulushi, M., & Greenwald, S. (2004). Responses of small intestinal architecture and function over time to environmental factors in a tropical population. *The American Journal of Tropical Medicine and Hygiene*, 70(4), 412–419.
- Kemenkes RI. (2018). Hasil Utama Riset Kesehatan Dasar (RisKesDas). *Kementrian Kesehatan Republik Indonesia*, 1(1), 1–200. <https://doi.org/10.24607/2549-9996.v1i1.p1-200> Desember 2013
- Keusch, G. T., Denno, D. M., Black, R. E., Duggan, C., Guerrant, R. L., Lavery, J. V., Nataro, J. P., Rosenberg, I. H., Ryan, E. T., Tarr, P. I., Ward, H., Bhutta, Z. A., Coovadia, H., Lima, A., Ramakrishna, B., Zaidi, A. K. M., Hay Burgess, D. C., & Brewer, T. (2014). Environmental enteric dysfunction: Pathogenesis, diagnosis, and clinical consequences. *Clinical Infectious Diseases*, 59(Suppl 4), S207–S212. <https://doi.org/10.1093/cid/ciu485>
- Keusch, G. T., Plaut, A. G., & Troncale, F. J. (1972). Subclinical malabsorption in Thailand. II. Intestinal absorption in American military and Peace Corps personnel. *The American Journal of Clinical Nutrition*, 25(10), 1067–1073.
- Keusch, G. T., Rosenberg, I. H., Denno, D. M., Duggan, C., Guerrant, R. L., Lavery, J. V., Tarr, P. I., Ward, H. D., Black, R. E., & Nataro, J. P. (2013). Implications of acquired environmental enteric dysfunction for growth and stunting in infants and children living in low-and middle-income countries. *Food and Nutrition Bulletin*, 34(3), 357–364.
- Keusch GT, Denno DM, Black RE, et al. (2014a). *Environmental enteric dysfunction: pathogenesis, diagnosis, and clinical consequences*.
- Keusch GT, Denno DM, Black RE, et al. (2014b). Environmental enteric dysfunction: pathogenesis, diagnosis, and clinical consequences. *Clin Infect Dis*, 59(4), S207–S212.
- Khoiriah, A. (2017). Hubungan Antara Usia Ibu dan Paritas Ibu Bersalin dengan Berat Bayi Lahir Rendah (BBLR) Di RS. Siti Khadijah Palembang. *J. Kesehat*, 8, 310–314.
- Kline, R. B. (2005). Principles and practice of structural equation modelling. New York. *Guilford Press*, 10, 1049731509336986.

- Korpe, P. S., & Petri, W. A. (2012). Environmental enteropathy: Critical implications of a poorly understood condition. *Trends in Molecular Medicine*, 18(6), 328–336. <https://doi.org/10.1016/j.molmed.2012.04.007>
- Kosek M, Guerrant RL, Kang G, et al. (2014). Assessment of environmental enteropathy in the MAL-ED cohort study: theoretical and analytic framework. *Clin Infect Dis*, 59(Suppl 4)[PubMed: 25305293].
- Kosek M, Haque R, Lima A, et al. (2013a). Fecal markers of intestinal inflammation and permeability associated with the subsequent acquisition of linear growth deficits in infants. *Am J Trop Med Hyg*. [PubMed: 23185075], [PubMed: 2.
- Kosek M, Haque R, Lima A, et al. (2013b). MAL-ED Network. Fecal markers of intestinal inflammation and permeability associated with the subsequent acquisition of linear growth deficits in infants. *Am J Trop Med Hyg*, 88(2), 390–396.
- Kosek, M. N., Ahmed, T., Bhutta, Z., Caulfield, L., Guerrant, R., Houpt, E., Kang, G., Kosek, M., Lee, G., & Lima, A. (2017). Causal pathways from enteropathogens to environmental enteropathy: findings from the MAL-ED birth cohort study. *EBioMedicine*, 18, 109–117.
- Kramer, M. S. (2012). Determinants of low birth weight: methodological assessment and meta-analysis. *Bulletin of the World Health Organization*, 65(5), 663. <http://www.ncbi.nlm.nih.gov/pubmed/3322602>
- Kuzawa, C. W., Fried, R. L., Borja, J. B., & McDade, T. W. (2017). Maternal pregnancy C-reactive protein predicts offspring birth size and body composition in metropolitan Cebu, Philippines. *Journal of Developmental Origins of Health and Disease*, 8(6), 674–681.
- Langford, R., Lunn, P., & Brick, C. P. (2011). Hand-washing, subclinical infections, and growth: A longitudinal evaluation of an intervention in Nepali slums. *American Journal of Human Biology*, 23(5), 621–629.
- Lauer, J. M., Duggan, C. P., Ausman, L. M., Griffiths, J. K., Webb, P., Agaba, E., Nshakira, N., Tran, H. Q., Gewirtz, A. T., & Ghosh, S. (2018). Biomarkers of maternal environmental enteric dysfunction are associated with shorter gestation and reduced length in newborn infants in Uganda. *American Journal of Clinical Nutrition*, 108(4), 889–896. <https://doi.org/10.1093/ajcn/nqy176>
- Lauer, J. M., Duggan, C. P., Ausman, L. M., Griffiths, J. K., Webb, P., Bashaasha, B., Agaba, E., Turyashemerwa, F. M., & Ghosh, S. (2018). Unsafe drinking water is associated with environmental enteric dysfunction and poor growth outcomes in young children in rural southwestern Uganda. *American Journal of Tropical Medicine and*

Hygiene, 99(6), 1606–1612. <https://doi.org/10.4269/ajtmh.18-0143>

- Lima, N. L., Soares, A. M., Mota, R. M. S., Monteiro, H. S. A., Guerrant, R. L., & Lima, A. A. M. (2007). Wasting and Intestinal Barrier Function in Children Taking Alanyl-Glutamine–Supplemented Enteral Formula. *Journal of Pediatric Gastroenterology and Nutrition*, 44(3), 365–374.
- Lin, A., Arnold, B. F., Afreen, S., Goto, R., Huda, T. M. N., Haque, R., Raqib, R., Unicomb, L., Ahmed, T., & Colford Jr, J. M. (2013). Household environmental conditions are associated with enteropathy and impaired growth in rural Bangladesh. *The American Journal of Tropical Medicine and Hygiene*, 89(1), 130.
- Lindenbaum, J., Gerson, C. D., & Kent, T. H. (1971). Recovery of small-intestinal structure and function after residence in the tropics: I. Studies in Peace Corps Volunteers. *Annals of Internal Medicine*, 74(2), 218–222.
- Lindenbaum, J., KENT, T. H., & Sprinz, H. (1966). Malabsorption and jejunitis in American Peace Corps volunteers in Pakistan. *Annals of Internal Medicine*, 65(6), 1201–1209.
- Lisowska-Myjak B, Pachecka J, Sokrates O, Brzozowska-Binda A, T., & E. (1998a). Fecal Alpha-1-Antitrypsin Excretion in Children with Diarrhea. *Scand J Gastroenterol*, 33, 255–259.
- Lisowska-Myjak B, Pachecka J, Sokrates O, Brzozowska-Binda A, T., & E. (1998b). Fecal Alpha-1-Antitrypsin Excretion in Children with Diarrhea. *Scand J Gastroenterol*, 33, 255–259.
- Liu, J., Gratz, J., Amour, C., Nshama, R., Walongo, T., Maro, A., Mduma, E., Platts-Mills, J., Boisen, N., & Nataro, J. (2016). Optimization of quantitative PCR methods for enteropathogen detection. *PloS One*, 11(6), e0158199.
- Liu, J., Platts-Mills, J. A., Juma, J., Kabir, F., Nkeze, J., Okoi, C., Operario, D. J., Uddin, J., Ahmed, S., & Alonso, P. L. (2016). Use of quantitative molecular diagnostic methods to identify causes of diarrhoea in children: a reanalysis of the GEMS case-control study. *The Lancet*, 388(10051), 1291–1301.
- Louis-Auguste, J., Greenwald, S., Simuyandi, M., Soko, R., Banda, R., & Kelly, P. (2014). High dose multiple micronutrient supplementation improves villous morphology in environmental enteropathy without HIV enteropathy: results from a double-blind randomised placebo controlled trial in Zambian adults. *BMC Gastroenterology*, 14(1), 1–10.
- Louis-Auguste, J., & Kelly, P. (2017). Tropical enteropathies. *Current Gastroenterology Reports*, 19(7), 29.

- Lunn, P G, & Northrop-Clewes, C. A. (1993). The impact of gastrointestinal parasites on protein-energy malnutrition in man. *Proceedings of the Nutrition Society*, 52(1), 101–111.
- Lunn, Peter G, Erinoso, H. O., Northrop-Clewes, C. A., & Boyce, S. A. (1999). *Giardia intestinalis* is unlikely to be a major cause of the poor growth of rural Gambian infants. *The Journal of Nutrition*, 129(4), 872–877.
- Lwanga, S. K., Lemeshow, S., & Organization, W. H. (1991). *Sample size determination in health studies: a practical manual*. World Health Organization.
- Mahfuz, M., Das, S., Mazumder, R. N., Rahman, M. M., Haque, R., Bhuiyan, M. M. R., Akhter, H., Sarker, M. S. A., Mondal, D., & Muaz, S. S. A. (2017). Bangladesh Environmental Enteric Dysfunction (BEED) study: protocol for a community-based intervention study to validate non-invasive biomarkers of environmental enteric dysfunction. *BMJ Open*, 7(8), e017768.
- Makassar., D. K. K. (2016). *Profil Kesehatan Kota Makassar 2015*.
- Makhseed, M., Raghupathy, R., El-Shazly, S., Azizieh, F., Al-Harmi, J. A., & Al-Azemi, M. M. K. (2003). Pro-inflammatory maternal cytokine profile in preterm delivery. *American Journal of Reproductive Immunology*, 49(5), 308–318.
- Mallisa, B. & Towidjojo, V. D. (2014). Hubungan Antara Preeklampsia Dengan Kejadian Bayi Berat Badan Lahir Rendah (BBLR) Di Rsud Undata Palu. *J. Ilm. Kedokt*, 1, 1–7.
- Manary, M. J., Abrams, S. A., Griffin, I. J., Quimper, M. M., Shulman, R. J., Hamzo, M. G., Chen, Z., Maleta, K., & Manary, M. J. (2010). Perturbed zinc homeostasis in rural 3–5-y-old Malawian children is associated with abnormalities in intestinal permeability attributed to tropical enteropathy. *Pediatric Research*, 67(6), 671–675.
- Manuaba, I. B. G. (1999). *Anatomi Saluran Kencing*. EGC, Jakarta.
- Manuck TA, Esplin MS, Biggio J, Bukowski R, Parry S, Zhang H, et al. (2015). The phenotype of spontaneous preterm birth: application of a clinical phenotyping tool. *Am J Obstet Gynecol*, 212(4), 487.
- Mapesa, J. O., Maxwell, A. L., & Ryan, E. P. (2016). An exposome perspective on environmental enteric dysfunction. *Environmental Health Perspectives*, 124(8), 1121–1126.
- McGrath, C. J., Arndt, M. B., & Walson, J. L. (2017). Biomarkers to stratify

- risk groups among children with malnutrition in resource-limited settings and to monitor response to intervention. *Hormone Research in Paediatrics*, 88(1), 111–117.
- McKay, S., Gaudier, E., Campbell, D. I., Prentice, A. M., & Albers, R. (2010). Environmental enteropathy: new targets for nutritional interventions. *International Health*, 2(3), 172–180.
- Megazzu G, Jacono G, Pasquale GD, et a. (1985). Reliability and usefulness of random fecal alpha-1 antitrypsin concentration : Further simplification of the method. . . *Journal of Pediatric Gastroenterology and Nutrition*, 4, 402-7.
- Messer LC, Vinikoor LC, Laraia BA, Kaufman JS, Eyster J, Holzman C, et al. (2008). Socioeconomic domains and associations with preterm birth. *Soc Sci Med*, 67(8), 1247–1257. [https://doi.org/Epub 2008/07/22](https://doi.org/Epub%202008/07/22)
- Mills, J. E., & Cumming, O. (2017). *The impact of WASH on key health & social outcomes—review of evidence. SHARE/UNICEF; 2016.*
- Mondal, D., Minak, J., Alam, M., Liu, Y., Dai, J., Korpe, P., Liu, L., Haque, R., & Petri Jr, W. A. (2012). Contribution of enteric infection, altered intestinal barrier function, and maternal malnutrition to infant malnutrition in Bangladesh. *Clinical Infectious Diseases*, 54(2), 185–192.
- Mondal, D., Petri Jr, W. A., Sack, R. B., Kirkpatrick, B. D., & Haque, R. (2006). Entamoeba histolytica-associated diarrheal illness is negatively associated with the growth of preschool children: evidence from a prospective study. *Transactions of the Royal Society of Tropical Medicine and Hygiene*, 100(11), 1032–1038.
- Morais, M. B. de, & Silva, G. A. P. da. (2019). Environmental enteric dysfunction and growth☆. *Jornal de Pediatria*, 95, S85–S94.
- Nagra, N., & Dang, S. (2019). *Protein Losing Enteropathy.*
- Ncube CN, Enquobahrie DA, Albert SM, Herrick AL, B. J. (2016). Association of neighborhood context with offspring risk of preterm birth and low birthweight: A systematic review and meta-analysis of population-based studies. *Soc Sci Med, Epub 2016/(153)*, 156–164.
- Ni Nyoman Hartati, I Dewa Ayu Ketut Surinati, N. N. D. V. P. (2018). Preeklampsia Dengan Berat Badan Lahir Rendah (BBLR) Pada Ibu Bersalin. *J. Kesehatan*, 1, 1–9.
- Novianti, S. & Aisyah, I. S. (2018). Hubungan Anemia Pada Ibu Hamil Dan Bblr. *J. Siliwangi*, 5, 6–8.
- Olusanya, B. O., & Ofovwe, G. E. (2010). Predictors of preterm births and low birthweight in an inner-city hospital in sub-Saharan Africa. *Maternal*

and *Child Health Journal*, 14(6), 978–986.

- Olusanya BO, O. G. (2010). Predictors of preterm births and low birthweight in an inner-city hospital in sub-Saharan Africa. *Matern Child Health J*, 14(6), 978–86.
- Opintan, J. A., Newman, M. J., Ayeh-Kumi, P. F., Affrim, R., Gepi-Attee, R., Sevilleja, J. E. A. D., Roche, J. K., Nataro, J. P., Warren, C. A., & Guerrant, R. L. (2010). Pediatric diarrhea in southern Ghana: etiology and association with intestinal inflammation and malnutrition. *The American Journal of Tropical Medicine and Hygiene*, 83(4), 936.
- Owino, V., Ahmed, T., Freemark, M., Kelly, P., Loy, A., Manary, M., & Loechl, C. (2016). Environmental enteric dysfunction and growth failure/stunting in global child health. *Pediatrics*, 138(6). <https://doi.org/10.1542/peds.2016-0641>
- Padhi, B. K., Baker, K. K., Dutta, A., Cumming, O., Freeman, M. C., Satpathy, R., Das, B. S., & Panigrahi, P. (2015). Risk of adverse pregnancy outcomes among women practicing poor sanitation in rural India: a population-based prospective cohort study. *PLoS Medicine*, 12(7), e1001851.
- Pitiphat, W., Gillman, M. W., Joshipura, K. J., Williams, P. L., Douglass, C. W., & Rich-Edwards, J. W. (2005). Plasma C-reactive protein in early pregnancy and preterm delivery. *American Journal of Epidemiology*, 162(11), 1108–1113.
- Platts-Mills, J. A., Liu, J., Rogawski, E. T., Kabir, F., Lertsethtakarn, P., Siguas, M., Khan, S. S., Praharaj, I., Murei, A., & Nshama, R. (2018). Use of quantitative molecular diagnostic methods to assess the aetiology, burden, and clinical characteristics of diarrhoea in children in low-resource settings: a reanalysis of the MAL-ED cohort study. *The Lancet Global Health*, 6(12), e1309–e1318.
- Prendergast, A. J., Humphrey, J. H., Mutasa, K., Majo, F. D., Rukobo, S., Govha, M., Mbuya, M. N. N., Moulton, L. H., & Stoltzfus, R. J. (2015). Assessment of environmental enteric dysfunction in the SHINE trial: methods and challenges. *Clinical Infectious Diseases*, 61(suppl_7), S726–S732.
- Prendergast A, K. P. (2012). Enteropathies in the developing world: neglected effects on global health. *Am J Trop Med Hyg*, 86(5), 756–763.
- Prendergast AJ, Rukobo S, Chasekwa B, et al. (2014). Stunting is characterized by chronic inflammation in Zimbabwean infants. *PLoS ONE*, 9(2).
- Purwanto, A. D. (2017). Hubungan Antara Umur Kehamilan, Kehamilan

Ganda, Hipertensi dan Anemia Dengan Kejadian Bayi Berat Lahir Rendah (BBLR). *J. Ilmu. Kedokteran*, 349–359.

- Quigley EMM, Ross IN, Haeney MR, Holbrook IB, M. M. (1987). Reassessment of faecal alpha-1antitrypsin excretion for use as screening test for intestinal protein loss. *J Clin Pathol*.
- Radhakrishna, K. V, Hemalatha, R., Geddam, J. J. B., Kumar, P. A., Balakrishna, N., & Shatrugna, V. (2013). Effectiveness of zinc supplementation to full term normal infants: a community based double blind, randomized, controlled, clinical trial. *PLoS One*, 8(5), e61486.
- Ramakrishnan, U., Grant, F., Goldenberg, T., Zongrone, A., & Martorell, R. (2012). Effect of women's nutrition before and during early pregnancy on maternal and infant outcomes: a systematic review. *Paediatric and Perinatal Epidemiology*, 26, 285–301.
- Rappaport, S. M., Barupal, D. K., Wishart, D., Vineis, P., & Scalbert, A. (2014). The blood exposome and its role in discovering causes of disease. *Environmental Health Perspectives*, 122(8), 769–774.
- Resnik, R. MD., Creasy, R. M. (2010). Intrauterine Growth Restriction Creasy & Resnik's Maternal-Fetal Medicine. *Elsevier Inc*, Chapter 10.
- Rogawski, E. T., Liu, J., Platts-Mills, J. A., Kabir, F., Lertsethtakarn, P., Siguas, M., Khan, S. S., Praharaj, I., Murei, A., & Nshama, R. (2018). Use of quantitative molecular diagnostic methods to investigate the effect of enteropathogen infections on linear growth in children in low-resource settings: longitudinal analysis of results from the MAL-ED cohort study. *The Lancet Global Health*, 6(12), e1319–e1328.
- Ruel, M. T., Alderman, H., & Group, M. and C. N. S. (2013). Nutrition-sensitive interventions and programmes: how can they help to accelerate progress in improving maternal and child nutrition? *The Lancet*, 382(9891), 536–551.
- Sahoo KC, Hulland KR, Caruso BA, Swain R, Freeman MC, Panigrahi P, et al. (2015). Sanitation-related psychosocial stress: A grounded theory study of women across the life-course in Odisha, India. *Soc Sci Med*, 139, 80–9.
- Saifuddin. (2001). *Pelayanan Kesehatan Maternal dan Neonatal*. EGC Jakarta.
- Sebayang, S. K., Dibley, M. J., Kelly, P. J., Shankar, A. V, Shankar, A. H., & Group, S. S. (2012). Determinants of low birthweight, small-for-gestational-age and preterm birth in Lombok, Indonesia: analyses of the birthweight cohort of the SUMMIT trial. *Tropical Medicine & International Health*, 17(8), 938–950.

- Sen, J., Roy, A., & Mondal, N. (2010). Association of maternal nutritional status, body composition and socio-economic variables with low birth weight in India. *Journal of Tropical Pediatrics*, *56*(4), 254–259.
- Shapiro, G. D., Fraser, W. D., Frasch, M. G., & Séguin, J. R. (2013). Psychosocial stress in pregnancy and preterm birth: associations and mechanisms. *Journal of Perinatal Medicine*, *41*(6), 631–645.
- Shapiro GD, Fraser WD, Frasch MG, S. J. (2013). Psychosocial stress in pregnancy and preterm birth: associations and mechanisms. *J Perinat Med*, *41*(6), 631–45.
- Sharma, J. B. & Shankar, M. (2010). Anemia in Pregnancy. *JIMSA*, *4*, 253–260.
- Shinta Mahdalena, Tutik Astuti, & V. (2018). Faktor-Faktor Yang Berhubungan Dengan Kejadian BBLR Di Rsud Wonosari, Gunungkidul Tahun 2017. *J. Kesehat. Masy*, *5*, 406–413.
- Sieczkowska, A., Landowski, P., Kaminska, B., & Lifschitz, C. (2016). Small bowel bacterial overgrowth in children. *Journal of Pediatric Gastroenterology and Nutrition*, *62*(2), 196–207.
- Smith MI, Yatsunenکو T, Manary MJ, et al. (2013). Gut microbiomes of Malawian twin pairs discordant for kwashiorkor. *Science*, *339*, 548.
- Steiner, T. S., Lima, A. A. M., Nataro, J. P., & Guerrant, R. L. (1998). Enteroaggregative *Escherichia coli* produce intestinal inflammation and growth impairment and cause interleukin-8 release from intestinal epithelial cells. *Journal of Infectious Diseases*, *177*(1), 88–96.
- Strygler B, Nicar MJ, Santangelo WC, Porter JL, F. J. (1990). Alpha 1-Antitrypsin excretion in stool in normal subjects and in patients with gastrointestinal disorders. *Gastroenterology*, *99*, 1380-7.
- Sulistiyorini, A. P. dan C. I. (2010). *Berat Badan Bayi Baru Lahir*.
- Supriasa. (2013). *Penilaian Status Gizi*. EGC.Jakarta.
- Syed, S., Ali, A., & Duggan, C. (2016). Environmental Enteric Dysfunction in Children: A Review HHS Public Access. *J Pediatr Gastroenterol Nutr*, *63*(1), 6–14. <https://doi.org/10.1097/MPG.0000000000001147>. Environmental
- Syed, S., & Duggan, C. P. (2016). Risk Factors for Malnutrition and Environmental Enteric Dysfunction—You Really Are What You Eat. *The Journal of Pediatrics*, *178*, 7–8.
- Tang, A. M., Chung, M., Dong, K., Terrin, N., Edmonds, A., Assefa, N., & Maalouf-Manasseh, Z. (2016). Determining a global mid-upper arm circumference cutoff to assess malnutrition in pregnant women. *Food and Nutrition Technical Assistance*, *23*(17), 3104–3113.

- Tangsilsat D, Atamasirikul K, Treepongkaruna S, Nathsevee S, S., & R, K. M. (2007). Fecal Alpha1 - Antitrypsin in Healthy and Intestinal Disorder Thai Children. *J Med Assoc Thai*, 90, 1317-22.
- Thurnham, D. I., Northrop-Clewes, C. A., McCullough, F. S. W., Das, B. S., & Lunn, P. G. (2000). Innate immunity, gut integrity, and vitamin A in Gambian and Indian infants. *The Journal of Infectious Diseases*, 182(Supplement_1), S23–S28.
- Tickell, K. D., Atlas, H. E., & Walson, J. L. (2019). Environmental enteric dysfunction: a review of potential mechanisms, consequences and management strategies. *BMC Medicine*, 17(1), 181. <https://doi.org/10.1186/s12916-019-1417-3>
- Tjoa, M. L., Van Vugt, J. M. G., Go, A., Blankenstein, M. A., Oudejans, C. B. M., & Van Wijk, I. J. (2003). Elevated C-reactive protein levels during first trimester of pregnancy are indicative of preeclampsia and intrauterine growth restriction. *Journal of Reproductive Immunology*, 59(1), 29–37.
- Trehan, I., Kelly, P., Shaikh, N., & Manary, M. J. (2016). New insights into environmental enteric dysfunction. *Archives of Disease in Childhood*, 101(8), 741–744.
- United Nation Children’s Fund (UNICEF) and World Health Organization (WHO). (2004). *Low Birth Weight, Country, Regional and Global Estimates*.
- Ursell LK, Metcalf JL, Parfrey LW, K. R. (2012). Defining the human microbiome. *Nutr Rev*, 38–44.
- van der Merwe, L. F., Moore, S. E., Fulford, A. J., Halliday, K. E., Drammeh, S., Young, S., & Prentice, A. M. (2013). Long-chain PUFA supplementation in rural African infants: a randomized controlled trial of effects on gut integrity, growth, and cognitive development. *The American Journal of Clinical Nutrition*, 97(1), 45–57.
- Vrijheid, M., Slama, R., Robinson, O., Chatzi, L., Coen, M., Van den Hazel, P., Thomsen, C., Wright, J., Athersuch, T. J., & Avellana, N. (2014). The human early-life exposome (HELIX): project rationale and design. *Environmental Health Perspectives*, 122(6), 535–544.
- Wahyu Pujiastuti, S. B. I. (2015). Faktor-Faktor Yang Mempengaruhi Kejadian Bayi Berat Lahir. *Journal of Obstetric, Gynecologic, and Neonatal Nursing : JOGNN / NAACOG*, 7.
- Weizman Z, Binsztok M, Fraser D, Deckelbaum RJ, G. E. (2002). Intestinal Protein Loss in Acute and Persistent Diarrhea of Early Childhood. *J Clin Gastroenterol*, 34, 427-9.
- WHO. (2015). *Angka Kematian Ibu dan Angka Kematian Bayi*.

- WHO. (2016). General assembly proclaims the decade of action on nutrition. *Journal of the Home Economics Institute of Australia*, 23(3), 27–29.
- Wiknjosastro. (2008). *Ilmu Kebidanan*. Nuha Medika. Yogyakarta.
- Wiknjosastro, H. (2014). *Ilmu Kebidanan (Kelima Cet)*. Nuha Medika. Yogyakarta.
- Wilkinson, A. L., Pedersen, S. H., Urassa, M., Michael, D., Andreasen, A., Todd, J., Kinung'hi, S. M., Chagalucha, J., & McDermid, J. M. (2017). Maternal systemic or cord blood inflammation is associated with birth anthropometry in a Tanzanian prospective cohort. *Tropical Medicine & International Health*, 22(1), 52–62.
- Yaqin, K. (2019). *Petunjuk praktis aplikasi biomarker sederhana*. UPT UNHAS PRESS.
- Zhang, L., Nichols, R. G., Correll, J., Murray, I. A., Tanaka, N., Smith, P. B., Hubbard, T. D., Sebastian, A., Albert, I., & Hatzakis, E. (2015). Persistent organic pollutants modify gut microbiota–host metabolic homeostasis in mice through aryl hydrocarbon receptor activation. *Environmental Health Perspectives*, 123(7), 679–688.

Lampiran 1. Formulir Persetujuan Setelah Penjelasan

SURAT PERSETUJUAN

Yang bertanda tangan di bawah ini :

Nama :

Usia :

Setelah mendapatkan keterangan secukupnya, serta menyadari manfaat dari penelitian yang berjudul :

DETERMINAN DISFUNGSI ENTERIK LINGKUNGAN PADA IBU HAMIL TERHADAP BERAT BADAN LAHIR DI RUMAH SAKIT BERSALIN IBU DAN ANAK KARTINI MAKASSAR

dengan sukarela menyetujui diikut sertakan dalam penelitian, dengan catatan bila suatu waktu merasa dirugikan dalam bentuk apapun, berhak membatalkan persetujuan ini dan berhak untuk mengundurkan diri.

Makassar, 2021

Mengetahui,

Yang menyetujui,

Penanggungjawab penelitian

Peserta

()

()

Lampiran 2. Instrumen penelitian**PROGRAM PASCA SARJANA UNIVERSITAS HASANUDDIN****LEMBAR KUESIONER PENELITIAN****DETERMINAN DISFUNGSI ENTERIK LINGKUNGAN PADA IBU HAMIL
TERHADAP BERAT BADAN LAHIR DI RUMAH SAKIT BERSALIN IBU
DAN ANAK KARTINI MAKASSAR**

Nomor :

Responden

Tanggal :

wawancara

Identitas :

Wilayah

Kecamatan :

Kelurahan :

Alamat :

Identitas :

Umum

Nama Ibu :

Umur :

Pendidikan :

Agama :

Pekerjaan Ibu :

Pekerjaan :

Suami

Usia :

Kehamilan

Nomor :

HP/WA

Status Gizi :

(LILA) Ibu

Ukuran LILA : **cm**

Ibu

Pertanyaan :

Tentang Sanitasi

Lingkungan

1. Keadaan

Jamban 1. empang (skor = 0)

Jika buang 2. Jamban/WC (memiliki septic tank) (skor = 1)

air besar

di jamban,

bentuk

jamban

yang

bapak/ibu

gunakan?

2. Jenis lantai

rumah

1. Tanah (skor = 0)

a. Lantai

rumah

2. Plester/keramik
(skor = 1)

bapak/ibu

terbuat

dari apa?

b. Apa jenis

1. Tanah (skor = 0)

lantai

2. Plester/keramik (skor = 1)

kamar

mandi

bapak/ibu

3. Air**a. Air yang****digunakan**

1. sungai (skor = 0)

sehri-hari

2. air sumur gali/air PAM/air sumur (skor = 1)

oleh**bapak/ibu****berasal****dari****mana?****b. Bagaimana** 1. Tidak memenuhi syarat (berbau, berasa dan berwarna) (skor = 0)**kualitas**

2. Memenuhi syarat tidak berbau, ebrasa dan berwarna (skor = 1)

fisik air?

Lampiran 3 : Master Tabel

Alamat	Identitas umum						Identitas Ibu & Bayi				Pertanyaan tentang sanitasi					Biomarker EED
	Inisial	Umur	Agama	Pekerjaan ibu	Pendidikan Ibu	Pekerjaan suami	BBL	Status Gizi (LILA) 28 mgg	Status Gizi (LILA) 32 mgg	Status Gizi (LILA) 36 mgg	Keadaan jamban	Jenis lantai rumah		Air		
											bentuk jamban	Lantai rumah terbuat dari	Lantai kamar mandi terbuat dari	Sumber air	Kualitas fisik air	
B7	La	30	0	IRT	SMP	Supir Ojol	3250	23.2	23.3	23.3	0	0	0	0	0	71,2
ER	Mi	38	1	IRT	SD	Kuli Bangunan	2.100	23.0	23.0	23.0	0	0	0	0	0	109,3
JKP	Az	37	2	IRT	SD	Kuli Bangunan	2200	23.2	23.2	23.4	0	0	0	0	0	192,7
TTK	Ri	30	0	Wiraswasta	SMP	Penjaga Toko	3100	22.8	23.3	23.3	1	0	1	0	0	64,6
CJ	Sa	35	0	Wiraswasta	SMP	Ojol	2900	22.8	22.9	23.0	0	0	1	1	0	90,6
GJ	Re	36	3	IRT	SD	Ojol	2300	22.8	22.8	22.8	1	1	1	1	0	171,3
DK	Li	35	0	Wiraswasta	SMP	Kuli Bangunan	3600	22.0	22.2	22.2	1	0	0	0	0	68,7
DM	Mei	35	0	IRT	SD	Tukang becak	2400	21.4	22.2	22.4	0	0	0	0	0	186,4
DB	Bae	40	0	IRT	SD	Kuli Bangunan	2300	22.6	22.8	23.0	0	0	0	0	0	121,5
PB	Nur	37	0	Karyawan Swasta	SMP	Satpam	3400	21.8	22.1	22.3	0	1	1	0	0	71,3
JBU	Yun	35	0	Karyawan Swasta	SMA	Buruh Harian	2880	23.3	23.3	23.3	0	1	1	1	0	156,5
BP	Nur I	35	0	Karyawan Swasta	SMA	Buruh Harian	2800	22.4	22.6	22.8	1	0	1	0	0	85,7
PBL	NB	39	0	PNS	SMA	Nelayan	3000	22.4	22.4	22.4	0	0	0	0	0	86,9
JIT	NA	35	0	IRT	SMP	Supir Daerah	2180	22.5	22.8	22.8	1	1	1	1	0	139,3
AY	De	37	0	IRT	SMP	Tukang becak	2100	22.1	22.1	22.3	0	0	1	0	0	107,9
JTL		36	0	PNS	SMA	Supir Daerah	2700	23.3	23.3	23.4	1	1	1	0	0	77,9
JMM	Il	41	0	IRT	SMA	Buruh Harian	2600	22.9	22.9	23.1	0	0	0	0	0	65,7
LE	Ir	42	0	IRT	SMA	Satpam	3000	22.9	23.0	23.0	1	1	1	1	0	87,4

Alamat	Identitas umum						Identitas Ibu & Bayi				Pertanyaan tentang sanitasi					Biomarker EED	
	Inisial	Umur	Agama	Pekerjaan ibu	Pendidikan Ibu	Pekerjaan suami	BBL	Status Gizi (LILA) 28 mgg	Status Gizi (LILA) 32 mgg	Status Gizi (LILA) 36 mgg	Keadaan jamban		Jenis lantai rumah		Air		
											bentuk jamban	Lantai rumah terbuat dari	Lantai kamar mandi terbuat dari	Sumber air	Kualitas fisik air		
REA	Mur	43	0	IRT	SMA	Penjaga Toko	3000	22.3	22.3	22.3	1	0	1	0	0	77,6	
MAN	NH	45	0	IRT	SMA	Supir Daerah	3100	22.5	22.6	23.0	0	0	0	0	0	58,4	
BBG	SO	35	0	IRT	SMA	Ojol	2800	22.9	22.9	22.9	1	0	0	1	0	196,2	
TTK	Rita	45	0	IRT	SMA	Buruh Harian	2800	22.8	22.8	22.8	0	0	0	0	0	74,5	
JMN	FA	35	0	IRT	SMA	Buruh Harian	2000	22.3	22.6	22.8	0	0	0	0	0	126,9	
BTT	HA	40	0	IRT	SMA	Tukang becak	2600	23.3	23.3	23.3	1	1	1	1	0	93,2	
JDK	L	37	0	IRT	SMA	Buruh Harian	3000	23.3	23.3	23.4	0	0	1	0	0	70,3	
JRT	AG	42	0	IRT	SMA	Penjaga Toko	3100	22.4	22.6	23.1	1	0	1	0	0	83,6	
BT	RR	45	0	IRT	SMP	Tukang becak	2000	22.4	22.4	22.4	1	0	1	0	0	137,8	
JB	LY	43	0	IRT	SMA	Tukang sayur	2900	21.4	21.6	22.1	0	0	0	0	0	61,2	
TM	HT	40	0	IRT	SMA	Penjaga Toko	3200	21.4	21.4	21.4	1	0	1	0	0	85,1	
JIT	MN	41	0	IRT	SMA	Ojol	2900	22.5	22.6	22.8	0	0	0	1	0	92,1	
JTD	IA	46	0	IRT	SMA	Buruh Harian	2800	22.0	22.2	22.3	1	0	1	1	0	197,4	
JLM	HH	46	0	IRT	SMA	Buruh Harian	2880	22.1	22.5	22.9	0	0	0	0	0	69,8	
TTK	RK	40	0	IRT	SMA	Buruh Harian	2790	22.2	22.4	22.9	1	0	1	0	0	97,9	
JCJ	ZH	47	0	IRT	SMA	Tukang becak	2700	22.2	22.2	22.2	0	0	0	0	0	99,1	
PPB	AN	30	0	IRT	SMA	Penjaga Toko	2800	23.4	23.4	23.4	1	0	1	1	0	92,7	
JT	Mur	20	0	IRT	SMA	Tukang sayur	3000	23.2	23.4	23.4	1	0	1	1	0	72,8	
JK	RI	46	0	IRT	SD	Tukang Sayur	2200	21.4	21.6	22.3	0	0	0	0	0	125,7	
JN	Re	34	0	IRT	SMP	Penjual Ikan	2100	22.1	22.5	22.8	1	1	1	1	0	134,8	
JTD	AS	45	0	IRT	SMA	Buruh Harian	2300	23.0	23.2	23.3	1	0	1	0	0	127,8	
BB	LM	30	0	IRT	SMA	Penjual Ikan	3200	23.2	23.2	23.2	0	0	1	0	0	178,9	
JMB	Jun	31	0	IRT	SMA	Ojek	3600	23.0	23.2	23.2	1	0	0	0	0	197,1	
JBB	MS	40	0	IRT	D3	Penjual Ikan	2900	23.1	23.1	23.1	0	0	0	0	0	189,3	
JT	Mus	33	0	IRT	S1	Tukang sayur	2800	23.0	23.0	23.2	0	0	0	0	0	172,9	
JTD	AS	41	0	IRT	S1	Buruh Harian	2600	22.8	22.9	23.2	0	0	0	0	0	57,8	
JM	ND	24	1	Wiraswasta	SMP	Pegawai Swasta	3400	23.5	24.5	25.5	0	1	1	1	1	167,8	
JMR	SH	29	1	Wiraswasta	SMP	Pegawai Swasta	3300	23.8	24.1	24.8	1	0	1	1	1	62,3	
JG	LE	30	2	Wiraswasta	SMP	Karyawan Swasta	3600	25.6	25.9	26.9	0	1	1	1	1	193,2	
JBD	BT	26	0	Wiraswasta	SMP	Pegawai Bank	2900	23.9	24.5	25.9	1	0	1	1	1	67,3	
CDI	DI	24	0	Wiraswasta	SMA	Pegawai Swasta	2700	24.4	24.7	25.4	0	1	1	1	1	50,6	

Alamat	Identitas umum						Identitas Ibu & Bayi				Pertanyaan tentang sanitasi					Biomarker EED
	Inisial	Umur	Agama	Pekerjaan ibu	Pendidikan Ibu	Pekerjaan suami	BBL	Status Gizi (LILA) 28 mgg	Status Gizi (LILA) 32 mgg	Status Gizi (LILA) 36 mgg	Keadaan jamban	Jenis lantai rumah		Air		
											bentuk jamban	Lantai rumah terbuat dari	Lantai kamar mandi terbuat dari	Sumber air	Kualitas fisik air	
CBJ	BJ	21	0	Wiraswasta	SMA	Pegawai BUMN	2700	24.1	24.7	25.1	0	1	1	1	1	58,6
JLA	H	23	0	Karyawan Swasta	SMP	Pegawai Swasta	2700	23.7	24.2	24.7	0	1	1	1	1	79,1
PDA	MS	27	0	Karyawan Swasta	SMP	Pegawai Swasta	3000	24.2	24.8	25.2	1	0	1	1	1	81,4
PCC	NF	27	0	Karyawan Swasta	SMA	Pegawai Swasta	2800	24.7	25.2	25.7	0	1	1	1	1	97,2
JSB	Mul	28	0	Karyawan Swasta	SMA	Karyawan Swasta	3200	25.2	25.7	26.2	1	0	1	1	1	93,7
JRR	NAS	23	0	Karyawan Swasta	SMP	Karyawan Swasta	3900	24.1	24.9	25.1	0	1	1	1	1	72,1
BGM	FA	27	0	Karyawan Swasta	SMA	Karyawan Swasta	2900	24.5	24.5	24.9	1	1	1	1	1	75,8
JTD	IA	29	0	Karyawan Swasta	SMP	Pegawai Swasta	2900	24.5	24.9	24.9	1	0	1	1	1	63,6
PSG	RO	26	0	Karyawan Swasta	D3	Perawat	2700	24.3	24.7	24.9	0	0	1	1	1	87,1
JOG	Nsl	28	0	IRT	SMP	Pemilik Toko	3800	24.6	24.6	24.6	1	1	1	1	1	75,2
TDS	RN	27	0	Wiraswasta	SMA	Wiraswasta	3000	24.5	24.7	25.5	1	1	1	1	1	58,6
BOA	Su	36	0	IRT	SD	Pegawai Bank	2400	24.5	25.1	25.5	0	1	1	1	1	182,2
AMD	HL	23	0	Karyawan Swasta	SMP	BUMN	3300	23.9	24.3	24.9	1	1	1	1	1	93,5
MAG	I	29	0	IRT	D3	Pemilik Toko	2900	24.3	24.6	24.8	0	1	1	1	1	70,8
JAK	FAT	35	0	PNS	SD	Pegawai Swasta	2700	24.6	24.9	25.1	1	1	1	1	1	73,2
LPK	NUR	27	0	IRT	SMP	Pegawai Swasta	3100	24.2	24.4	24.4	0	1	1	1	1	92,7
GM	Adr	29	0	IRT	D3	Pegawai Swasta	2800	24.2	24.7	24.9	1	1	1	1	1	65,3
JUP	AW	26	0	IRT	S1	Pegawai Swasta	3100	25.4	25.4	25.4	1	1	1	1	1	89,4
JP	Mut	26	0	Karyawan Swasta	SD	Pemilik Toko	2370	24.1	24.7	25.1	1	1	1	1	1	289,1
BON	SA	29	0	IRT	SMP	Penjaga Toko	3300	25.2	25.6	26.2	1	1	1	1	1	75,3
JL	NU	20	0	IRT	S1	Ojek	2900	23.9	24.9	25.9	1	1	1	1	1	85,1
JRR	NASI	23	0	IRT	SMA	Karyawan Swasta	2600	24.3	25.3	26.3	0	1	1	1	1	91,5
ERA	Mif	20	0	PNS	S1	Pegawai Swasta	2700	23.5	23.7	24.5	1	1	1	1	1	194,2
REA	Her	29	0	PNS	SMA	Pegawai Swasta	2800	24.2	24.9	25.2	1	0	1	1	1	74,9
DJDT	RIS	23	0	PNS	SMA	Pegawai Swasta	2700	24.2	24.4	24.6	1	1	1	1	1	91,2
SAM	Hae	25	0	IRT	S1	Pegawai Swasta	2900	24.4	24.4	24.8	0	1	1	1	1	83,5
JIDK	Tri	30	0	IRT	SMA	Pegawai Swasta	4000	24.7	25.7	26.7	1	1	1	1	1	75,2
ATP	RM	25	0	PNS	S1	Wiraswasta	3000	28.5	29.5	30.2	1	1	1	1	1	82,7
BBR	RW	28	0	IRT	SMA	Pegawai Swasta	4100	26.5	28.5	29.7	1	1	1	1	1	68,4
KKD	DRP	26	0	PNS	SMA	Pegawai Swasta	3350	26.4	26.7	27.4	1	1	1	1	1	69,3

Alamat	Identitas umum						Identitas Ibu & Bayi				Pertanyaan tentang sanitasi					Biomarker EED
	Inisial	Umur	Agama	Pekerjaan ibu	Pendidikan Ibu	Pekerjaan suami	BBL	Status Gizi (LILA) 28 mgg	Status Gizi (LILA) 32 mgg	Status Gizi (LILA) 36 mgg	Keadaan jamban	Jenis lantai rumah		Air		
											bentuk jamban	Lantai rumah terbuat dari	Lantai kamar mandi terbuat dari	Sumber air	Kualitas fisik air	
IKG	NH	24	0	Karyawan Swasta	SMA	Pegawai Swasta	2950	23.8	24.8	25.6	1	1	1	1	1	63,2
JTB	AMS	29	0	PNS	SMA	Pegawai Swasta	3450	24.5	24.9	26.5	1	1	1	1	1	68,9
JIL	LM	31	0	IRT	SMA	Karyawan Swasta	3400	25.7	26.3	26.7	1	1	1	1	1	57,8
JTD	JVK	35	0	IRT	SMA	Pegawai Swasta	4850	27.3	28.3	29.5	0	1	1	1	1	83,3
PBL	NHM	33	0	IRT	SMA	Karyawan Swasta	3150	26.5	27.5	28.3	1	1	1	1	1	64,1
ASP	SRM	36	0	IRT	SMA	Pegawai Swasta	3700	26.4	26.7	26.9	1	1	1	1	1	81,3
ASP	ML	27	0	IRT	SMA	Karyawan Swasta	3500	27.1	28.1	30.1	1	1	1	1	1	70,9
JTN	JVK	30	0	IRT	SMA	Pegawai Swasta	3550	27.5	29.5	30.8	1	1	1	1	1	54,1
PBL	MNH	32	0	IRT	SMA	Karyawan Swasta	3350	27.7	28.4	29.3	1	1	1	1	1	71,8
JAS	SRM	29	0	Karyawan Swasta	SMA	Pegawai Swasta	2950	26.9	27.2	29.9	1	1	1	1	1	81,4

Lampiran 4. Rekomendasi Penelitian Etik



KEMENTERIAN PENDIDIKAN, KEBUDAYAAN
RISET, DAN TEKNOLOGI
UNIVERSITAS HASANUDDIN
FAKULTAS KESEHATAN MASYARAKAT
Jln. Perintis Kemerdekaan Km. 10 Makassar 90245, Telp. (0411) 585658,
E-mail : fkrm.unhas@gmail.com, website: <https://fkrm.unhas.ac.id/>

REKOMENDASI PERSETUJUAN ETIK

Nomor : 9007/UN4.14.1/1P.01.02/2021

Tanggal : 7 Oktober 2021

Dengan ini Menyatakan bahwa Protokol dan Dokumen yang Berhubungan dengan Protokol berikut ini telah mendapatkan Persetujuan Etik :

No.Protokol	23821093017	No. Sponsor Protokol	
Peneliti Utama	Asriana Abdullah	Sponsor	Pribadi
Judul Peneliti	Determinan Disfungsi Enterik Lingkungan Pada Ibu Hamil Terhadap Berat Badan Lahir Di Makassar		
No.Versi Protokol	1	Tanggal Versi	23 Agustus 2021
No.Versi PSP	1	Tanggal Versi	23 Agustus 2021
Tempat Penelitian	Kota Makassar		
Judul Review	<input type="checkbox"/> Exempted <input type="checkbox"/> Expedited <input checked="" type="checkbox"/> Fullboard	Masa Berlaku 7 Oktober 2021 Sampai 7 Oktober 2022	Frekuensi review lanjutan
Ketua Komisi Etik Penelitian	Nama : Prof.dr.Veni Hadju,M.Sc,Ph.D	Tanda tangan 	Tanggal
Sekretaris komisi Etik Penelitian	Nama : Dr. Wahiduddin, SKM.,M.Kes	Tanda tangan 	Tanggal 7 Oktober 2021

Kewajiban Peneliti Utama :

1. Menyerahkan Amandemen Protokol untuk persetujuan sebelum di implementasikan
2. Menyerahkan Laporan SAE ke Komisi Etik dalam 24 Jam dan dilengkapi dalam 7 hari dan Laporan SUSAR dalam 72 Jam setelah Peneliti Utama menerima laporan
3. Menyerahkan Laporan Kemajuan (progress report) setiap 6 bulan untuk penelitian resiko tinggi dan setiap setahun untuk penelitian resiko rendah
4. Menyerahkan laporan akhir setelah Penelitian berakhir
5. Melaporkan penyimpangan dari protocol yang disetujui (protocol deviation/violation)
6. Mematuhi semua peraturan yang ditentukan



Lampiran 5. Izin Penelitian



SURAT KETERANGAN
Nomor : 214/S.Ket/RSIAK/IX/2021

Yang bertanda tangan di bawah ini :

Nama : Dr.dr.Rina Previana Amiruddin Sp.OG (K)

Jabatan : Direktur RSIA Kartini Makassar

Menerangkan dengan Benar Bahwa :

Nama : Asriana Abdullah

NIM : K013181012

Pekerjaan : Mahasiswa Pasca Sarjana UNHAS Makassar Program Studi Kesehatan Masyarakat

Judul Tesis : Determinasi Disfungsi Enterik Lingkungan Pada Ibu Hamil Terhadap Berat Badan Lahir Di Makassar

Telah melakukan penelitian di Rumah Sakit Ibu dan Anak Kartini Makassar sejak 03 Juli 2021 s/d 30 September 2021

Demikian surat keterangan ini di buat untuk digunakan seperlunya

Makassar 06 Oktober 2021

Direktur RSIA Kartini



Dr. dr Rina Previana Amiruddin Sp. OG (K)
 rumah KARTINI

 RUMAH SAKIT UNHAS	SURAT IZIN PENELITIAN	
	Nomor: 10361/UN4.24.1/PT.01.04/2021	Tanggal 21 Oktober 2021
FORMULIR 2 BIDANG PENELITIAN DAN INOVASI	Kepada Yth Kepala Ruang Laboratorium Penelitian	
<p>Dengan hormat,</p> <p>Dengan ini menerangkan bahwa peneliti/ mahasiswa berikut ini:</p> <p>Nama : Asriana Abdullah</p> <p>NIM / NIP : K013181012</p> <p>Institusi : S3 Ilmu Kesehatan Masyarakat, Fakultas Kesehatan Masyarakat , Universitas Hasanuddin Makassar</p> <p>Kode penelitian : 211021_1</p> <p>Akan melakukan pengambilan data/ analisa bahan hayati:</p> <p>Terhitung : 21 Oktober 2021 s/d 31 Oktober 2021</p> <p>Jumlah Subjek/Sample : 88</p> <p>Jenis Data : Data Primer: Elisa</p> <p>Untuk penelitian dengan judul:</p> <p>"Determinan Disfungsi Enterik Lingkungan Pada Ibu Hamil terhadap Berat Badan Lahir Di Makassar"</p> <p>Harap dilakukan pembimbingan dan pendampingan seperlunya.</p> <p>Direktur Pendidikan, Pelatihan dan Penelitian</p> <p> Dr. dr. S. Malsur/ Tadjuddin Chalid, Sp. OG (K) NIP. 196704091996012001</p> <p><i>Catatan: Lembaran ini diarsipkan oleh Bidang Penelitian dan Inovasi</i></p>		

Lampiran 6. Antigen

ID : 211021 - 1



Klinik Lacasino

Mitra Kesehatan Keluarga Anda

Jl. Adyaksa Baru No 45, Masale, Kec. Panakukkang, Kota Makassar, Sulawesi Selatan 90231
Telp. (0411) 456413, Email. kliniklacasinomks@gmail.com

No. Lab	:4117 /KL/MKS/X/2021	Jenis Kelamin	: Perempuan
Nama Pasien	: Asriana Abdullah,S.Si.,M.Kes	Alamat	: Jl Paccinang Raya 2 Komp Kejaksanaan No 36 A
Tanggal Lahir	: 7 Agustus 1984	No. Telepon	: -

HASIL PEMERIKSAAN LABORATORIUM

Jenis Pemeriksaan	Hasil	Rujukan
Immunologi		
Antigen SARS-CoV-2	<i>Negatif</i>	Negatif

Saran :

- Pemeriksaan konfirmasi dengan pemeriksaan RT-PCR
- Lakukan karantina atau isolasi sesuai dengan kriteria
- Menerapkan PHBS (perilaku hidup bersih dan sehat: mencuci tangan , menerapkan etika batuk, menggunakan masker , menjaga stamina), dan physical distancing.

Makassar, 18 Oktober 2021

Dokter Penanggung Jawab
Laboratorium Klinik Lacasino

dr. Hj. Darnawaty Rauf, Sp. PK(K)

Lampiran 7. Keterangan selesai penelitian



KEMENTERIAN PENDIDIKAN, KEBUDAYAAN,
RISET, DAN TEKNOLOGI
UNIVERSITAS HASANUDDIN
RUMAH SAKIT UNHAS

Jl. Perintis Kemerdekaan Km. 10 Tamalanrea, Makassar 90245

Website: www.rs.unhas.ac.id Email: info@rs.unhas.ac.id Telp: (0411) 591331 Fax: (0411) 591332

Nomor : 10508/UN4.24.1/PT.01.05/2021 27 Oktober 2021
Hal : **Surat Keterangan Selesai Penelitian**

Dengan ini menerangkan bahwa mahasiswa yang beridentitas :

Nama : Asriana Abdullah
NIM : K013181012
Institusi : Universitas Hasanuddin Makassar
Kode Penelitian : 211021_1

Telah menyelesaikan penelitian di Rumah Sakit Unhas.

Terhitung pada tanggal : 25 Oktober 2021

Dengan Sampel : Feses Ibu Hamil menggunakan uji Elisa di Laboratorium
Penelitian Rumah Sakit Unhas.

Dalam rangka penyusunan Disertasi yang berjudul:

"Determinan Disfungsi Enterik Lingkungan Pada Ibu Hamil terhadap Berat Badan Lahir Di Makassar"

Demikian surat keterangan ini dibuat dan diberikan kepada yang bersangkutan untuk dipergunakan seperlunya.

Direktur Pendidikan, Pelatihan dan Penelitian



Dr.dr.St.Maisuri Tadjuddin Chalid,Sp.OG (K)
NIR. 196704091996012001

Lampiran 8. ID Peneliti

<p>S3 Ilmu Kesehatan Masyarakat Universitas Hasanuddin Makassar</p> <p>KARTU TANDA PENGENAL HANYA DIGUNAKAN SELAMA BERADA DI RS UNHAS</p> <p>JIKA KARTU INI TERCECER/ ATAU JIKA PEMILIK KARTU BERMASALAH HUBUNGI STAF PENELITIAN (WADDAH) 085299919103</p>	<p> RUMAH SAKIT UNHAS</p> <hr/> <p>Asriana Abdullah</p> <p></p> <p>ID Peneliti : 211021_1</p> <p>PENELITIAN BERLAKU SAMPAI 31 OKTOBER 2021</p>
-----------------------------------------------------------------------------------------------------------------------------------------------------------------------------------------------------------------------------------------------------------------------------------------------------------------------------	--------------------------------------------------------------------------------------------------------------------------------------------------------------------------------------------------------------------------------------------------------------------------------------------------------------------------------------------------------

Lampiran 8. Output SPSS

Crosstabs

Case Processing Summary

	Cases					
	Valid		Missing		Total	
	N	Percent	N	Percent	N	Percent
KatAAT * Kelompok * Klmpok_umur	88	100.0%	0	0.0%	88	100.0%

KatAAT * Kelompok * Klmpok_umur Crosstabulation

Klmpok_umur				Kelompok		Total
				Terpapar	Tidak terpapar	
<20 tahun	KatAAT	Tidak EED	Count	1	2	3
			% within KatAAT	33.3%	66.7%	100.0%
	Total		Count	1	2	3
			% within KatAAT	33.3%	66.7%	100.0%
20-35 tahun	KatAAT	EED	Count	4	1	5
			% within KatAAT	80.0%	20.0%	100.0%
	Tidak EED	Count	11	39	50	
		% within KatAAT	22.0%	78.0%	100.0%	
	Total		Count	15	40	55
		% within KatAAT	27.3%	72.7%	100.0%	
>35 tahun	KatAAT	EED	Count	11	1	12
			% within KatAAT	91.7%	8.3%	100.0%
	Tidak EED	Count	17	1	18	
		% within KatAAT	94.4%	5.6%	100.0%	
	Total		Count	28	2	30
		% within KatAAT	93.3%	6.7%	100.0%	
Total	KatAAT	EED	Count	15	2	17
			% within KatAAT	88.2%	11.8%	100.0%
	Tidak EED	Count	29	42	71	
		% within KatAAT	40.8%	59.2%	100.0%	
	Total		Count	44	44	88
		% within KatAAT	50.0%	50.0%	100.0%	

Crosstabs

Case Processing Summary

	Cases					
	Valid		Missing		Total	
	N	Percent	N	Percent	N	Percent
KatAAT * Kelompok * Pendidikan	88	100.0%	0	0.0%	88	100.0%

KatAAT * Kelompok * Pendidikan Crosstabulation

Pendidikan				Kelompok		Total
				Terpapar	Tidak terpapar	
SD	KatAAT	EED	Count	5	2	7
			% within KatAAT	71.4%	28.6%	100.0%
	Tidak EED	Count	1	1	2	
		% within KatAAT	50.0%	50.0%	100.0%	
Total		Count	6	3	9	
		% within KatAAT	66.7%	33.3%	100.0%	
SMP	KatAAT	EED	Count	4	0	4
			% within KatAAT	100.0%	0.0%	100.0%
	Tidak EED	Count	5	12	17	
		% within KatAAT	29.4%	70.6%	100.0%	
Total		Count	9	12	21	
		% within KatAAT	42.9%	57.1%	100.0%	
SMA	KatAAT	EED	Count	6	0	6
			% within KatAAT	100.0%	0.0%	100.0%
	Tidak EED	Count	20	21	41	
		% within KatAAT	48.8%	51.2%	100.0%	
Total		Count	26	21	47	
		% within KatAAT	55.3%	44.7%	100.0%	
Akademi	KatAAT	Tidak EED	Count	1	3	4
			% within KatAAT	25.0%	75.0%	100.0%
	Total		Count	1	3	4
		% within KatAAT	25.0%	75.0%	100.0%	
Sarjana	KatAAT	Tidak EED	Count	2	5	7
			% within KatAAT	28.6%	71.4%	100.0%
	Total		Count	2	5	7
		% within KatAAT	28.6%	71.4%	100.0%	
Total	KatAAT	EED	Count	15	2	17
			% within KatAAT	88.2%	11.8%	100.0%
	Tidak EED	Count	29	42	71	
		% within KatAAT	40.8%	59.2%	100.0%	
Total		Count	44	44	88	
		% within KatAAT	50.0%	50.0%	100.0%	

Crosstabs

Case Processing Summary

	Cases					
	Valid		Missing		Total	
	N	Percent	N	Percent	N	Percent
KatAAT * Kelompok * Agama	88	100.0%	0	0.0%	88	100.0%

KatAAT * Kelompok * Agama Crosstabulation

Agama				Kelompok		Total
				Terpapar	Tidak terpapar	
Islam	KatAAT	EED	Count	13	2	15
			% within KatAAT	86.7%	13.3%	100.0%
	Tidak EED	Count	28	39	67	
		% within KatAAT	41.8%	58.2%	100.0%	
	Total	Count	41	41	82	
		% within KatAAT	50.0%	50.0%	100.0%	
Kristen protestan	KatAAT	EED	Count	1	0	1
			% within KatAAT	100.0%	0.0%	100.0%
	Tidak EED	Count	0	2	2	
		% within KatAAT	0.0%	100.0%	100.0%	
	Total	Count	1	2	3	
		% within KatAAT	33.3%	66.7%	100.0%	
Kristen katolik	KatAAT	EED	Count	1	0	1
			% within KatAAT	100.0%	0.0%	100.0%
	Tidak EED	Count	0	1	1	
		% within KatAAT	0.0%	100.0%	100.0%	
	Total	Count	1	1	2	
		% within KatAAT	50.0%	50.0%	100.0%	
Hindu	KatAAT	Tidak EED	Count	1		1
			% within KatAAT	100.0%		100.0%
	Total	Count	1		1	
		% within KatAAT	100.0%		100.0%	
Total	KatAAT	EED	Count	15	2	17
			% within KatAAT	88.2%	11.8%	100.0%
	Tidak EED	Count	29	42	71	
		% within KatAAT	40.8%	59.2%	100.0%	
	Total	Count	44	44	88	
		% within KatAAT	50.0%	50.0%	100.0%	

Crosstabs

Case Processing Summary

	Cases					
	Valid		Missing		Total	
	N	Percent	N	Percent	N	Percent
KatAAT * Kelompok * Pekerjaan ibu	88	100.0%	0	0.0%	88	100.0%

KatAAT * Kelompok * Pekerjaan ibu Crosstabulation

Pekerjaan ibu				Kelompok		Total
				Terpapar	Tidak terpapar	
IRT	KatAAT	EED	Count	15	1	16
			% within KatAAT	93.8%	6.3%	100.0%
	Tidak EED	Count	21	18	39	
		% within KatAAT	53.8%	46.2%	100.0%	
Total			Count	36	19	55
			% within KatAAT	65.5%	34.5%	100.0%
PNS/Karyawan/Wir aswasta	KatAAT	EED	Count	0	1	1
			% within KatAAT	0.0%	100.0%	100.0%
	Tidak EED	Count	8	24	32	
		% within KatAAT	25.0%	75.0%	100.0%	
Total			Count	8	25	33
			% within KatAAT	24.2%	75.8%	100.0%
Total	KatAAT	EED	Count	15	2	17
			% within KatAAT	88.2%	11.8%	100.0%
	Tidak EED	Count	29	42	71	
		% within KatAAT	40.8%	59.2%	100.0%	
Total			Count	44	44	88
			% within KatAAT	50.0%	50.0%	100.0%

Crosstabs

Case Processing Summary

	Cases					
	Valid		Missing		Total	
	N	Percent	N	Percent	N	Percent
KatAAT * Kelompok * Pekerjaan suami	88	100.0%	0	0.0%	88	100.0%

KatAAT * Kelompok * Pekerjaan suami Crosstabulation

				Kelompok		Total
				Terpapar	Tidak terpapar	
Pekerjaan suami						
Karyawan	KatAAT	EED	Count	5	1	6
			% within KatAAT	83.3%	16.7%	100.0%
		Tidak EED	Count	13	37	50
			% within KatAAT	26.0%	74.0%	100.0%
	Total		Count	18	38	56
			% within KatAAT	32.1%	67.9%	100.0%
Wiraswasta/Pedagang	KatAAT	EED	Count	1	1	2
			% within KatAAT	50.0%	50.0%	100.0%
		Tidak EED	Count	3	4	7
			% within KatAAT	42.9%	57.1%	100.0%
	Total		Count	4	5	9
			% within KatAAT	44.4%	55.6%	100.0%
(Kuli bangunan, tukang becak, tukang ojek, tukang sayur, supir)	KatAAT	EED	Count	9	0	9
			% within KatAAT	100.0%	0.0%	100.0%
		Tidak EED	Count	13	1	14
			% within KatAAT	92.9%	7.1%	100.0%
	Total		Count	22	1	23
			% within KatAAT	95.7%	4.3%	100.0%
Total	KatAAT	EED	Count	15	2	17
			% within KatAAT	88.2%	11.8%	100.0%
		Tidak EED	Count	29	42	71
			% within KatAAT	40.8%	59.2%	100.0%
	Total		Count	44	44	88
			% within KatAAT	50.0%	50.0%	100.0%

Explore

Kelompok

Case Processing Summary

	Kelompok	Cases					
		Valid		Missing		Total	
		N	Percent	N	Percent	N	Percent
LILA28	Terpapar	44	100.0%	0	0.0%	44	100.0%
	Tidak terpapar	44	100.0%	0	0.0%	44	100.0%
Total_Sanitasi	Terpapar	44	100.0%	0	0.0%	44	100.0%
	Tidak terpapar	44	100.0%	0	0.0%	44	100.0%
AAT	Terpapar	44	100.0%	0	0.0%	44	100.0%
	Tidak terpapar	44	100.0%	0	0.0%	44	100.0%
BBLRASIO	Terpapar	44	100.0%	0	0.0%	44	100.0%
	Tidak terpapar	44	100.0%	0	0.0%	44	100.0%

Descriptives

Kelompok		Statistic	Std. Error		
LILA28	Terpapar	Mean	22.582	.0859	
		95% Confidence Interval for Mean	Lower Bound 22.409	Upper Bound 22.755	
		5% Trimmed Mean	22.605		
		Median	22.700		
		Variance	.324		
		Std. Deviation	.5695		
		Minimum	21.4		
		Maximum	23.4		
		Range	2.0		
		Interquartile Range	.8		
		Skewness	-.585	.357	
		Kurtosis	-.435	.702	
		Tidak terpapar	Mean	24.991	.1931
			95% Confidence Interval for Mean	Lower Bound 24.602	Upper Bound 25.380
	5% Trimmed Mean		24.903		
	Median		24.500		
	Variance		1.640		
	Std. Deviation		1.2806		
	Minimum		23.5		
	Maximum		28.5		
	Range		5.0		
	Interquartile Range		1.6		
Total_Sanitasi	Terpapar	Mean	1.32	.183	
		95% Confidence Interval for Mean	Lower Bound .95	Upper Bound 1.69	
		5% Trimmed Mean	1.30		
		Median	1.00		
		Variance	1.478		
		Std. Deviation	1.216		
		Minimum	0		
		Maximum	3		
		Range	3		
		Interquartile Range	2		
		Skewness	.162	.357	
		Kurtosis	-1.583	.702	
		Tidak terpapar	Mean	4.57	.076
			95% Confidence Interval for Mean	Lower Bound 4.42	Upper Bound 4.72
	5% Trimmed Mean		4.58		
	Median		5.00		
	Variance		.251		
	Std. Deviation		.501		
	Minimum		4		

		Maximum	5	
		Range	1	
		Interquartile Range	1	
		Skewness	-.285	.357
		Kurtosis	-2.012	.702
AAT	Terpapar	Mean	102.86	6.240
		95% Confidence Interval for Mean	Lower Bound 90.28 Upper Bound 115.44	
		5% Trimmed Mean	100.15	
		Median	88.35	
		Variance	1713.157	
		Std. Deviation	41.390	
		Minimum	57	
		Maximum	198	
		Range	141	
		Interquartile Range	55	
		Skewness	1.172	.357
		Kurtosis	.363	.702
	Tidak terpapar	Mean	83.58	5.623
		95% Confidence Interval for Mean	Lower Bound 72.24 Upper Bound 94.91	
		5% Trimmed Mean	77.35	
		Median	75.25	
		Variance	1391.118	
		Std. Deviation	37.298	
		Minimum	54	
		Maximum	289	
		Range	235	
		Interquartile Range	21	
		Skewness	4.464	.357
		Kurtosis	22.785	.702
BBLRASIO	Terpapar	Mean	2747.27	62.824
		95% Confidence Interval for Mean	Lower Bound 2620.58 Upper Bound 2873.97	
		5% Trimmed Mean	2741.92	
		Median	2800.00	
		Variance	173662.15 6	
		Std. Deviation	416.728	
		Minimum	2000	
		Maximum	3600	
		Range	1600	
		Interquartile Range	675	
		Skewness	-.140	.357
		Kurtosis	-.538	.702
	Tidak terpapar	Mean	3151.59	73.553
		95% Confidence Interval for Mean	Lower Bound 3003.26 Upper Bound 3299.92	
		5% Trimmed Mean	3121.97	
		Median	3000.00	

Variance	238041.596	
Std. Deviation	487.895	
Minimum	2370	
Maximum	4850	
Range	2480	
Interquartile Range	600	
Skewness	1.180	.357
Kurtosis	2.177	.702

Tests of Normality

	Kelompok	Kolmogorov-Smirnov ^a			Shapiro-Wilk		
		Statistic	df	Sig.	Statistic	df	Sig.
LILA28	Terpapar	.149	44	.015	.932	44	.012
	Tidak terpapar	.249	44	.000	.852	44	.000
Total_Sanitasi	Terpapar	.247	44	.000	.812	44	.000
	Tidak terpapar	.374	44	.000	.630	44	.000
AAT	Terpapar	.195	44	.000	.845	44	.000
	Tidak terpapar	.320	44	.000	.497	44	.000
BBLRASIO	Terpapar	.154	44	.010	.953	44	.070
	Tidak terpapar	.145	44	.021	.923	44	.006

a. Lilliefors Significance Correction

Test of Homogeneity of Variance

		Levene Statistic	df1	df2	Sig.
LILA28	Based on Mean	23.619	1	86	.000
	Based on Median	7.701	1	86	.007
	Based on Median and with adjusted df	7.701	1	52.129	.008
	Based on trimmed mean	19.285	1	86	.000
Total_Sanitasi	Based on Mean	71.591	1	86	.000
	Based on Median	31.095	1	86	.000
	Based on Median and with adjusted df	31.095	1	83.209	.000
	Based on trimmed mean	70.528	1	86	.000
AAT	Based on Mean	5.966	1	86	.017
	Based on Median	3.687	1	86	.058
	Based on Median and with adjusted df	3.687	1	85.420	.058
	Based on trimmed mean	5.686	1	86	.019
BBLRASIO	Based on Mean	.596	1	86	.442
	Based on Median	.462	1	86	.499

Based on Median and with adjusted df	.462	1	80.033	.499
Based on trimmed mean	.454	1	86	.502

Frequencies

Statistics

Total_Sanitasi

N	Valid	88
	Missing	0
Mean		2.94
Median		3.50
Std. Deviation		1.878
Minimum		0
Maximum		5

Crosstabs

Case Processing Summary

	Cases					
	Valid		Missing		Total	
	N	Percent	N	Percent	N	Percent
bentuk jamban *	88	100.0%	0	0.0%	88	100.0%
Kelompok Lantai rumah terbuat dari *	88	100.0%	0	0.0%	88	100.0%
Kelompok Lantai kamar mandi terbuat dari * Kelompok	88	100.0%	0	0.0%	88	100.0%
Sumber air *	88	100.0%	0	0.0%	88	100.0%
Kelompok Kualitas fisik air *	88	100.0%	0	0.0%	88	100.0%
Kelompok	88	100.0%	0	0.0%	88	100.0%

bentuk jamban * Kelompok Crosstabulation

			Kelompok		Total
			Terpapar	Tidak terpapar	
bentuk jamban	Empang	Count	25	12	37
		% within bentuk jamban	67.6%	32.4%	100.0%
	Jamban/WC	Count	19	32	51
		% within bentuk jamban	37.3%	62.7%	100.0%

Total	Count	44	44	88
	% within bentuk jamban	50.0%	50.0%	100.0%

Lantai rumah terbuat dari * Kelompok Crosstabulation

			Kelompok		Total
			Terpapar	Tidak terpapar	
Lantai rumah terbuat dari	Tanah	Count	36	7	43
		% within Lantai rumah terbuat dari	83.7%	16.3%	100.0%
	Plester/keramik	Count	8	37	45
		% within Lantai rumah terbuat dari	17.8%	82.2%	100.0%
Total		Count	44	44	88
		% within Lantai rumah terbuat dari	50.0%	50.0%	100.0%

Lantai kamar mandi terbuat dari * Kelompok Crosstabulation

			Kelompok		Total
			Terpapar	Tidak terpapar	
Lantai kamar mandi terbuat dari	Tanah	Count	24	0	24
		% within Lantai kamar mandi terbuat dari	100.0%	0.0%	100.0%
	Plester/keramik	Count	20	44	64
		% within Lantai kamar mandi terbuat dari	31.3%	68.8%	100.0%
Total		Count	44	44	88
		% within Lantai kamar mandi terbuat dari	50.0%	50.0%	100.0%

Sumber air * Kelompok Crosstabulation

			Kelompok		Total
			Terpapar	Tidak terpapar	
Sumber air	Air sumur gali	Count	33	0	33
		% within Sumber air	100.0%	0.0%	100.0%
	PDAM	Count	11	44	55
		% within Sumber air	20.0%	80.0%	100.0%
Total		Count	44	44	88
		% within Sumber air	50.0%	50.0%	100.0%

Kualitas fisik air * Kelompok Crosstabulation

			Kelompok		Total
			Terpapar	Tidak terpapar	
Kualitas fisik air	Tidak memenuhi syarat (berbau, berasa dan berwarna)	Count % within Kualitas fisik air	44 100.0%	0 0.0%	44 100.0%
	Memenuhi syarat (Tidak berbau, berasa dan berwarna)	Count % within Kualitas fisik air	0 0.0%	44 100.0%	44 100.0%
Total		Count % within Kualitas fisik air	44 50.0%	44 50.0%	88 100.0%

Crosstabs**Case Processing Summary**

	Cases					
	Valid		Missing		Total	
	N	Percent	N	Percent	N	Percent
KatAAT * Kelompok	88	100.0%	0	0.0%	88	100.0%

KatAAT * Kelompok Crosstabulation

			Kelompok		Total
			Terpapar	Tidak terpapar	
KatAAT EED	Count	15	2	17	
	% within KatAAT	88.2%	11.8%	100.0%	
Tidak EED	Count	29	42	71	
	% within KatAAT	40.8%	59.2%	100.0%	
Total		Count	44	44	88
		% within KatAAT	50.0%	50.0%	100.0%

Crosstabs**Case Processing Summary**

	Cases					
	Valid		Missing		Total	
	N	Percent	N	Percent	N	Percent
KatLILA28 * Berat Badan Lahir	88	100.0%	0	0.0%	88	100.0%
KatSanitasi * Berat Badan Lahir	88	100.0%	0	0.0%	88	100.0%
KatAAT * Berat Badan Lahir	88	100.0%	0	0.0%	88	100.0%

KatLILA28 * Berat Badan Lahir

Crosstab

			Berat Badan Lahir		Total
			BBLR (<2500gr)	BBLN (≥500gr)	
KatLILA28	KEK (<23.5cm)	Count	12	32	44
		% within KatLILA28	27.3%	72.7%	100.0%
	Normal (≥23.5 cm)	Count	2	42	44
		% within KatLILA28	4.5%	95.5%	100.0%
Total		Count	14	74	88
		% within KatLILA28	15.9%	84.1%	100.0%

Chi-Square Tests

	Value	df	Asymptotic Significance (2-sided)	Exact Sig. (2-sided)	Exact Sig. (1-sided)
Pearson Chi-Square	8.494 ^a	1	.004		
Continuity Correction ^b	6.880	1	.009		
Likelihood Ratio	9.280	1	.002		
Fisher's Exact Test				.007	.003
Linear-by-Linear Association	8.398	1	.004		
N of Valid Cases	88				

a. 0 cells (.0%) have expected count less than 5. The minimum expected count is 7,00.

b. Computed only for a 2x2 table

Risk Estimate

	Value	95% Confidence Interval	
		Lower	Upper
Odds Ratio for KatLILA28 (KEK (<23.5cm) / Normal (≥23.5 cm))	7.875	1.645	37.701
For cohort Berat Badan Lahir = BBLR (<2500gr)	6.000	1.425	25.259
For cohort Berat Badan Lahir = BBLN (≥500gr)	.762	.629	.923
N of Valid Cases	88		

KatSanitasi * Berat Badan Lahir**Crosstab**

			Berat Badan Lahir		Total
			BBLR (<2500gr)	BBLN (≥500gr)	
KatSanitasi	sanitasi kurang	Count % within KatSanitasi	12 27.3%	32 72.7%	44 100.0%
	sanitasi baik	Count % within KatSanitasi	2 4.5%	42 95.5%	44 100.0%
Total		Count % within KatSanitasi	14 15.9%	74 84.1%	88 100.0%

Chi-Square Tests

	Value	df	Asymptotic Significance (2- sided)	Exact Sig. (2-sided)	Exact Sig. (1-sided)
Pearson Chi-Square	8.494 ^a	1	.004		
Continuity Correction ^b	6.880	1	.009		
Likelihood Ratio	9.280	1	.002		
Fisher's Exact Test				.007	.003
Linear-by-Linear Association	8.398	1	.004		
N of Valid Cases	88				

a. 0 cells (.0%) have expected count less than 5. The minimum expected count is 7,00.

b. Computed only for a 2x2 table

Risk Estimate

	Value	95% Confidence Interval	
		Lower	Upper
Odds Ratio for KatSanitasi (sanitasi kurang / sanitasi baik)	7.875	1.645	37.701
For cohort Berat Badan Lahir = BBLR (<2500gr)	6.000	1.425	25.259
For cohort Berat Badan Lahir = BBLN (≥500gr)	.762	.629	.923
N of Valid Cases	88		

KatAAT * Berat Badan Lahir**Crosstab**

			Berat Badan Lahir		Total
			BBLR (<2500gr)	BBLN (≥500gr)	
KatAAT	EED	Count	13	4	17
		% within KatAAT	76.5%	23.5%	100.0%
	Tidak EED	Count	1	70	71
		% within KatAAT	1.4%	98.6%	100.0%
Total		Count	14	74	88
		% within KatAAT	15.9%	84.1%	100.0%

Chi-Square Tests

	Value	df	Asymptotic Significance (2-sided)	Exact Sig. (2-sided)	Exact Sig. (1-sided)
Pearson Chi-Square	57.766 ^a	1	.000		
Continuity Correction ^b	52.291	1	.000		
Likelihood Ratio	48.055	1	.000		
Fisher's Exact Test				.000	.000
Linear-by-Linear Association	57.110	1	.000		
N of Valid Cases	88				

a. 1 cells (25,0%) have expected count less than 5. The minimum expected count is 2,70.

b. Computed only for a 2x2 table

Risk Estimate

	Value	95% Confidence Interval	
		Lower	Upper
Odds Ratio for KatAAT (EED / Tidak EED)	227.500	23.507	2201.723
For cohort Berat Badan Lahir = BBLR (<2500gr)	54.294	7.618	386.956
For cohort Berat Badan Lahir = BBLN (≥500gr)	.239	.101	.563
N of Valid Cases	88		

Lampiran 9. Output Amos

Number of variables in your model: 7
 Number of observed variables: 4
 Number of unobserved variables: 3
 Number of exogenous variables: 4
 Number of endogenous variables: 3

	Weights	Covariances	Variances	Means	Intercepts	Total
Fixed	3	0	0	0	0	3
Labeled	0	0	0	0	0	0
Unlabeled	6	0	4	0	0	10
Total	9	0	4	0	0	13

Number of distinct sample moments: 10

Number of distinct parameters to be estimated: 10

Degrees of freedom (10 - 10): 0

Estimates (Group number 1 - Default model)

Scalar Estimates (Group number 1 - Default model)

Maximum Likelihood Estimates

Regression Weights: (Group number 1 - Default model)

		Estimate	S.E.	C.R.	P	Label
LILA28	<--- Total_Sanitasi	,546	,086	6,328	***	
AAT	<--- Total_Sanitasi	10,224	2,911	3,512	***	
AAT	<--- LILA28	-13,589	2,991	-4,543	***	
BBLRASIO	<--- AAT	-3,382	1,172	-2,885	,004	
BBLRASIO	<--- Total_Sanitasi	-41,251	34,010	-1,213	,225	
BBLRASIO	<--- LILA28	160,352	36,377	4,408	***	

Standardized Regression Weights: (Group number 1 - Default model)

		Estimate
LILA28	<--- Total_Sanitasi	,561
AAT	<--- Total_Sanitasi	,407
AAT	<--- LILA28	-,526
BBLRASIO	<--- AAT	-,276
BBLRASIO	<--- Total_Sanitasi	-,134
BBLRASIO	<--- LILA28	,506

Variances: (Group number 1 - Default model)

	Estimate	S.E.	C.R.	P	Label
Total_Sanitasi	2,545	,386	6,595	***	
e3	1,651	,250	6,595	***	
e1	1285,055	194,839	6,595	***	
e2	153616,229	23291,232	6,595	***	

Matrices (Group number 1 - Default model)**Total Effects (Group number 1 - Default model)**

	Total_Sanitasi	LILA28	AAT
LILA28	,546	,000	,000
AAT	2,800	-13,589	,000
BBLRASIO	36,897	206,307	-3,382

Standardized Total Effects (Group number 1 - Default model)

	Total_Sanitasi	LILA28	AAT
LILA28	,561	,000	,000
AAT	,111	-,526	,000
BBLRASIO	,120	,651	-,276

Direct Effects (Group number 1 - Default model)

	Total_Sanitasi	LILA28	AAT
LILA28	,546	,000	,000
AAT	10,224	-13,589	,000
BBLRASIO	-41,251	160,352	-3,382

Standardized Direct Effects (Group number 1 - Default model)

	Total_Sanitasi	LILA28	AAT
LILA28	,561	,000	,000
AAT	,407	-,526	,000
BBLRASIO	-,134	,506	-,276

Indirect Effects (Group number 1 - Default model)

	Total_Sanitasi	LILA28	AAT
LILA28	,000	,000	,000
AAT	-7,425	,000	,000
BBLRASIO	78,148	45,955	,000

Standardized Indirect Effects (Group number 1 - Default model)

	Total_Sanitasi	LILA28	AAT
LILA28	,000	,000	,000

		Total_Sanitasi	LILA28	AAT			
AAT		-,295	,000	,000			
BBLRASIO		,253	,145	,000			
	M.I.	Par Change					
	M.I.	Par Change					
	M.I.	Par Change					
Iteration		Negative eigenvalues	Condition #	Diameter	F	NTries	Ratio
0	e	0	18,220	9999,000	89,093	0	9999,000
1	e	0	34,610	1,055	39,389	3	,000
2	e	0	10,529	,483	8,538	1	1,097
3	e	0	5,882	,134	1,424	1	1,211
4	e	0	5,334	,075	,090	1	1,146
5	e	0	4,943	,026	,001	1	1,053
6	e	0	4,996	,002	,000	1	1,005
7	e	0	5,175	,000	,000	1	1,000
Model		NPAR	CMIN	DF	P	CMIN/DF	
Default model		10	,000	0			
Saturated model		10	,000	0			
Independence model		4	92,101	6	,000	15,350	
Model		RMR	GFI	AGFI	PGFI		
Default model		,000	1,000				
Saturated model		,000	1,000				
Independence model		2757,596	,692	,487	,415		
Model		NFI Delta1	RFI rho1	IFI Delta2	TLI rho2	CFI	
Default model		1,000		1,000		1,000	
Saturated model		1,000		1,000		1,000	
Independence model		,000	,000	,000	,000	,000	
Model		PRATIO	PNFI	PCFI			
Default model		,000	,000	,000			
Saturated model		,000	,000	,000			
Independence model		1,000	,000	,000			
Model		NCP	LO 90	HI 90			
Default model		,000	,000	,000			
Saturated model		,000	,000	,000			
Independence model		86,101	58,684	120,961			

Model	FMIN	F0	LO 90	HI 90
Default model	,000	,000	,000	,000
Saturated model	,000	,000	,000	,000
Independence model	1,059	,990	,675	1,390

Model	RMSEA	LO 90	HI 90	PCLOSE
Independence model	,406	,335	,481	,000

Model	AIC	BCC	BIC	CAIC
Default model	20,000	21,220	44,773	54,773
Saturated model	20,000	21,220	44,773	54,773
Independence model	100,101	100,589	110,011	114,011

Model	ECVI	LO 90	HI 90	MECVI
Default model	,230	,230	,230	,244
Saturated model	,230	,230	,230	,244
Independence model	1,151	,835	1,551	1,156

Model	HOELTER	HOELTER
	.05	.01
Default model		
Independence model	12	16

Minimization: ,024

Miscellaneous: ,328

Bootstrap: ,000

Total: ,352

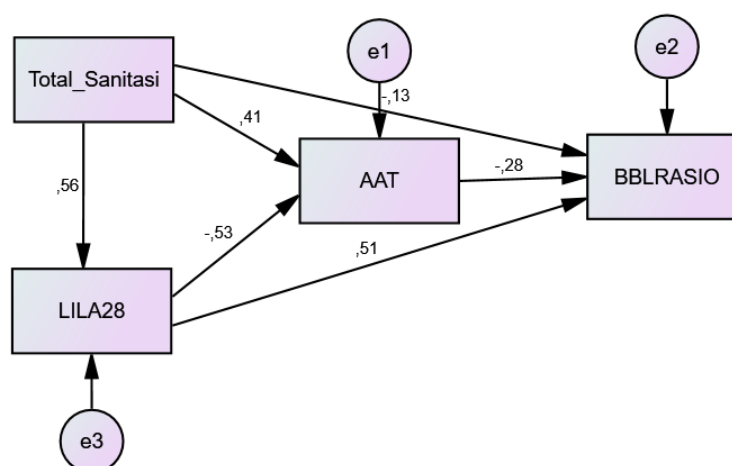

Lampiran 11. Dokumentasi penelitian



Wadah Sampel Feses Ibu Hamil



Pita Pengukuran LILA Ibu Hamil

Wawancara Pengisian Lembar Observasi Peneliti dan Ibu Hamil



Pengukuran LILA Ibu Hamil Oleh Enumerator



Keadaan Jamban



Pemberian Reward



Wawancara Pengisian Lembar Observasi Peneliti dan Ibu Hamil



Pengukuran LILA Ibu Hamil Oleh Enumerator



Sumber Air Bersih (Sumur Gali) Ibu Hamil



Pemberian Reward



Lantai Rumah Terbuat dari Plester



Lantai Rumah Terbuat dari Tanah dan Bentuk Jamban WC/Septic Tank



Lampiran : Dokumentasi RSIA Kartini Makassar



Lampiran : Dokumentasi RS Unhas Makassar



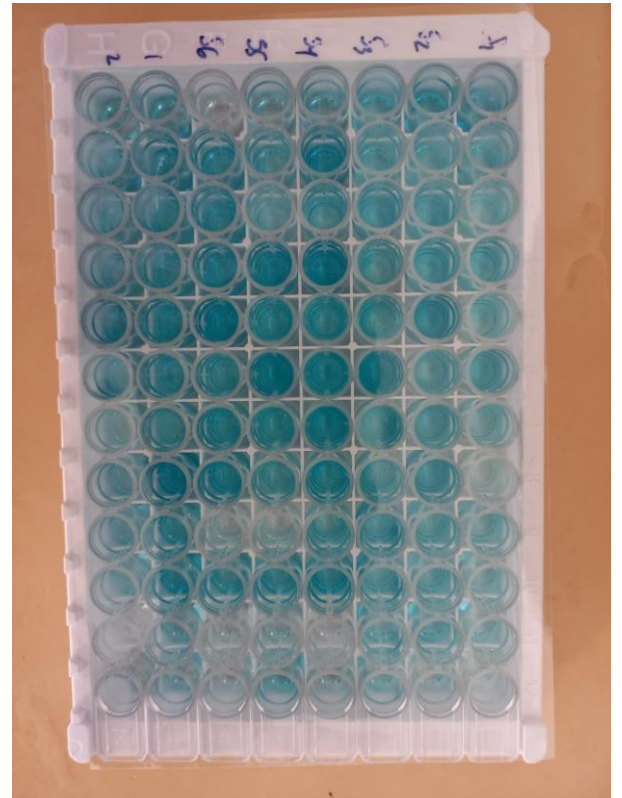

Lampiran 12. Biodata Penulis

A. Identitas Diri

Nama : Asriana Abdullah, S.Si., S.Pd., M.Kes
 Tempat/Tanggal Lahir : Ujung Pandang/07 Agustus 1984
 Suku/Bangsa : Makassar/Indonesia
 Agama : Islam
 Pekerjaan : Dosen
 Alamat : Jl. Paccinang II Kompleks Kejaksaan No.36 A
 No. HP : 082316805030



B. Keluarga

Ayah : Abdullah Beta Dg. Ngeppe (Alm)
 Ibu : Zaenab L. Kr. Karaeng
 Saudara : - Fatmawati Abdullah, SKM.
 - Rahmawati Abdullah, SH., M.Kn.
 - Muhammad Arief Abdullah, SE.
 - Dr. Mirawati Abdullah, S.Pd., M.Pd.
 - Agustianita Abdullah, SE.
 - Megawati Abdullah, SE.
 - Dr. Muhammad Nur Abdullah, S.Pd., M.Pd.
 - Nur Indah Abdullah, SH.
 Suami : Nasrun Julyarman, SE., M.Si.
 Ayah Mertua : Raden Amar (alm)
 Ibu Mertua : Rachmatia
 Anak : - Andi Fatimah Azzahra Asfah
 - Andi Muhammad Zulkifli Karim
 - Andi Siti Maryam Mappa

C. Riwayat Pendidikan

1. SDN. Paccinang Makassar	Tamat 1997
2. SMPN. 23 Makassar	Tamat 2000
3. SMUN. 12 Makassar	Tamat 2003
4. S1 Biologi Universitas Hasanuddin	Tamat 2008
5. S1 Ke-2 Pendidikan Biologi UNM	Tamat 2010
6. S2 Ilmu Biomedik Universitas Hasanuddin	Tamat 2014
7. Pendidikan Doktor FKM UNHAS Makassar	Tamat 2022

D. Riwayat Pekerjaan

	Tahun
1. Guru Honorer SDN. Paccinang 1 Makassar	2005 - 2009
2. Tenaga Tutor Bimbingan Belajar MPC Makassar	2007 - 2009
3. LIS Prodia Tbk Kota Pare-Pare	2009 - 2010
4. <i>Caroline Officer</i> Infomedia Telkomsel Makassar	2010 - 2011
5. Guru Sekolah Islam Athirah Makassar	2011 - sekarang
6. Dosen Universitas Andi Djemma Palopo	2016 - sekarang

E. Riwayat Publikasi Scopus:

No.	Judul	Nama Jurnal
1.	Development of Health Education Model (Vaginal Hygiene) in Vaginal Candidiasis Prevention in Pregnant	Enfermeria Clinica https://doi.org/10.1016/j.enfcli.2019.10.060
2.	The Relationship Between Biomarkers of Environmental Enteric Dysfunction with Vulvovaginal Candidiasis In Pregnant Mothers and Pregnancy Outcome (Stunting): A Literature Review	<i>Nat. Volatiles & Essent. Oils</i> , 2021; 8(4): 13-20

3. The Relationship Between Environmental Enteric Dysfunction Biomarkers, Vulvovaginal Candidiasis, And Pregnancy Outcome In Pregnant Mothers (Stunting) Turkish Journal of Physiotherapy and Rehabilitation; 32(3) ISSN 2651-4451 | e-ISSN 2651-446X
4. The Determinant Of Environmental Enteric Dysfunction (Eed) Influence Of Candida Sp On Women With Pregnancy In Makassar Turkish Journal of Physiotherapy and Rehabilitation; 32(3) ISSN 2651-4451 | e-ISSN 2651-446X
5. Determinants of Environmental Enteric Dysfunction in Mothers on Infant Birth Weight in Makassar *Nat. Volatiles & Essent. Oils*, (NVEO_2021_2532) (LoA)