

Financial Performance Information and Voters' Behavior for the Re-election of Incumbent Regional Heads

Darmawati Darmawati¹, Ratna Ayu Damayanti²

(darma.ak@unhas.ac.id¹, ratna.ayu@fe.unhas.ac.id²)

Faculty of Economics and Business, Hasanuddin University, Makassar, Indonesia.^{1,2}

ABSTRACT

The aim of the research is to examine the extent to which performance information influences the voters' behavior in the re-election of the ruling regional head. Based on information content theory and Rational Choice Theory empirically in analyzing the incumbent re-election relationship as the dependent variable, and financial performance variables consisting of financial independence, the level of budget absorption, and the ratio of debt to income. This research used quantitative research method with secondary data sources from 215 incumbents. Sample selection was purposive sampling. Data were analyzed by multiple linear analysis. Empirical results indicated that financial performance information on financial independence and budget absorption rates had a positive effect on re-election incumbent, the debt ratio had no effect. The results of this study were important because they can be a reference for incumbents to determine policies, for voters can be used as a basis for assessing the incumbent's performance before making a choice.

Keywords:

performance information, incumbent, regional head, re-election and voters' behavior.

Article Received: 18 October 2020, Revised: 3 November 2020, Accepted: 24 December 2020

1 Introduction

Performance information is the main source that discusses second politics for politicians after feedback is obtained through face-to-face interactions with local residents [1]. Politicians want to play the role of an ombudsman and pay attention to evaluate the aspirations and actual performance of local governments. The information that can be used by supporting and articulating such deviations. While [2], the agreement of the regional head as a decision-maker requires information and includes an agenda in what will be discussed in the future. Accounting and measurement information are needed for making decision and accountability for information expected to be available for internal and external purposes [3].

The accountability reports on the administration of local government is one of the bases for voters to make decisions on regional head elections, and the reporting information can influence the reaction of the election [4]. In rational condition, voter votes are a reflection of

all information that is received by voters. Smart voters will use government information related to regional head election databases. According to [5] the quality of financial reporting and information determines election results. [6] Which shows that elections have good access to information (knowledgeable voters) will influence political attitudes and preferences, positively. The better politics will lead to an increase of local government. One thing to analyze the performance of local governments is the analysis of financial ratios to the regional budget.

[13] Information on financial performance that can be used to measure the performance of local governments, among others: support, growth, and independence ratios, a ratio of growth to revenue, level of budget acquisition, etc.

In Indonesia, the contradiction arises during the regional head election is the existence of a strong patronage relationship between candidates and voters, corruption, and the rise of political money [9]. Voter Choices incompatibility of votes and loyalty to choose certain candidates, choosing

candidates has the right to give cash only, but also make other contributions during the election period [10], voters are irrational and do not pay attention to incumbent candidates. While according to [11] rational action gives consideration to social action, it seems illogical or does not consider rational. The highest control of the electorate over incumbents, they choose the ballot box [12].

The purpose of the study was to determine how much information was needed about the incumbent regional head election. With local government financial budgets consisting of financial independence, budget acquisition, debt to income ratio. The assumption underlying of this research is the selection decision taken by sufficient information for making decision. Part 2 Conceptual Framework and Hypothesis Development, Part 3 containing Data and Analysis Method, Part 4 Results and discussion, section 5 Conclusion.

2 Conceptual Framework and Hypothesis Development

2.1 Theoretical Based

Rational Choice Theory

Rational Choice Theory is a theory that encourages humans as actors in the election; the choice is a step to determine their interests as actors and resources [13]. [14], they do not care what has been chosen or become an important choice accepted. The core of this theory is about every choice based on human decisions. This theory helps to provide logical conclusions [15]. Thus, the theory of rational choice as a means of achieving the objectives or means of choice of actors in the interests of regional elections.

Democratic party or election as an opportunity in the process of leadership transition from the presidential level (central) to the regions. After implementing direct election in Indonesia in 2005 and ratification of Law Number 32 the Year 2004 concerning Regional Governments, it has further strengthened Indonesia as a democratic country [16]. Realistic actions give thought to

social action appear to be illogical or unreasonable [11], [17] said when actors want to make choices; rational choice theories help to explain and support the selection.

Financial Performance Information

Accounting information can reflect the results of public policy and its consequences as a vehicle for communicating the economic effects of political management. [18] His article examines the relationship between financial reporting and voting behavior in 143 cities in Spain, the results of his research indicated that election results are influenced by financial information. Government financial reporting must provide information to help users assess their economic, social and political accountability and making decision.

[8] Writing that financial performance analysis is an effort to identify financial characteristics based on available financial statements. Public organizations such as the government in measuring financial performance apply several performance measures that are used, namely: independence, effectiveness, efficiency, harmony, and growth ratios. [19] States that measuring the performance of the regional financial budget is very important because it records and evaluates how much the achievement of an implementation of an activity is based on the objectives, targets, and strategies set. Information on financial performance used in this study is the ratio of financial independence, the level of budget absorption, and the ratio of debt to income.

Regional Financial Independence

Regional financial independence is an indicator of the ability of local governments to finance their own government, development, and public services for people who have met the requirements in paying taxes, levies, and intergovernmental transfers of loans [8] and [20]

The formula for independence ratio is calculated by the formula:

$$\text{Financial Independence Ratio} = \frac{\text{Locally-generated revenue}}{\text{Central assistance} + \text{loans}} \times 100\%$$

Budget Absorption Rate

The level of budget absorption is the proportion of work unit budget that has been disbursed or realized in one budget year [21]. Budget absorption measurement, i.e. comparison of available funds and actual expenditure. However, certain treatments are needed. If 100% of the allocated budget is spent there, it may be absorptive capacity which causes the reallocation of funds and / or failure to implement the work plan.

The performance of public managers is assessed based on the achievement of budget targets that have been achieved [21], [22], [23]. High and low absorption of the budget in local governments to measure the performance of the success of the local government.

The budget absorption rate is calculated by using the formula:

$$\text{budget absorption rate} = \frac{\text{Realization of APBD}}{\text{The budget of APBD}} \times 100\%$$

Ratio of Debt to Regional Revenue

Debt to Regional Income Ratio. The lower of the value of this ratio the better. Knowledge of the ratio helps financial difficulties in providing loans or credit in the future. [20] The debt to total income ratio is calculated by using the following formula.

$$\text{Debt To Revenue Ratio} = \frac{\text{Total Debt}}{\text{Total Regional Revenue}} \times 100\%$$

2.2 Hypothesis Development

The influence of financial independence on the re-election of the Incumbent regional head

The basic assumption of rational choice theory is the actors make rational choices over rational actions that are intentionally made to maximize their profits. In the government sector, the actors are rational actors, including politicians, bureaucrats, voters (in various electoral events) and economic actors [24]. In deciding the choices to be taken by actors, this theory is proposed to provide an explanation of the optimal choices for making decision. Rational choice theory is a

theory used to answer the best decisions in meeting the demands of actors in their environment [25]. Regional financial independence shares information about local governments in terms of financing their own local government, development, and governance of community heads, it can be interpreted by increasing regional income and community welfare.

The results of research conducted by [26] found a significant relationship between increasing regional income and the level of incumbent re-election. In line with the research [27] suggested a positive and significant profit acquisition of incumbent re-election. Likewise, the results of the study [28] found that higher income from direct government transfers affected them in the re-election of incumbents. Research results [29] found evidence of a direct tax ratio to total revenue proving positive for the re-election of incumbents in Portugal. Contrary to the results of the study [17] the regional financial independence did not have a significant direct effect on the re-election of the incumbent regional head candidate. This, discussing any high or low performance of the government in terms of financial independence will not affect the re-election in the regional head elections. Rational voters will elect incumbent regional head candidates by looking at their performance in the previous tenure which can increase financial independence. Based on these considerations the research hypothesis was formulated as follows:

H1: positive financial independence towards the re-election of the incumbent regional heads.

Effect of budget absorption rate against the re-election of the incumbent regional head

The level of budget raising that will indicate the ability of regional heads to be able to determine budget targets in accordance with the budget limit set by the program. The results of the study [29] found a positive level of budgetary assistance for incumbent re-election. The results of the study [28] found a positive refutation versus being re-elected, incumbent. It is the same with

[38] Find out US elections punishes governments that increase public support accepting elections. The basic assumption of the budget level, the higher of the budget level, the higher of the level of the incumbent regional head to re-election. Based on these considerations, the research hypothesis is formulated as follows:

H2: Attractive level of the positive budget towards the re-election of the incumbent regional head.

Effects of Debt Ratio on Income Influence on Re-election of Incumbent Regional Head

The low fiscal capacity to reduce the burden of government debt is reflected in the primary balance indicator in the regional budget which is not good. This indicates that fiscal health (fiscal sustainability) is in a dangerous condition. [30] examines the factor of the ratio of debt to income so that voters can rationally see the achievements of the incumbent regional head by not only paying attention to the achievements of the development of the real sector but also paying attention as a basis for making decision in the voting booth. The debt-to-income ratio must be carefully considered before voting because debt payments will be passed on to the people as the principal and to the next government. Based on the theory of rational choice, the researchers examine whether voters rationally consider the ratio of debt to income at the time of the regional head election.

The results of research on the influence of debt variables in incumbent re-election include a study conducted by [31] He found that the most relevant variable that was taken into account by

citizens/voters in making decision related to municipal government debt. Therefore, debt reduction has a positive effect on re-election incumbent. However, the results obtained in the study [32] indicate the level of municipal debt does not affect voting decisions or election results. While the results of research [29] in Portugal found evidence that the variable total debt per total income had a negative effect on the re-election of incumbents.

These findings indicate that the greater the volume of debt generated by local governments, the lower of the chances of winning in re-election. [33] studied the impact of debt accumulation on the possibility of the re-election of local governments in France. This research shows that the accumulation of debt during the tenure has a negative impact on the re-election. Conversely, debt accumulation before the election is preferred by voters by re-electing the incumbent. [34] found that the voters penalizing high levels of debt during their entire tenure and loan income negatively affected the incumbent's re-election [28].

The assumption that is built from the debt to revenue ratio is the lower the debt ratio, the higher the incumbent's re-election level. Based on these considerations the research hypothesis was formulated as follows:

H3: The debt to revenue ratio has a negative effect on the re-election of the incumbent regional head.

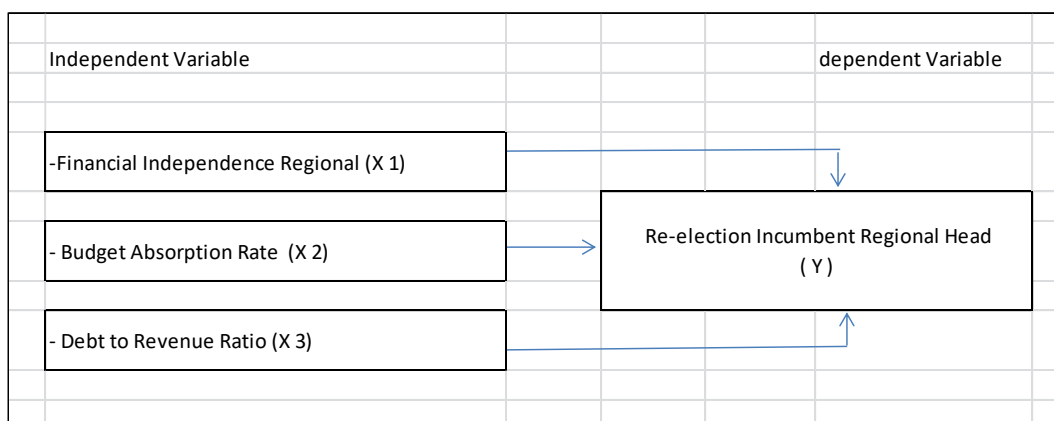

Fig. 1. Research Models

3 Data and Analysis Methods

Quantitative research methods with secondary data sources from 215 incumbents. Sample selection was purposive sampling. Data were analyzed by multiple linear analyses. The population of this study was the provincial government, district government, the government of City in the territory of Indonesia which held simultaneous regional head elections in 2017 and 2018.

The model developed for this analysis is as follows:

$$Y = \beta_0 + \beta_1X_1 + \beta_2X_2 + \beta_3X_3 + e$$

Notes:

Y : Re-election Incumbent

β_0 : constant

$\beta_1- \beta_3$: Coefficient of regression direction

X1 : Financial independence

X2 : Budget Absorption Rate

X3 : Debt of Revenue Ratio

e : Confounding variable (error)

4 Results and Discussion

The results of multiple linear regression testing can be seen in Table 1.

Table 1. Results of multiple linear regression analysis

Effect of Research Variables	Regression Coefficient t	Standard Error	t-statistic	Prob.	Notes
Konstanta	-10,512	2,469	-4,257	0,000	
X1 → Y	0,459	0,084	5,450	0,000	Significant
X2 → Y	0,927	0,134	6,918	0,000	Significant
X3 → Y	-0,161	0,108	-1,498	0,136	Not Significant
R ² = 0,367					
F hitung = 14,312					
Sig. F hitung = 0,000					

Source: Data Processed, 2019

R-square determination coefficient value on the test results of the variables above shows that the value of 0.367 or 36.70% and the remaining 63.30% was influenced by other variables outside the independent variables examined in this study.

Based on the results of the regression test above, mathematical equations can be arranged as follows.

$$Y = -10,512 + 0,459X_1 + 0,927X_2 - 0,161X_3 + e$$

Hypothesis testing in this study was carried out partially using the t test which can be seen as follows.

Financial Independence has a Positive Impact on the re-election of Regional Incumbent Head

In the financial independence variable (X1) obtained a probability value of 0,000. Because the probability value was less than 5 percent (0.000 < 0.05), then the financial independence variable (X1) partially had a significant effect on the inclusion of the incumbent regional head variable (Y). Based on the coefficient value of 0.459 was positive, identifying the positive effect. From the results of testing hypothesis 1, it can be concluded that financial independence provides the incumbent's chance to be re-elected. It means that the greater of the financial independence, the greater of the chance of electing the incumbent. In line with the research results of [26], [27], [28], [29]. But it is not in line with research [17]. The

results of the study were in line with rational choice theory.

The Level of Budget Absorption Has a Positive Impact on the re-election of Incumbent Regional Heads

Based on the coefficient value 0.927 was positive, identifies the positive effect. This means that the higher of the level of budget absorption (X2), the higher of the electability of the incumbent regional head (Y). Conversely, the lower of the level of budget absorption (X2) the lower of the elected head of the incumbent (Y). The results showed that if an increase in the value of the variable absorption rate of the budget by 1 percent would increase the elected head of the incumbent region by 0.927 percent. It means that the greater of the level of budget absorption, the greater of the chance of electing the incumbent. In line with the results of research was conducted by [35] but contrary to research [27], [29], [36], [38]. Rational choice theory is proven, the greater of the preference received by voters, the voters will re-elect the incumbent regional head.

Debt-to-Income Ratio Negatively Influences the re-election of Incumbent Regional Heads

The income (X3) obtained a probability value of 0.136 in the variable ratio of debt. Because the probability value was greater than 5 percent ($0.136 < 0.05$), then partially the ratio of debt to income (X3) variable had a significant effect on the electability of the incumbent regional head (Y). Based on the coefficient value -0.161 was negative, identifying the negative effect. It means that the level of debt to income ratio (X3), did not affect the electability of the incumbent regional head (Y). The empirical results from the relationship of the debt ratio to the electability of incumbent regional heads showed that there was no significant negative result on the inclusion of incumbent regional heads. It shows that the ratio of debt to income did not affect the elected head of the incumbent region. The reason for the insignificance of these results was probably because the data on the ratio of debt to income

was not normally distributed. It can be seen from the results of descriptive statistics that showed a minimum debt ratio of Sukabumi city of 0.12, a maximum of 51.66, an average value of 4.62, and a standard deviation of 7.41 greater than mean score. This study is in line with the results of research conducted by [35] but it was contradiction with research [27], [29], [36], [38]. The results of the study are supportive of rational choice theory.

5 Conclusion

Financial independence has a positive and significant effect on the re-election of regional incumbent heads. It means that the higher of the financial independence the greater of the chances of incumbent re-elected. The level of budget absorption has a positive and significant impact on the re-election of the incumbent's regional head, it means that the higher of the level of budget absorption, the greater of the chances of incumbent re-elected. The debt ratio does not have a significant effect on the re-election of the incumbent regional head; it means that voters do not consider the capacity of the regional government debt when they vote.

6 Acknowledgments:

This research is a part of the first author's dissertation titled "The Political budget Cycle and Performance information on The Selection of Incumbent Regional Head", The dissertation was funded by Ministry of Research, Technology and Higher Education of the Republic of Indonesia (Kemenristekdikti) grant #01/E/KTP/2018.

References

- [1] Askim, J. How do politicians use performance information? An analysis of the Norwegian local government experience. *International Review of Administrative Sciences*, 73(3), 453–472. doi:10.1177/0020852307081152, (2007).
- [2] Nicholson-Crotty, Sean, Theobald, Nick A. and Nicholson-Crotty, Jill 'Disparate

- Measures: Public Managers and Performance-measurement Strategies', *Public Administration Review* 66(1): 101–13. (2006)
- [3] Cohen, Sandra, Francesca Manes Rossi, Eugenio Caperchione, Isabel Brusca.: Local government administration systems and local government accounting information needs: is there a mismatch? *International Review of Administrative Sciences* 0(0) 1–18 DOI: 10.1177/0020852317748732. (2018)
- [4] Darmawati, Mediaty, Gagaring Pagalung, Ratna Ayu Damayanti. Performance Assessment and Opportunities for Incumbent Regional Heads. *Quest Journals Journal of Research in Business and Management* Volume 7 ~ Issue 3, pp: 82-88, ISSN(Online): 2347-3002. (2019)
- [5] Fernandes, M., Gomes, P., & Silva, C. Accounting Information and Voter's Behaviour: Empirical Research in Portuguese Municipalities. *Asociación Española de Contabilidad y Administración de Empresas (AECA), XV Encuentro AECA "Nuevos Caminos para Europa: El Papel de las Empresas y los Gobiernos"*, 106a. Retrieved from http://www.aeca.es/pub/on_line/comunicaciones_xvencuentroaeca/cd/106a.pdf (2012).
- [6] Zaller, John. *The Nature and Origins of Mass Opinion*. New York: Cambridge University Press. (1992).
- [7] Haliah, Gagaring, Mediaty, Mushar.: The Effect of Budgeting Participation, and Slack Budget in Relationship Between Politic, Culture, and Regulation to Financial Performance, Volume XII, Issue 2 (48) Spring 2017 ISSN-L 1843 – 6110 ISSN 2393 - 5162 374-390 (2017).
- [8] Halim, Abdul. *Akuntansi Sektor Publik: Akuntansi Keuangan Daerah*. Edisi Revisi. Jakarta: Salemba Empat (2013).
- [9] Mietzner, M. Indonesia's direct elections: empowering the electorate or trenching the new order oligarchy? In: Aspinall, E., Fealy, G. (Eds.), *Soeharto's New Order and its Legacy*. ANU E Press, Canberra, pp. 173–190. (2010).
- [10] Simandjuntak, D. Gifts and promises: patronage democracy in a decentralised Indonesia. *European Journal of the East Asian Studies* 11 (1), 99–128. (2012)
- [11] Asworth, Scott. Ethan Bueno de Mesquitadan Amanda Friedenberg. "Accountability and Information in Election." *American Economic Journal: Microeconomics* Vol.9, No 2, May (2016).
- [12] Darmawati; Ratna Ayu Damayanti; Gagaring Pagalung; Mediaty. Opportunistic Political Budget Cycle and Re-Election Incumbent, *International Journal of Innovative Science and Research Technology*. Volume 4, Issue 4, April – 2019 ISSN No: -2456-2165. (2019)
- [13] Coleman, J. S. *Foundations of Social Theory*. Cambridge: Belknap, (1990).
- [14] Ritzer G. dan Douglas J. Goodman. *Modern Sociological Theory* 7th Edition. McGraw Hill Publisher (2007).
- [15] Waltz, Stephen M. *Rigor or Rigor Mortis? Rational Choice and Security Studies*. MIT Press Journals. Spring. (1999).
- [16] Haikal, Ali Muhammad. *Peta Petahanadan Potensi Politisasi Birokrasi. Konstitusi dan Demokrasi (KoDe) Inisiatif*. www.kodeinisiatif.org (2015).
- [17] Sulaiman, Syarif Hidatullah. *Akuntabilitas Electoral di Indonesia : Pengaruh kandungan informasi kinerja Pemerintah terhadap terpilihnya Petahana*, Tesis, Universitas Hasanuddin. (2017).
- [18] Brusca, Isabel dan Vicente Montesisos. "Are Citizens Significant Users of Government Financial Information? Public Money & Management." *Journal Compilation*, 205-209 <http://dx.doi.org/10.1111/j.1467-302.2006.00526.x> (2006).
- [19] Ekawarna, Shita Unjaswati, Iskandar Sam dan Sri Rahayu.

- Pengukuran Kinerja Anggaran Pendapatan dan Belanja Daerah (APBD) Pemerintah Daerah Kabupaten Muaro Jambi. *Jurnal Cakrawala Akuntansi*, Volume 1, No. 1, Februari (2009).
- [20] Mahmudi. Analisis Laporan Keuangan Pemerintah Daerah: Panduan Bagi Eksekutif, DPRD, dan Masyarakat Dalam Pengambilan Keputusan Ekonomi, Sosial dan Politik, Edisi 2. UPP STIM YKPN. Yogyakarta. 2010.
- [21] Noviwijaya, A. & A. Rohman. Pengaruh Keragaman Gender dan Usia Pejabat Perbendaharaan Terhadap Penyerapan Anggaran Satuan Kerja (Studi Empiris pada Satuan Kerja Lingkup Pembayaran KPPN Semarang I). Diponegoro. *Journal of accounting*. Vol. 2 (3): 1-10. (2013).
- [22] Mardiasmo. *Akuntansi Sektor Publik*. Edisi Rev. Yogyakarta: Andi. Yogyakarta. (2009).
- [23] Wibisono, Andri & Rodhiyah. "Analisis Kinerja Keuangan pada PT. Bank Muamalat Indonesia Periode 2005-2009". *Jurnal Administrasi Bisnis*, Vol. 1 No. 1, September 2012, Universitas Diponegoro, Semarang. (2012).
- [24] Rafiuddin, Rianty. Modul Ilmu Politik, repository.ut.ac.id>IPEM4215-M1(2014)
- [25] Erikson, Robert dan Gerald Wright. "Voters, Candidates, and Issues in Congressional Elections," in *Congress Reconsidered*, edited by Lawrence Dodd and Bruce Oppenheimer. 7th Edition, Washington D.C.: CQ Press. (2001).
- [26] Rumayya, Batubara. Electoral Accountability of Local Government in Post-Decentralized Indonesia: Does Economy Matters? The 12th IRSA International Conference. 2-3 Juni 2014, Makassar South Sulawesi, Indonesia. (2014).
- [27] Balaguer-Coll, M., & Brun-Martos, M. El Efecto del Gasto P ublico sobre las Posibilidades de Reelecci3n de los Gobiernos Locales. *The Accounting Review*, 16(1), 74–80. (2013).
- [28] Chortareas, Georgios, Vasileios Logothetis, & Andreas A. Papandreou. Political Budget Cycle and Reelection Prospects in Greece's Municipalities, *European Journal of Political Economy*. doi: 10.1016/j.ejpoleco.2016.02.001. (2016).
- [29] Cunha, Ana Maria, Augusta Ferreira dan maria Jose Fernandes. The Influence of Accounting Information and Social Economic Factors in the Re-Election of Portuguese the Mayors. A volume in the *Advances in Finance, Accounting, and Economics (AFAE) Book Series*. Chapter 19. Information Science Reference (an imprint of IGI Global). (2018).
- [30] Mulyadi. Pengaruh Pendapatan Asli Daerah terhadap Penyelenggaraan Pembangunan Daerah (Suatu Studi di Kabupaten Kepulauan Sula). *Governance Jurnal Ilmu Jurusan Ilmu Pemerintah FISIP Unsrat Vol.5 No.1*, Manado. Available from: <http://ejournal.unsrat.ac.id/index.php/governance/download/1489/1187>. (2013).
- [31] Ingram, Robert W dan Rinald M. Copeland. "Municipal Accounting Information and Voting Behavior." *The Accounting Review*, Vol. 56. No. 4 published by American Accounting Association. (1981).
- [32] Brusca, Isabel dan Vicente Montesinos. "Are Citizens Significant Users of Government Financial Information? Public Money & Management." *Journal Compilation*, 205-209 <http://dx.doi.org/10.1111/j.1467-302.2006.00526.x> (2006).
- [33] Cassette dan Farvaque. Are elections debt brakes? Evidence from French municipalities. *economics Letters* 122 (2014) 314–316. (2014).
- [34] Balaguer-Coll, M., Brun-Martos, M., Forte, A., & Tortosa-Ausina, E. Local Governments' Re-election and its

- Determinants: New Evidence based on a Bayesian approach. *European Journal of Political Economy*, 39, 94–108. doi:10.1016/j.ejpoleco.2015.04.004. (2015).
- [35] Brender, Adi, Allan Drazen. "Political Budget Cycles in New Versusestablished Democracies" *Journal of Monetary Economics* 52 1271–1295, (2005).
- [36] Setiawan, Doddydan Farah Rizkiah, "Siklus Anggaran Politik Di Masyarakat: Bukti Dari Indonesia," *Jurnal Internasional Bisnis dan Masyarakat*, Vol. 18 No. 3, 533-546 (2017).
- [37] Peltzman, Sam. Voters as Fiscal Conservatives. *The Quarterly Journal of Economics*, Vol. 107, No. 2 (May, 1992), pp. 327-361 Published by: Oxford University Press Stable URL: <http://www.jstor.org/stable/2118475>. (1992).
- [38] Aidt, Toke S, Francisco José Veiga, dan Linda Gonçalves Veiga. "Election Results and Opportunistic Policies: A New Test of the Rational Political Business Cycle Model Metropolitan Boroughs 1902–1937," *Journal of Public Economics* 112 (2014) 53–71. (2014).